

THE DIVINE PLAN AND ITS CHRONOLOGY

AS DEMONSTRATED BY CHERUBS, LIVING ONES, SERAPHIM AND CUBITS!

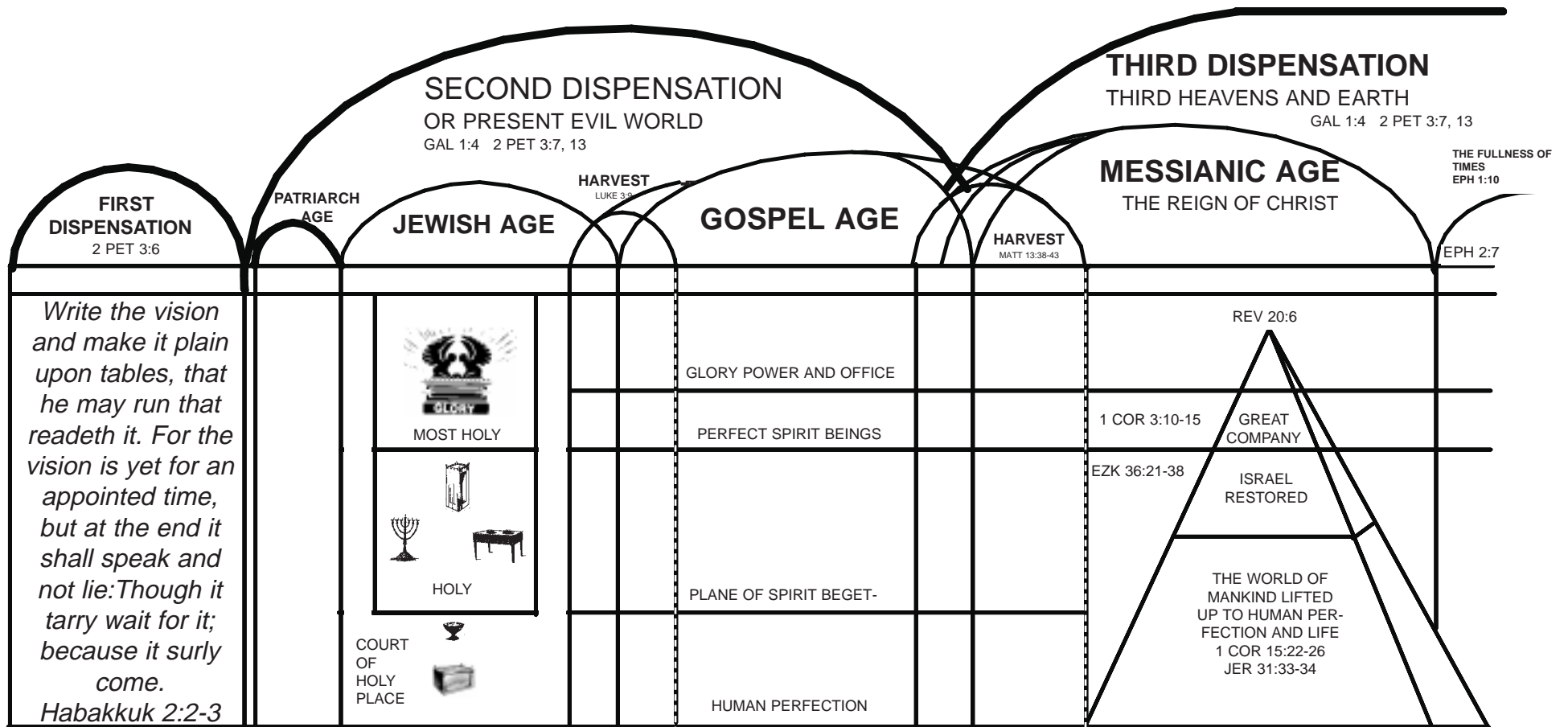

But you, O Daniel, Shut up the words, and seal the book until the time of the end. Then many shall run to and fro and search anxiously [Through the book], and knowledge [of Gods purposes as revealed by his prophets] shall be increased and become great. Daniel 12:4 [The Amplified Old Testament]

THE SPAN OF THE HEAVENS

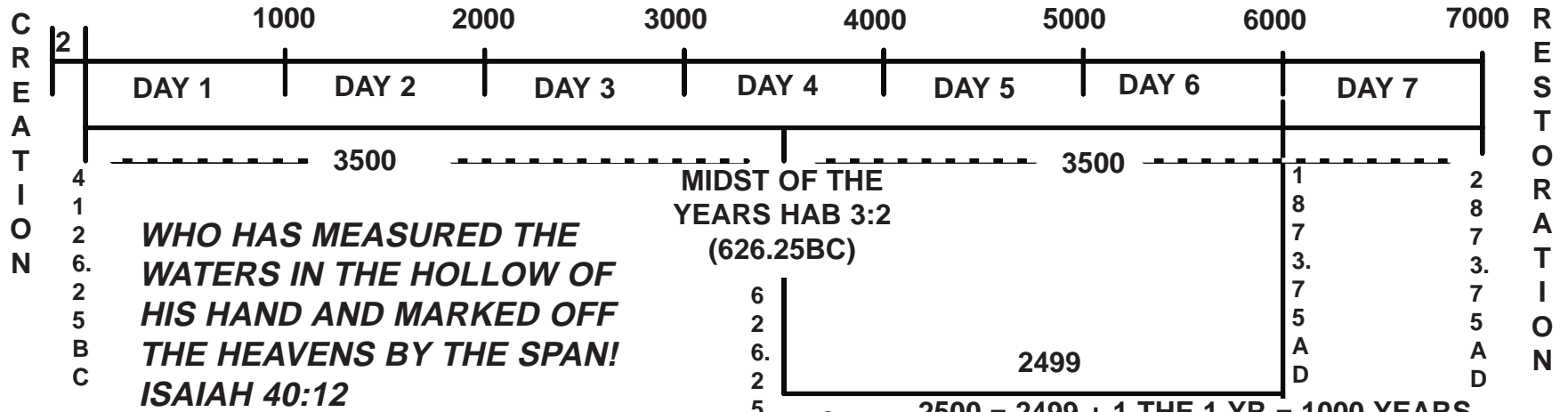

1 DAY WITH THE LORD = 1000 YEARS

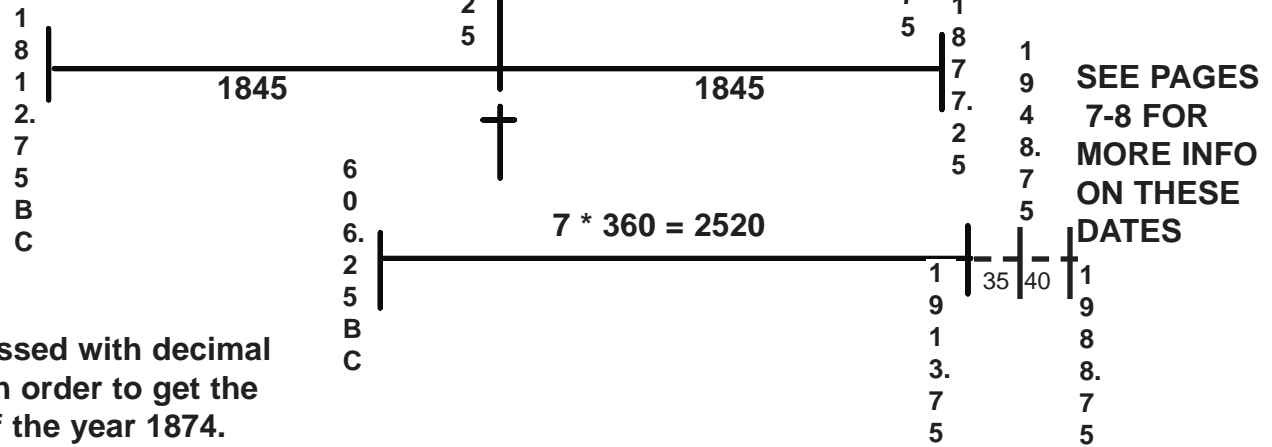
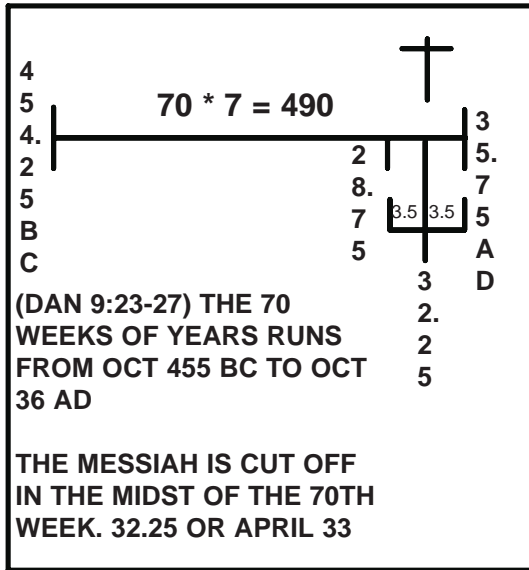

Caution all dates on these charts are expressed with decimal fractions. They must be read with caution in order to get the correct date. For example 1873.75 is Oct. of the year 1874.

THE PURPOSE OF THE BOOK

Although many are trying to do so at this time, predicting the end of the age, is not the intent of this book. The closest that we intend to come to a prediction, is to show that we are very far into an overlap between the gospel age and the millennial age.

We have become convinced that God does not want the exact end time of the gospel age predicted ahead of time, and even though we know more than the early church on this subject, here is Jesus reply on the question of when the kingdom would be returned to Israel. *Acts 1:7 He said to them, "It is not for you to know times or epochs which the Father has fixed by His own authority; (NAU)*

There is no command telling us not to search, and as we will see, there are many other things that we can find out about the times and the seasons. God wants us to be searching and watching for his kingdom.

Matt 24:42 "Therefore be on the alert, for you do not know which day your Lord is coming. (NAU)

We Began the Search With an Existing Scheme of Chronology

Our search for the end time, began with an existing scheme of chronology, that was advocated just before the turn of the twentieth century. This chronology consisted of several different parts, that were each predicting different things.

Some of this chronology originally came from the Adventist, but its now in a modified form from what they had. The chronology had in it, several time lengths, some of which were 1,845, 2,520, 1,260, and 2,500 years. These had been prophetically and historically determined from the bible.

The Chronology Predicted Several Prophetic Events

What we intend to show in this booklet, is that this chronology, which was advocated by the Bible Students, just before 1874 AD, is correct. We will also find that most of the things that were predicted by it, astonishing as it will seem, were true, and in most cases have already happened, or at least started to happen.

The chronology, had predicted a 40 year harvest period at the end of the age, a secret presence of the Lord, and a time of trouble starting in 1914, after the harvest. It also predicted the return of Israel to their land, a judgment of the false church system, and it also shows us that we are entering into the beginning of the time of restoration of all things that Acts tells us about. *Acts 3:20-21) 20 and that He may*

send Jesus, the Christ appointed for you, 21 whom heaven must receive until [the] period of restoration of all things about which God spoke by the mouth of His holy prophets from ancient time.

How these things can be true and what they mean, will be the subject of a special section, which we have placed "after" the discussion of the three different chronology patterns that we will show in this book. That special section, contains a fairly detailed explanation of the chronology we are discussing here, and an explanation of how it relates to God's Divine Plan of the Ages.

While a discussion here of these topics would help in this chronology study, we are afraid that it would be too much for new students, to throw all of that at them first, so we are going to discuss them after the main section of the book. We originally tried to place all of the explanation in this forward, but we wound up with 20 pages of highly detailed information.

So we apologize in advance, because there will be many places in this forward that will say, that a particular topic will be explained in the special section. Our intent here, is to outline briefly what is to be found in the book and then after the reader has seen the Chronology patterns and hopefully seen that there is something to this, he will then put the extra effort into reading all of the explanation involved.

God Has a Plan

The Bible Students advocate that God has a plan, and that he intends to save more than the few who have believed Christ's message during the gospel age. How and why this is going to be, will also be explained in the special section. We are calling the special section, "**Harmonizing God's Plan, and its Chronology**".

The chronology patterns found in this book, will show that the Divine Plan, as the Bible Students see it, is correct and that it is well under way, even though most others don't see it at this time. The patterns, will not only point to the same events that we have mentioned above, but they will have many dates in them that are already historically and biblically determined, and which have already happened. This will help us to see that the prophetically determined dates in the same patterns, are also correct.

Three Different Patterns of Chronology

The three sets of chronology patterns that we will consider in this booklet, will be made up of the same time lengths, that we mentioned above, 1,845, 1,260-2,520, and 2,500. What we are going to see in the book, is that the original Bible Student chronology, was only a small part of the pattern that God has designed into his plan. The original chronology only covered brief historical events, but all

three patterns cover completely the time from the fall in the garden, up to final restoration of mankind, 7,000 years later. God has saved the best wine for last! **The patterns will each have their own theme, the first one will be judgment, the second who has the right to rule, and the third will be love or restoration of mankind back to God's favor.**

An 1845 year Judgment Pattern

The original chronology showed that there was a judgment time and harvest, pointed to by a pair of 1,845 year time periods. The first 1,845 years, went from the death of Jacob, to the death of Christ. The second 1,845 years, went from the death of Christ, to the date of 1878 AD. Just as there was a harvest and testing at the time of Christ, we will find that there was a time of harvest and testing on this end of the age, which began in 1878 AD. We will explain the time of judgment and harvest in the "special section" following the patterns.

What was not known originally, was that there was also a more comprehensive pattern of 1,845's, that reached all the way from the time of Adam, up to the end of the millennial age, exactly 7,000 years later! See page 8. This pattern is a judgment pattern and it shows us several things. **One very important thing, is that the date that Adam failed the original test in the garden, and lost life rights for the entire race, has a corresponding date at the end of the millennium, that shows that all humanity will be granted a new trial for life!**

Two Different Chronological Features Pointed to 1914

The Bible Students, had also recognized that there was a 40 year harvest period, not only in the end of the Jewish age, but that there was another 40 years on this end of the second 1845. Both the end of the 40 year harvest, as well as another set of chronology, which was 2,520 years long, pointed at the year 1914 AD. This chronological theory, predicted that a time of trouble was going to come in Oct 1914, especially upon those who had been involved in the false church state system.

It also predicted that the nation of Israel, would begin to be restored back to their land after that date. All of this came to pass, exactly as history shows, in that 1914 saw the beginning of WW1 in August, and in 1948 the nation of Israel was back in their land! There was a couple of misconceptions about what 1914 represented, which we will save for the discussion in the special section.

The 2520 is Part of a Larger Pattern Regarding Dominion

The 2,520 year chronology, will also be shown to be part of a similar pattern, that again reached from Adam, up to the end of the millennium. See page 18. Mixed into the 2520 year pattern, is a second pattern of 1,260's, that has to do with the rise and fall of the false church system, that we will again explain later. All of the key dates on the 2,520 pattern, are related to civil power and who has the right to it. The false church had taken this power illegally, and used it to oppress the true church during the 1,260 years. In the next age they will be completely disposed and the true church will rule over them.

Rev 3:9 "Behold, I will cause {those} of the synagogue of Satan, who say that they are Jews and are not, but lie— I will make them come and bow down at your feet, and {make them} know that I have loved you.

The 2500 Jubilee is Part of a Larger Restitution Pattern

The 2500 year Jubilee cycle, which was also proclaimed by the original Bible Students, will be discussed, and shown to be part of a much larger pattern, which again stretches from the fall of Adam, to the end of the millennium. See page 31. That pattern will show, that as Adam lost life in the garden, mankind will have life restored by the end of 7000 years from the original fall in the garden.

Cherubim, Living Creatures, and Seraphim

As amazing as all this seems by itself, we will show that the visions of the Cherubim, of Ezekiel chapter 1, and 10, the living creatures of Rev, chapter 4 and 5, and the Seraphim of Isaiah chapter 6, can be graphically seen represented in these three patterns!

Cherubim

The 1845 year pattern, will be seen to contain the description of the vision that Ezekiel saw, in chapters 1 and 10. You will see "graphically represented", 4 Cherubim, with four wings apiece, wheels within wheels, and eyes in the wheels, etc. See page 11-12.

Living Creatures

The 1260, 2520, pattern will be found to contain a "graphically represented" vision of Rev chapters 4 and 5. Again we will see 4 Living Creatures, but with 6 wings this time. The seats of the 24 elders will be there, as well as a central throne. We will see eyes in the living creatures. The 24 elders will also be seen to have golden crowns, as well as harps and white garments, etc. See pages 20-25.

Seraphim

The 2500 year Jubilee pattern, will contain a graphical

vision of four Seraphim, that each have six wings, just as is described in Isaiah chapter 6. See page 32.

The Patterns Are Proof Regarding What God's Divine Plan Is

The chronology patterns will confirm, the "Divine Plan of the ages", as is proclaimed by the Bible Students, then and now. This becomes especially important, when there is so much confusion about what God's plan is. Some even doubt that he has a plan, especially when they listen to the babble of voices, that disagree with each other in the different churches.

God Has Four Perfectly Balanced Attributes

We will see that God's true Divine Plan, has a perfect balance between four different attributes. They are wisdom, justice, love, and power. We will find that these four attributes, are also represented in the chronological patterns. In other words, everything that God does, is governed equally by his attributes. If the plan of God that you have, does not have these four attributes in perfect balance and harmony, you may be assured that you do not have God's plan! That is unfortunately the state of affairs, that exists in many of the churches today.

Try to Read From Front to Back

We recommend that you read from the front of this booklet, without skipping, so that you do not miss some crucial information. After you have read the special section, "Harmonizing God's Plan, and its Chronology", if you go through the patterns a second time, they will most likely make better sense to you.

We have saved a lot of the other explanation for later, since the main theme of the book is in regard to the chronology patterns, and the visions that we find in them.

We Will Try to Explain Everything in the Special Section

We originally had a lot of other material in the forward, but we became concerned that the reader would become bogged down in that, and never get to the heart of the book. For that reason we split off the explanation of the Bible Student chronology and God's plan, into the other section. We include a great deal of material in there, that explains the Divine Plan of the ages and what God has been doing. The few problems that occurred with what was predicted by the chronology are explained in that section. We even explain about the great falling away, and how it came about, and what God has done and is going to do about it.

The Lessons Should be More Clear a

Second Time Through

When dealing with material that is unknown to the reader, its hard to determine what they know or don't know. So if any of this is obscure and hard to understand, its most likely is our fault and we would appreciate hearing what part is not understood, so we can try to clarify it.

As you look at the patterns that follow this, you should be aware that a lot of what you don't understand or aren't familiar with, will be explained in the special section. After you read that and look at the patterns again, the lessons that they are teaching, should be more clear the second time through. We decided against placing the special explanations first, because of the danger that many of the readers would give up, without seeing the incredible evidence that the chronology patterns will show!

If you wind up with to many questions to understand what is going on, there is nothing to stop you from going to that section on page 38, reading it and then coming back. We recommend that you try it from front to back first.

We Also Cover All the Rest of the Cubits in the Bible

After the special section with the explanation in it, there is a lot more material, regarding the use of cubits in the bible. We will see the "same" manner of use, no matter if its in the wilderness tabernacle, or in Ezekiel's temple. We have tried to include all of the places that the cubits are mentioned in the bible and show that all the interpretations regarding them, point to the Divine Plan of the Ages.

There are a lot of other interesting things in that section, that may be of interest to some readers. As far as the temples and objects, that are found there, we have tried to diagram them as accurately as we can, but we realize that there may be other opinions on some items. We would be interested in any other opinions, regarding them.

There Will be a Section On the Great Pyramid.

Again the numbers that we will see there, will match the chronology that we are discussing in the rest of the book. The dates that will be pointed to, are again the same as the ones that we are discussing in this book. The symbolism represented in the passages, will show the decline and fall of mankind, and the uplift of the gospel age that God has opened up through Christ. The salvation that will come to the rest of the world in the kingdom is also pictured there.

A Section that Explains How the 1845 year pattern Was Constructed

In this section we will attempted to explain the theory behind

PAGE 4

the 1845 year pattern. We will go through the thought behind the pattern, step by step and show how it was developed. At this time, we have not done that for the 1260-2520 pattern. The 2500 jubilee circles come from the location of the tabernacle fence posts, so there is not much to explain there.

A Warning About Modifying the Chronology and Not Keeping the Same Total Count of the Years

Here we show how both the patterns and the Bible Student Chronology are disrupted, if you take out any amount of time, and don't put it back within a narrow range of years.

Since we originally wrote this section, we have found a possible modification of taking out 19 years in that area, and then putting it back in the time of Joshua. Doing it that way does not cause any of the problems we are warning about, in this section.

We have left the warning section, so that you can see that changing the "total" count of the years is fatal to the chronology. As you look at the examples and you see what happens, it will become obvious that since the original patterns work, they are either one big coincidence or else God designed them! The possible fix for the 19 years is explained on pages 16-17, just before the section regarding the 1260-2520 pattern.

We Recommend Reading, "The Studies in the Scriptures".

Since most of this booklet is related to bible chronology and the Divine Plan of the Ages, we also recommend reading and having a knowledge of at least volumes 1-3, of "Studies in the Scriptures". There are actually six volumes and they are all good, with many challenging thoughts. There is even a seventh book on the tabernacle and the lessons that it teaches us. The address regarding how to get these books, is given in the special section on page 38.

You may read this book first, but you will gain a better understanding of it, if you read the other volumes, and then come back a second time and read this book again. Even though the books are over 100 years old, you will find them amazing, especially since all of these events are being written about in advance. You need to keep in mind the age and time they were written, since there have been major changes in the world since that time. Nevertheless what you will find there is very accurate and thought provoking and still applies to today.

You May Reproduce this Work

You may copy or reproduce this book, as long as it is done without any profit involved in it, and the entire book is kept intact. In other words you may ask for duplication fees, but

no profit should be made on this. God has supplied us with his blessings free of charge and we should do the same for others.

Isa 55:1-3) 1 "Ho! Every one who thirsts, come to the waters; and you who have no money come, buy and eat. Come, buy wine and milk without money and without cost. 2 "Why do you spend money for what is not bread, and your wages for what does not satisfy? Listen carefully to me, and eat what is good, and delight yourself in abundance. 3 "Incline your ear and come to me. Listen, that you may live; and I will make an everlasting covenant with you, {according to} the faithful mercies shown to David. (NAU)

Partial quotations may be made for the purpose of enhancing knowledge of God's plan, as long as reference is made to the book, and where to read its entire message. The reason we ask this, is that we do not want something quoted out of context.

A Biblical Timeline of the 7000 Years

We also intend to include a timeline of the 7000 years as a separate supplement to this booklet. It will have both the traditional Bible Student timeline, as well as the modified one that we think will fix the 19-20 year question.

Any replies or comments, regarding this work may be directed to my E-Mail address. We will try to answer any reasonable question, unless the volume of mail is too large! If its a comment about a needed improvement, we will incorporate it in a future edition.

A Word of Warning

If you are viewing this on the internet, some of the pages have a lot of graphics on them, so they may load slowly. Please be patient, we think it will be worth it. **For those who wish to study this off line, we intend to make a complete .pdf file available for download.**

pmezera@inwave.com

Paul Mezera 10/8/98

TABLE OF CONTENTS

PAGE 5

1. DIVINE PLAN COVER PAGE -----	(A)
2. SPAN OF THE HEAVENS TIME LINE CHART -----	(B)
3. STATEMENT OF PURPOSE -----	PAGE 1-4
4. TABLE OF CONTENTS -----	PAGE 5
5. TABLE OF BC AND AD DATES -----	PAGE 6
6. PICTURE OF EZEKIEL'S VISION ? -----	PAGE 7
7. CHRONOLOGY DEALING WITH THE 1845 PARALLELS	
(A) 1845 YR CIRCLES -----	PAGES 8, 9
(B) WINGS AND WHEELS WITHIN WHEELS -----	PAGE 10
(C) THE 4 CHERUBS WITH 4 WINGS -----	PAGE 11
(D) EYES AND THE FORM OF A MAN'S HANDS -----	PAGE 12
(E) MORE ON THE WHEELS AND CREATURES -----	PAGES 13-14
(F) PARALLEL OF THE JEWISH AND GOSPEL HARVEST -----	PAGE 15
8. FIXING A 19 YEAR PROBLEM?	
(A) TAKING 19 YEARS OUT AND PUTTING 19 YEARS BACK WITH JOSHUA-----	PAGES 16-17
9. CHRONOLOGY DEALING WITH THE 1260 AND THE 2520 YRS	
(A) 1260 AND 2520 CIRCLES AND EXPLANATION OF DATES -----	PAGE 18-19
(B) 24 ELDERS, SEATS AND A THRONE -----	PAGE 20
(C) 4 LIVING CREATURES SEPARATED OUT -----	PAGE 21
(D) GOLDEN CROWNS, WHITE GARMENTS, AND 7 LAMPS-----	PAGE 22
(E) EYES AND GOLDEN BOWLS FULL OF INCENSE -----	PAGE 23
(D) 24 ELDERS AND HARPS -----	PAGE 24
(F) THE EMERALD RAINBOW ABOUT THE THRONE -----	PAGE 25-29
8. PROPHETIC 25 INCH CUBIT AT AN INCH PER YEAR.	
(A) TABERNACLE CHRONOLOGY -----	PAGES 30
(B) 2500 CIRCLES AND LOVE -----	PAGES 31
(C) 4 SERAPHIM OF ISAIAH 6 -----	PAGE 32
(D) MIDST OF THE YEARS AND THE ARK OF THE COVENANT-----	PAGE 33
(E) TABERNACLE FURNITURE -----	PAGE 34
(F) WILDERNESS TABERNACLE -----	PAGE 35
(G) A SYMMETRICAL AND COMPOSITE CHART OF THE 1845, 1260, 2520 AND 2500 YEAR CIRCLES -----	PAGES 36-37
9. DISCUSSING GOD'S PLAN AND ITS CHRONOLOGY EXPECTATIONS-----	PAGES 38-55
(H) SOLOMON'S TEMPLE AND PARTS -----	PAGES 56-59
(I) EZEKIEL'S TEMPLE AND PARTS -----	PAGES 60- 62
(J) OTHER CUBIT APPLICATIONS IN THE BIBLE -----	PAGES 63-67
10. THE PYRAMID AND THE 25 INCH CUBIT AT AN INCH PER YR -----	PAGE 68-73
11. A FINAL WORD -----	PAGE 74- 75
12. EXPLANATION OF THE SYMMETRICAL PATTERNS	
(A) HOW THE 1845 CHART IS CONSTRUCTED -----	PAGE 76-79
13. EXAMPLES OF PROBLEMS THAT WOULD OCCUR IF WE REMOVED 20 YEARS WITHOUT PUTTING IT BACK	
(A) SOME PROBLEMS INVOLVED IN CHANGING THE CHRONOLOGY -----	PAGE 80-85

Due to some confusion as to how to read the decimal dates on these charts, we have included this page, which has most of the dates that you will find in this booklet. The decimal system that is used on these charts is easy to use when you are adding and subtracting dates from each other, especially with a calculator, but it can be confusing as to how the dates should be read. This page shows the exact decimal date and then the correct way to read it.

THE DATE OF CREATION 4128.25 BC IS OCT OF 4129 BC.	MINISTRY OF OUR LORD 28.75 AD OR OCT 29 AD
THE DATE OF THE FALL IS 4126.25 BC OR OCT OF 4127 BC	THE CRUCIFIXION 32.25 AD IS APRIL OF 33 AD
THE END OF ADAMS FIRST DAY 3126.25 BC IS OCT OF 3127 BC	END OF JEWISH FAVOR 35.75 AD OR OCT 36 AD
END OF THE FLOOD 2471.25 BC IS OCT OF 2472	START OF 1260 538.75 AD OR OCT 539 AD
JACOBS DEATH 1812.75 BC IS APRIL OF 1813 BC	END OF 1260 1798.75 AD OR OCT 1799
JAIR TYPE OF CHRIST 1251.25 BC IS OCT OF 1252 BC	END OF 1290 1828.75 AD OR OCT 1829 AD
MIDST OF THE YEARS 626.25 BC IS OCT OF 627 BC	END OF 2300 DAYS 1845.75 AD OR OCT 1846 AD
THE START OF THE JUBILEE 625.25 BC IS OCT OF 626 BC	7 TH DAY END, 1335, JUBILEE 1873.75 AD OR OCT 1874
START 70 YRS DES AND 2520 606.25 BC IS OCT 607 BC	END 1845 PARALLEL 1877.25 AD OR APRIL 1878 AD
REBUILDING OF THE TEMPLE 454.25 BC IS OCT OF 455 BC	END 2520 , 40 YR HARVEST 1913.75 AD OR OCT 1914 AD
BIRTH OF CHRIST 1.25 BC IS OCT OF 2 BC	MANKIND RESTORED 2873.75 AD OR OCT 2874 AD

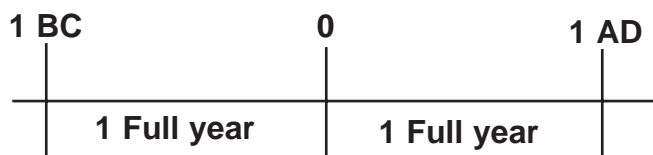

Zero is not a year but is only the dividing point between 1 BC and 1 AD! 1 BC and 1 AD are each 1 full year in length

Bible version abbreviations used in this booklet are as follows

KJV-King James version. NIV-New International Version TLB-The Living Bible NAS-New American Standard
ASV-American Standard Version RSV-Revised Standard Version



EZEKIEL'S VISION ?

No one knows, what the actual vision that Ezekiel saw, looked like. This is an artistic, rendering of that vision? What we are going to see in the pages that follow this one, will require a little more imagination than the vision we see here. What we will find in the booklet, will be graphically represented by, lines, curves, shapes and shading, but which you will find, will match the scriptural description exactly!

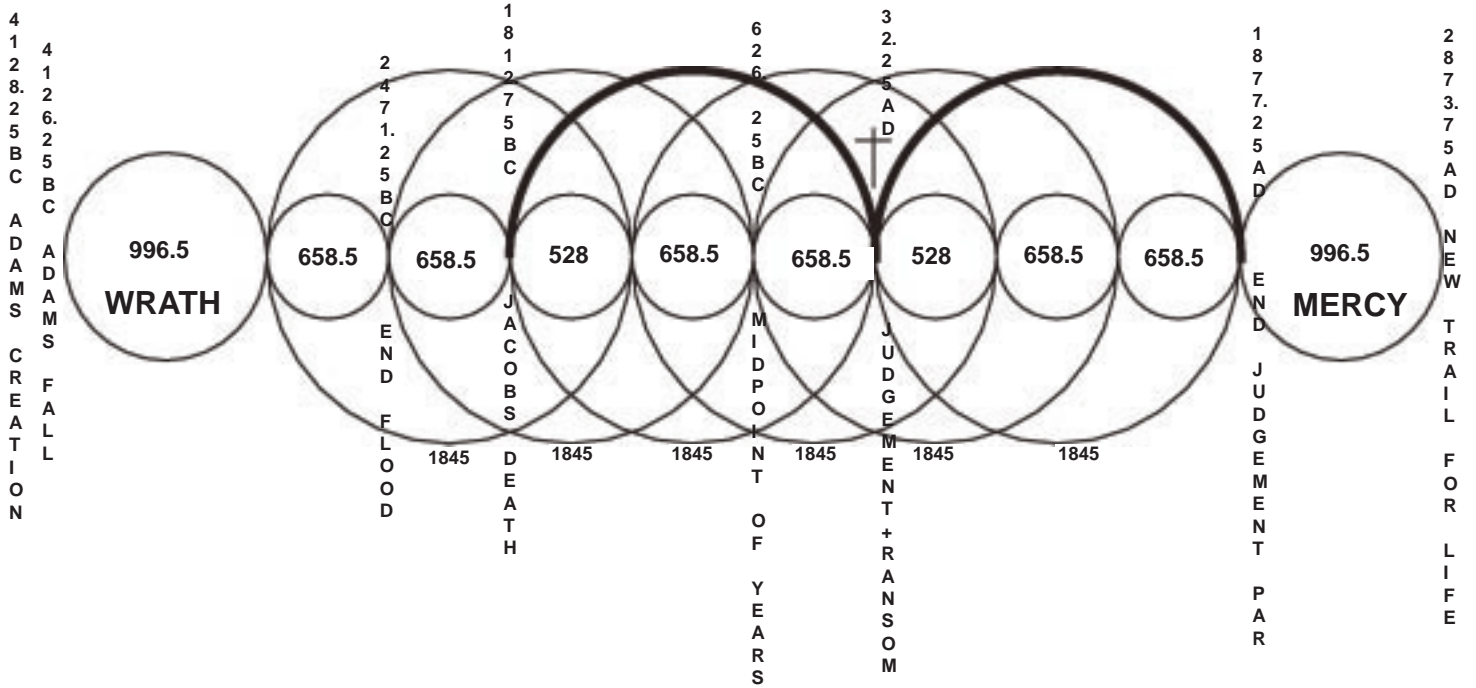

JUSTICE OR JUDGMENT

Original 1845 Parallel's

The two darker, 1845 year arcs above, (1812.75 BC-32.25 AD and 32.25 AD-1877.25 AD), are from the 2nd volume, Studies in the Scriptures "The Time is at hand, chapter 7". These parallel arcs, show us that what happened at the first advent, with the judgment and fall of the Jewish house, has happened again, on this end of the age, with the judgment and fall of the spiritual house. See page 15. For an explanation of how this chart was derived, see pages 76-79.

More 1845's

The circular repeating pattern that we see above, is an amplification of the original 1845 year chronology. All of the other large circles are also 1845 years, and they form a repeating pattern, that starts 3.5 years, before the end of the first Adam's, 1000 year day. The pattern ends, 3.5 years after the beginning of the 7th. 1000 year day, (the second Adams day or Christ's day).

Seven Important Dates

The pattern above, intersects a total of 7 important Biblical dates, that have to do with testing and judgment. (1) The end of the flood, (2) Jacob's death, (3) the midpoint of the years, (4) the crucifixion and end of Jewish favor and (5) the end of the nominal double (see volume 2 page 219 Studies in the Scriptures and page 15 in this booklet). Also included are (6) the fall of Adam and loss of life in the garden and (7) the new trial for life 7000 years later.

Midst of the Years Symmetry

The above pattern, is symmetrical about the midst of the year 626.25 BC. The center point of the years, is referred to in Hab 3:2, (King James version), and is a date that is 3500 years after the fall of Adam, and 3500 before the restoration of mankind, making a total of 7000 years for God's plan.

If we were to fold this pattern exactly in the middle, it would be seen to be symmetrical about this midpoint, with the corresponding circles on one half, falling exactly on top of the circles on the other half. If an intersection on one side of the chart does not have a date that is important Biblically, the other symmetrical side will.

A New Trial for Life

The fall in the garden, and the restoration, are the only two dates, that would fall on top of each other. **This makes sense, in that the last date at the end of the 7000 years, is showing us that what Adam lost in the garden, (life), will be restored, with all mankind getting a new trial or testing, before justice.** Christ will be the judge in the next age, and Adam and the whole race will get this new testing, because of the ransom price he paid!

Those who take this test, will be much more likely to pass it, than Adam and Eve. The reason, is that they will have had experience with sin and death, while we know that Adam and Eve did not. The entire intent of God's plan, is to restore everyone back to a condition, where they will be able to pass this test, Rev 20:7-10. The wrath that mankind has been under, since the fall in the garden, will be removed in the time of mercy, (by end of millennial age)! The creation date, is not part of this pattern, since Adam didn't need salvation until he fell. We have included it, to show that he more than likely spent two years in the garden before he fell.

Revive Thy Work in the Midst of the Years

As we see above, Habakkuk had asked that God revive his work in the "midst" of the years. Some question this meaning, since not all translations use the word midst or middle. The word used here, (midst), as defined in Strong's concordance, is word #7130 and it does mean "center or middle".

As was asked in Habakkuk's prayer, even though God sentenced

O LORD REVIVE THY WORK IN THE MIDST OF THE YEARS, IN THE MIDST OF THE YEARS MAKE IT KNOWN, IN WRATH REMEMBER MERCY:

HABAKKUK 3:2 SEE ALSO ROMANS 5:9, 11:32 ISAIAH 49:10, 13, 54:8, 10 EZEK 39:25 MICAH 7:18, 20

Adam to die, “**wrath**”, he will by the end of the 7000 years, show “**mercy**”, and restore all who are willing, back to full human life rights. On the previous page, the fall in the garden, is marked by the word “**wrath**”, and the restoration during the millennium, by the word “**mercy**”. See Edgar’s pyramid book, volume 2, page 123, where he uses this same terminology.

Date of the Flood Problem

Of the seven dates, we to begin with had some trouble with the date of the flood. That date, as originally given in the 2nd volume, “studies in the scriptures”, page 43, missed its intersection with the circles, by 1 year. At the bottom of the table, presented on that page, it correctly stated that **Noah was 600 years old, when the flood came upon the earth** (Gen 7:6). What we found was that when the table in the second volume. is added up, **the total given, should have been to the start of the flood, and not to the end**. The flood was 1 yr. in duration, and the total to the end of the flood, was 601 yr., (Gen 8:13). **The total count of years, is not changed**, because we are still adding the same numbers together, but the date of **the flood, is shifted 1 year**, and **that circle now intersects the end of the flood exactly!**

Theme of Judgement

The main theme, of this pattern, is judgment and justice. **God has laws and rules, and he expects his creation to obey them. Since they did not, justice punished them in wrath**, (4126.25 BC). God’s Love provided Christ as the ransom price, (32.25 AD on the previous page). **The ransom, mercy, redeemed Adam, and the entire human race, back from the penalty justice imposed, death.**

The **first** judgment date, in the above pattern, is the fall in the garden. Adam and Eve, were instructed not to eat of the fruit of the tree, of knowledge of good and evil, or they would die. Unfortunately, they did eat, after being tempted by the serpent and both them, and the entire race, were plunged into sin and death.

At the **second** judgment date of the flood, we find that the entire race was corrupt. We are not sure, but the angels may have attempted to restore mankind, by inbreeding with them. Their effort failed, because God saw that the half breeds were evil, and not part of his plan, and for that reason, he destroyed them in the flood, (Gen 6:2, 5, 11-13). Its not clear if the angels original intent was good, or if they did this under the instruction of Satan, who was trying to put himself above God. The lesson again, is that we need to do things Gods way, and not just our way, or we will fail.

The **third** testing, was when Abraham, Isaac, and Jacob, passed their respective tests of faith. After Jacob died, having passed his test, God began to deal only with the nation of Israel. As we remember, the promise to Abraham, had been that, “*through thee and thy seed, all the families of the earth would be blessed*”, Gen 22:15-18.

That promise included a heavenly seed, (like the stars), and an earthly seed, (like the sand of the sea shore). *Gen 22:17 indeed I will greatly bless you, and I will greatly multiply your seed as the stars of the heavens and as the sand which is on the seashore; and your seed shall possess the gate of their enemies.*

The promise, passed through Abraham’s offspring, until it resided with the nation of Israel. Israel was to be the blessing nation, through whom the seed, the Messiah was to come. God made a law covenant with them, which they were not able to keep, because of their human imperfections. The scriptures tells us, that the law was given, to show us what sin was, and to point the way to the promised seed, which was Christ, (Gal 3:19-25).

The **fourth** date is the midst of the years, which is 3500 years from the fall! Everything in this pattern, as well as the two others, that you will find in this book later, revolves around this center point. **God is making his plan known, “through the midst of the years”**, just as Habakkuk had asked.

At the time of the **fifth** date, the Jewish house was tested, and they failed. Most Jews did not accept Christ, at the end of the Jewish age, and for that reason, the Gentiles were able to become replacements, by accepting Christ, (Romans 11:11-12). Spiritual Israel, replaced earthly Israel, in the gospel age. Christ did prove faithful, in his testing at that time, and for that reason, the gospel age was able to begin.

Harvest and the Wheat and Tares

At the **sixth** date, the final judgment or testing of the gospel age church, began in 1878, at the end of the 1845 yr parallel, and this testing continues, until the church is complete. This is the harvest, at the end of the age, and the separating of the wheat and the tares.

New Trial for Life

The **seventh** and final judgment, that will occur, is at the end of the seventh, 1000 yr. day. That is when all mankind will be perfect again, and completely released from the first failure in the garden. They will be able to stand trial for life again, and with the experience they have gained with sin and death, they should have no trouble passing the new test, (Rev 20:7-9). This judgment, will not depend on what someone else does, but each individual, will pass or fail on their own merit

Jer 31:29-30) 29 "In those days they will not say again, "The fathers have eaten sour grapes, and the children's teeth are set on edge."

30 "But everyone will die for his own iniquity; each man who eats the sour grapes, his teeth will be set on edge. (NAU)

Main Lesson of Pattern

The main theme, of the 1845 pattern, is “**judgment**” or “**testing**”, and we see that God’s law or justice, is the standard by which all judgment or testing is done. God love has now provided, through Christ, the means by which all can be saved and pass the final test at

Ezek 1:4-23) 4 I looked, and I saw a windstorm coming out of the north-- an immense cloud with flashing lightning and surrounded by brilliant light. The center of the fire looked like glowing metal,

5 and in the fire was what looked like **four living creatures**. In appearance their form was that of a man,

6 but **each of them had four faces and four wings**.

7 Their legs were straight; their feet were like those of a calf and gleamed like burnished bronze.

8 **Under their wings on their four sides they had the hands of a man. All four of them had faces and wings,**

9 and **their wings touched one another**. Each one went straight ahead; they did not turn as they moved.

10 Their faces looked like this: Each of the four had **the face of a man**, and on the right side each had **the face of a lion**, and on the left **the face of an ox**; each also had **the face of an eagle**.

11 Such were their faces. Their wings were spread out upward; each had two wings, one touching the wing of another creature on either side, and two wings covering its body.

12 Each one went straight ahead. Wherever the spirit would go, they would go, without turning as they went.

13 The appearance of the living creatures was like burning coals of fire or like torches. Fire moved back and forth among the creatures; it was bright, and lightning flashed out of it.

14 The creatures sped back and forth like flashes of lightning.

15 As I looked at the living creatures, **I saw a wheel on the ground beside each creature with its four faces.**

16 This was **the appearance and structure of the wheels**: They sparkled like chrysolite, and **all four looked alike. Each appeared to be made like a wheel intersecting a wheel.**

17 As they moved, they would go in any one of the four directions the creatures faced; the wheels did not turn about as the creatures went.

18 Their rims were high and awesome, and **all four rims were full of eyes all around.**

19 **When the living creatures moved, the wheels beside them moved; and when the living creatures rose from the ground, the wheels also rose.**

20 Wherever the spirit would go, they would go, and **the wheels would rise along with them**, because the spirit of the living creatures was in the wheels.

21 When the creatures moved, they also moved; when the creatures stood still, they also stood still; and when the creatures rose from the ground, the wheels rose along with them, because the spirit of the living creatures was in the wheels.

22 Spread out above the heads of the living creatures was what looked like an expanse, sparkling like ice, and awesome.

23 **Under the expanse their wings were stretched out one toward the other**, and each had two wings covering its body. (NIV)

4 Living Creatures in the Circles of Chronology

As amazing as the chronology patterns are by themselves, there is another aspect to them, which is so wonderful, that there is no doubt that they are from God. If you examine the drawing on the opposite page, you will find the pattern of 1845 yr circles, repeated 4 times, with different portions shaded in. By shading in different portions of the circles, it's possible to see a graphical representation of Ezekiel's vision, of 4 living creatures or Cherubs. This graphical representation, is not what Ezekiel saw, since he saw the vision of actual living creatures, but we will find that it matches his description exactly, as far as the correct number of Cherubs, wings, wheels within wheels, eyes in the wheels and etc.

A Pair of Wings

If you examine pattern number 1, you will see that the upper half of the shaded in portion, looks like the pair of wings on the right. We also find a second pair of wings, located upside down, under the first pair, making 4 wings. That matches Ezekiel's description, in that each living creature, had four wings! Ez 1:6, 10:21

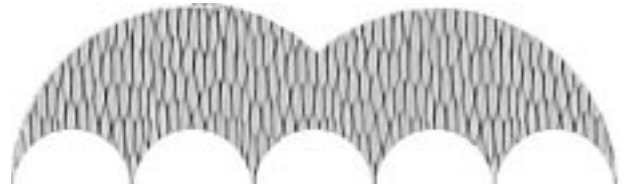

A Pair of Wings

A Wheel Within a Wheel

In Ezekiel 1:15, it says that there was a wheel within a wheel, beside each living creature, and this is what we see represented on the next page. Each shaded in living creature, has 4 wings and a centrally located, wheel within a wheel, like the one to the right on this page.

4 Living Creatures

According to Ezekiel, there were only 4 living creatures, and if you look at the 4 shaded in portions on the next page, you will find 4, and only 4, living creatures. As each one is shaded in, the next one begins 1 space to the right, until we reach the 4th Cherub. At the fourth Cherub, there are no more spaces to the right, so there is room for only four Cherubs and no more!

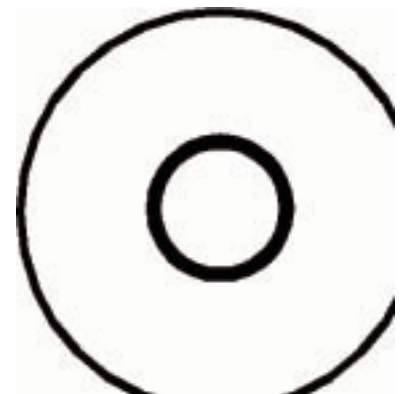

WHEEL WITHIN A WHEEL

Touching or Overlapping Wings

If we were to put all four Cherubs on top of each other, on one line, we would see that the wings would be touching and overlapping each other just as is described in Ezekiel 1:9.

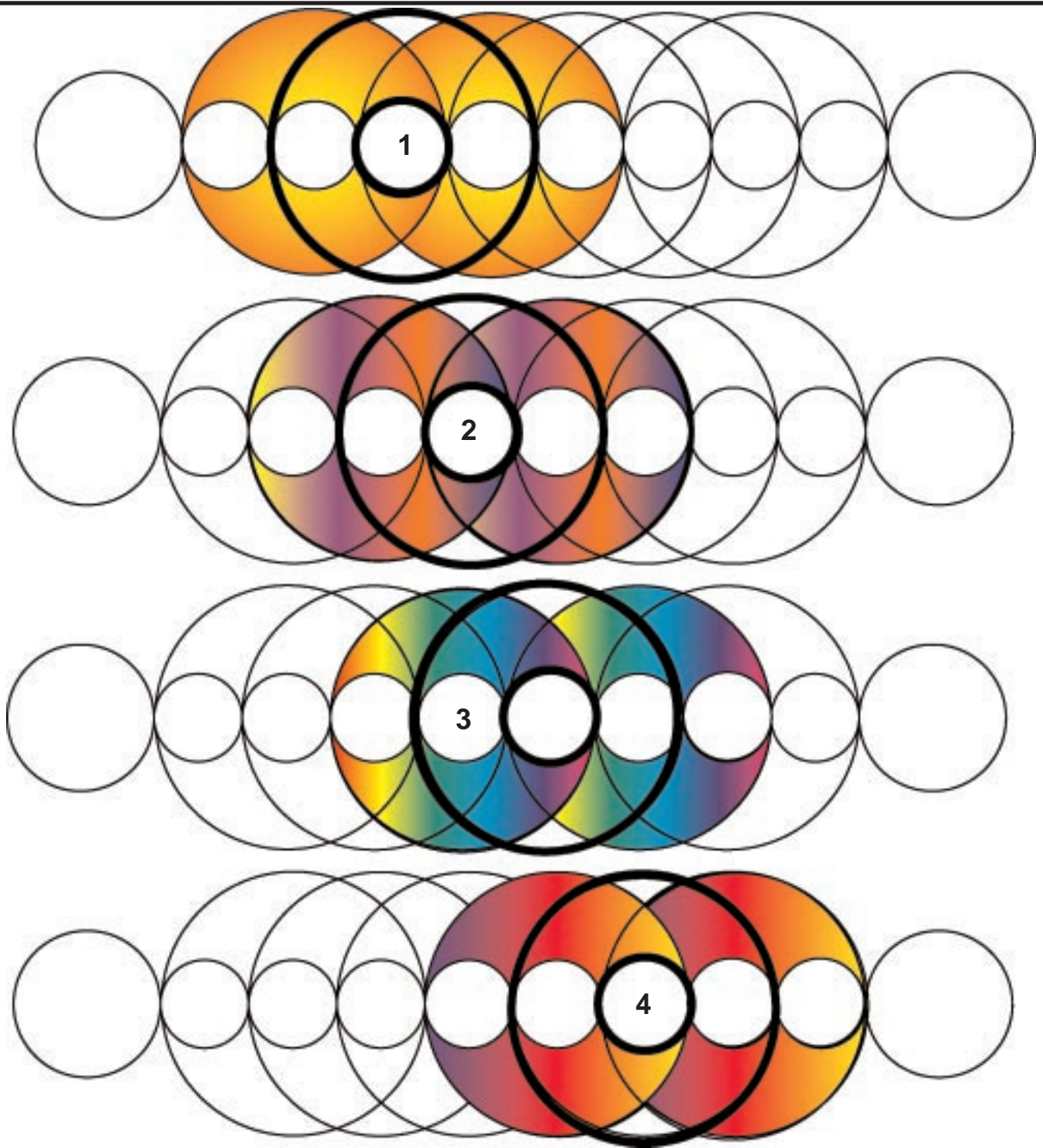

Four living Creatures, had 4 wings, 4 Faces and a Wheel Within a Wheel

[Ezk 1:6, 9, 10, 14-20 and Ezk 10:9-14, 21].

In chapter one, the faces are listed as the face of a Man and a Lion on the right, and as an Ox and an Eagle, on the left. In chapter 10, the description is different, in that it says the first face was a Cherub, the second a Man, the third a Lion, and the fourth an Eagle. Note that they are the same

faces as chapter 1, except that in chapter 10, the Ox becomes a Cherub! This change shows a further progression in Gods plan, after which Jesus has paid the ransom price, and has become a Cherub, (new creature).

These diagrams are two dimensional, so we can't see it, but its likely that the Cherubs were arranged in a circular pattern, like a torus, (doughnut shape), about the center or throne. This is also true of the two other charts, (1260-2520, and the 2500), found later in the booklet.

AND THEIR RINGS WERE FULL OF EYES, ROUND ABOUT THEM, FOUR, EZK 1:18, 10:12

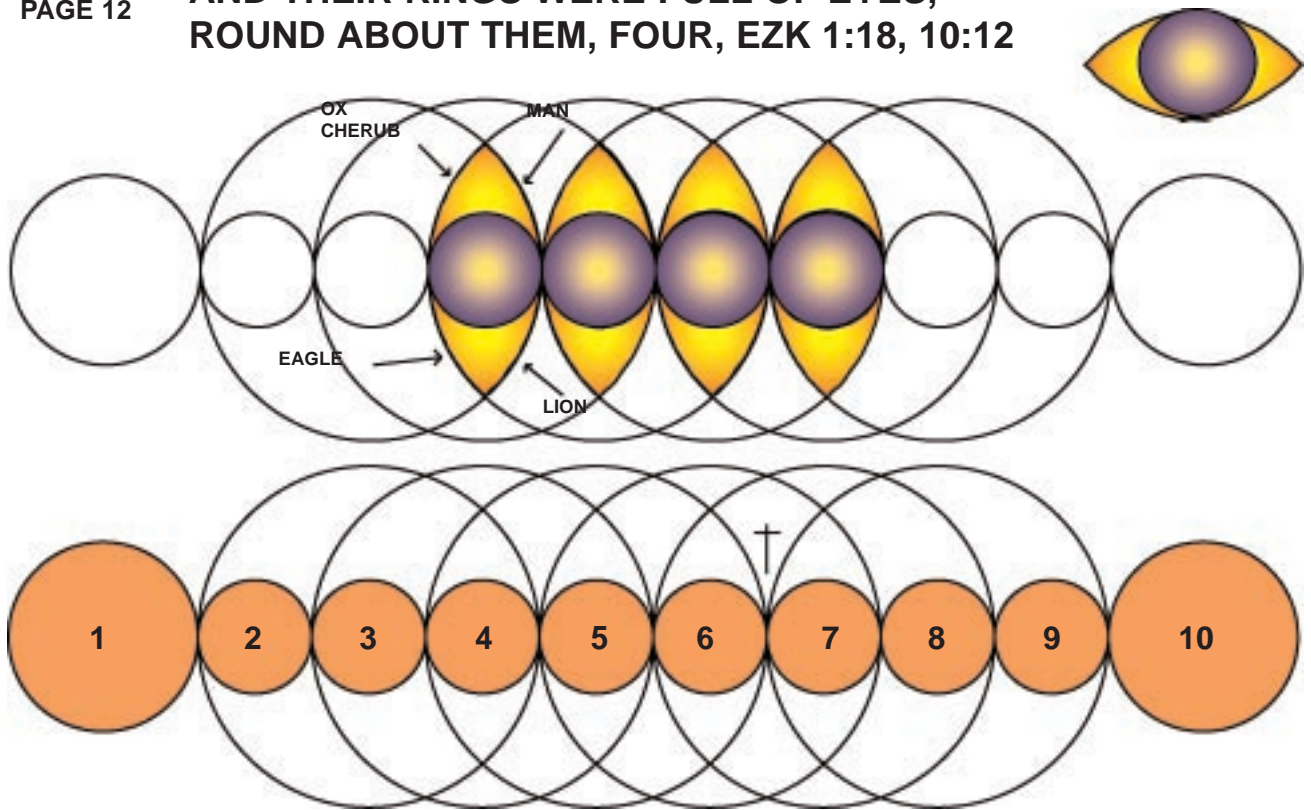

AND THERE APPEARED IN THE CHERUBIM'S, THE "FORM" OF A MAN'S HAND, UNDER THE WINGS, EZK 10:8

The Eyes in the Wheels

The eyes above, are formed within the overlapping chronological circles.

The "Locations" of the Four Faces

The 4 curved segments, that make up the outer part of each eyeball, fit the description of the locations of the 4 faces, as given by Ezekiel. We have placed arrows, pointing to the faces on the one on the left, to help show the locations. We don't actually see the faces, but only the locations where they would be. We have two segments, representing faces on the left, and two on the right. The faces are centrally located, in respect to each Cherub.

Coals of Fire or Ransom on the Altar

The ransom that was paid by Christ, is represented by the coals of fire, as described in Ezk 10:2,6-8. The location of the fire on the altar, 32.25 or April of 33 AD, between the Cherubs, is marked by the cross above, between circles 6 and 7.

The "Form" of a Man's Hands

When the Cherub took the coals of fire, and gave them to the one clothed in linen, the form of a man's hands appeared under the wings. Notice, that it says the "form" of a man's hands, and not a man's hands, (Ezk 10: 8). **What we see here, are the fingers, as if viewed from the ends, with them pointing at you**, and they are numbered 1-10, in the drawing above. The hands, or actually the round fingers, are formed under the wings, as described in Ez 1:8, 10:8.

This helps to explain Ezk 1:8, in that it says under the wings, on their 4 sides, were formed human hands. The bottoms of the 4 sets of wings, actually form the outline of finger holes.

An Open Hand

The word "hand", used in both chapters, doesn't appear to fit the finger holes that are described, until we look up its meaning. Its Strong's word # 3027, a hand [the open one {indicating power, means, etc}]. This is different from word # 3709, which means a closed hand.

We suggest that the 10 finger holes, are in symbol the open hands of Christ, as seen from an end view. There is no doubt, that he has the power and means to carry out, uphold and support Gods plan, especially since he paid the ransom, Rev 5:5! On the inside cover of this booklet, we quote Isaiah 40:2, in regards to the heavens being marked off by the span. If a span is the width of a hand, the heavens are marked off with two spans, 3500 yrs apiece, just like above.

The Marriage Betrothal

With Christ facing us, and the fingers being held out towards us, the ring finger is circle 7, which corresponds to where the church began, at the first advent, 32.25 AD! Remember, there was a binding betrothal or engagement first, and then the Jewish wedding would take place, sometimes up to a year later, (end of the gospel age). This allows God time to prove the heart and faithfulness, of all the parties involved in the marriage of the Lamb, Rev 19:7-9!

Wheels and Creatures as a Unit

The New English translation says: *{when the living creatures moved, the wheels moved beside them; when the creatures rose from the ground, the wheels rose together with them, for the spirit of the living creatures was in the wheels. When one moved, the other moved; when the one halted the other halted; when the creatures rose from the ground, the wheels rose together with them for the spirit of the creatures was in the wheels}* Ez 10:16-18.

Bible Chronology is a Unit Also

This description, seems to show that the Cherubs and the wheels, were all locked together as a unit, and that one Cherub couldn't move, without the others moving. This is a fitting description, of how the chronology of the Bible, is locked together. The traditional chronology of 1845, 1260, 2520, and 2500, can't be lengthened or shortened by a single year, or even a tenth of a year, without disrupting the harmony of the repeating pattern.

The Wings of the Living Creatures are Overlapped, Just as Described

If we were to examine all 4 sets of Cherubs, together as a unit, we would see that all of the wings are joined together, or are overlapping each other, as described in Ezekiel 1:9,11.

A New Trial For Life Confirmed

The repeating pattern of 1845 circles, helps confirm that the divine plan of the ages is correct, and that all of mankind, will have the chance to be restored to perfection, and to stand trial again, under favorable conditions at the end of the 7000 years. It also shows, that the event that made this possible, was the ransom paid by our Lord, (32.25 AD).

The little season, Rev 20:7-10, more than likely starts immediately after 2873.75, but whether it will be 2, 3.5, 7, 40, or more years in length, is not shown! The question of the length of the little season, and if it has different phases to it, like the gospel age harvest, is not shown by these patterns!

Tree of Life Forbidden

We see in Gen. 3:24, that God had placed Cherubs, and a flaming sword, to guard the way to the tree of life. *(Gen 3:23-24) 23 Therefore the LORD God sent him forth from the garden of Eden, to till the ground from whence he was taken. 24 So he drove out the man; and he placed at the east of the garden of Eden Cherubims, and a flaming sword which turned every way, to keep the way of the tree of life. (KJV)*

This is very interesting, as we see here that one of the things the Cherubs can represent, is chronology. We think that this shows that God intended, that there would be a fixed time,

before mankind could again approach the tree of life. We see that access to the tree of life is eventually restored in Rev. *(Rev 22:1-3) 1 And he shewed me a pure river of water of life, clear as crystal, proceeding out of the throne of God and of the Lamb. 2 In the midst of the street of it, and on either side of the river, was there the tree of life, which bare twelve manner of fruits, and yielded her fruit every month: and the leaves of the tree were for the healing of the nations. 3 And there shall be no more curse: but the throne of God and of the Lamb shall be in it; and his servants shall serve him:*

The Flaming Sword

The flaming sword, represents the word of God, especially in its power to judge. Until mankind accepts Christ, they will not be able to pass by this sword. Christ was the only man who was perfect, and capable of doing so. The rest of us, by ourselves, are not able to pass, to get to the tree of life. Only through Christ, first the church, and then the world, will be able to pass by the flaming sword, and reach the tree of life again.

Heb 4:12 For the word of God is quick, and powerful, and sharper than any twoedged sword, piercing even to the dividing asunder of soul and spirit, and of the joints and marrow, and is a discerner of the thoughts and intents of the heart.

Eph. 6:17 And take the helmet of salvation, and the sword of the Spirit, which is the word of God:

The Cherubs Wing Span, Represents a Fixed Period of Time?

On the first chart of 1845 yr circles and Cherubs in this book, we see that the span of the wings of Ezekiel's Cherubs, reaches all the way from Adam's first day, up to the second Adam's day, (1878 AD).

Sleep of Death

This is where the Bible Students believe, that the resurrection of the sleeping saints began! Contrary to popular belief, the Bible says that even the church would sleep until the last days, and then they would be resurrected to be with the Lord. Many think that the church has always gone to heaven immediately after they died, but we know that the scriptures talk of the church as sleeping in death, until the last days. See the scripture at the end of the next paragraph, for what the bible says on this. Since the 1878 date is parallel to the 33 AD death and resurrection of our Lord, it was, and is still believed, that the resurrection of the sleeping saints began in 1878 AD.

Span of Wings Ends in 1878

This booklet, seems to confirm the start of the churches resurrection, by the length of the span of the four sets of wings, that end in the year 1878 AD. Most churches at this time,

think that it has always been true, that when a Christian died, he was resurrected to heaven immediately! Contrary to that, the scriptures say that we are to sleep until the last days, and then when Christ comes, we are taken up to meet him.

1Thes 4:13-16) 13 But we do not want you to be uninformed, brethren, about those who are asleep, so that you will not grieve as do the rest who have no hope.

14 For if we believe that Jesus died and rose again, even so God will bring with Him those who have fallen asleep in Jesus.

15 For this we say to you by the word of the Lord, that we who are alive and remain until the coming of the Lord, will not precede those who have fallen asleep.

16 For the Lord Himself will descend from heaven with a shout, with the voice of {the} archangel and with the trumpet of God, and the dead in Christ will rise first. (NAU)

Resurrection of the Church begins With the Saints That are Asleep

The 1878 date, is the very end of the fourth Cherubs wing tip, and this seems to confirm that the way to life is not blocked anymore, after 1878 AD, and for that reason the first resurrection, can start then with the sleeping saints. **After that, those who are alive, will be taken up, one by one, not all at once, as many think.**

Isa 27:12 In that day the LORD will start {His} threshing from the flowing stream of the Euphrates to the brook of Egypt, and you will be gathered up one by one, O sons of Israel. (NAU)

In other words, when a faithful church member, after 1878, completes his earthly walk, the Lord resurrects him immediately, but prior to that time they had to sleep.

A Spiritual Resurrection

This resurrection, is not with a literal earthly body, but with a spiritual body.

1 Cor 15:44 It is sown a physical body, it is raised a spiritual body. If there is a physical body, there is also a spiritual body.

In other words, the world would not be able to see anything happen, like some seem to think, except the actual death of the earthly body. For that reason, we do not look for a visible literal rapture, as many do, but only an invisible, one by one, taking up of the remaining saints, as they each, individually, complete their course. As we have said, this resurrection and taking up of the saints, has been occurring since 1878, and the world has not noticed anything. Only the church has spiritually discerned it.

All Israel Will be Saved

After the full number of the church is complete, (144000), then the salvation will turn back to literal Israel, and all men in the world, who will accept the salvation, offered through Israel.

Rom 11:25-26) 25 For I would not, brethren, that ye should be ignorant of this mystery, lest ye should be wise in your own conceits; that blindness in part is happened to Israel, until the fullness of the Gentiles be come in. 26 And so all Israel shall be saved: as it is written, There shall come out of Sion the Deliverer, and shall turn away ungodliness from Jacob:

The Healing of the Nations

As soon as the church, Christ head and body is complete, we see the tree of life ready to begin the healing of the nations, with its leaves Rev 22:2, 14. The tree of life was originally found in the garden of Eden, and was a key figure in the fall, in that mankind was cut off from it. The whole plan will have come full circle in the kingdom, with the tree of life that was lost, finally restored.

The Flaming Sword Still Blocks the Worlds Way to Life

The flaming sword or God's law of justice, is still at this time, keeping mankind from returning to the garden, or in symbol back to the tree of life. All of mankind, who are willing, will need to be brought under the kingdom arrangement, and then they will be able to approach the tree of life again, and they will be figuratively able to eat from it, gaining back the life that Adam had lost.

In order to be able to do this, they have to accept the salvation that will be offered through Israel. They will have to begin to give up, all their evil practices, and beliefs. It will take the whole millennial age to accomplish this, and then they will have to pass the test of the little season, at the end. Once that test has been passed, they will figuratively have access to life again, the same life that Adam had lost for himself, and the entire race.

Salvation for the World is Available Only When the Church is Complete

As soon as the church is complete, the salvation can go to the world. That is why the Apostle Paul says that the the whole world groans, waiting for the manifestation of the sons of God, (The church).

(Rom 8:19-20) 19 For all creation is waiting patiently and hopefully for that future day when God will resurrect his children.

20 For on that day thorns and thistles, sin, death, and decay-- the things that overcame the world against its will at God's command-- will all disappear, and the world around us will share in the glorious freedom from sin which God's children enjoy. (TLB)

JEWISH AGE

28.75 OCT29 AD _____

The Lords first presence (Math 3:12)
 Jewish harvest began (13:34-35)
 New truth revealed (Math 13:52)

3.5 YRS

32.25 OR APRIL 33 _____

Messiah is cut off in the midst of the week but resurrected in 3 days. (Dan 9:27 luke 24:6-7)

1845 year judgment parallel ends. The blood of all the prophets is to come on their head (Math 23:29-39).

They knew not the time of their visitation (Luke 19:44).

7 YRS

35.75 OCT 36 _____

70 weeks of Dan 9: ends the exclusive favor to the Jews and others can take the crowns available (Acts 10:45). Gentiles can now enter into the race for the high calling.

40 YRS

68.75 OR OCT 69 _____

The war with the Jews began in 66 AD and in 69 AD the Romans led by Titus laid siege to Jerusalem, allowing no one in or out until 70 AD when he took the city.

They raised an earth wall around the city that was as high as Jerusalem's stone wall. Anyone caught in the space in between after 69 AD was crucified on top of this wall."See Jews God and History, page 105, in the chapter the sealed coffin". The Christians had fled the city before this occurred.

The destruction of the last of the Jewish resistance was accomplished by 73 AD (about 3.5 yrs later).

This was vengeance for the blood of the prophets (Matt 23:35).

The call goes on until the fullness of the Gentiles has come in (Romans 11:25). **The Gentiles are replacements for the Jews who failed to enter in.**

See Volume 2, page 201, "The Parallel Dispensations", for more information on this parallel.

GOSPEL AGE

1873.75 OR OCT 1874 AD

The Lords second presence (Math 13:30)
 Gospel harvest begins (Rev 10:4-7)
 New truth revealed (Math 24:45)

3.5 YRS

1877.25 OR APRIL 1878

Resurrection of sleeping saints on the third day 1 Cor 15:51-55, 1 Thes 4:13-18) Hosea 6:2

1845 Year judgment parallel ends. The blood of all the saints is to come on them (Rev 16:4-7).

The false church system, would also not know the time of their visitation (Math 24:39). Israel starts the gradual process of returning to their land with the establishment of Zionism.

7 YRS

1880.75 OR OCT 1881 AD

Exclusive favor to the spirit begotten ends (Rev 3:15-21). Those who reject the message of truth can lose their crowns and others can run in their place.

40 YRS

1913.75 OR OCT 1914

World War 1 breaks out. All Christians who are awake should have seen that this system was false and have come out of her my people (Rev 18:4). If not they receive of her plagues and lose their chance for the high calling.

The 2520 ends and Christ can begin to dispossess the nations. The destruction of most of the kings that were associated with the harlot, was accomplished by 1918, about 3.5 yrs after the war started. The final decline of the nations appears to be occurring more gradually than originally thought, but its still happening. The nation of Israel has been restored and the rest of the countries in the world are having major problems.

This has been vengeance for the blood of the saints (Rev 16:6).

The call goes on until the fullness of the Gentiles has come in (Romans 11:25). **These are replacements for those who lost their crowns.**

See Volume 2, page 201, "The Parallel Dispensations", for more information on this parallel.

Fixing a 19 Year Problem?

Since the next pattern, is the one that is made up of 1260 and 2520 year circles, we have decided that we need to address a problem before we consider it. Others have made the claim that the 2520 years, that points to 1914 AD, can't be possibly right, because most modern historians, date the carrying away to Babylon, from 586 and not 606 BC, as was done in the original calculations.

Since there seems to be overwhelming evidence to support their claim. There have been several new sets of records dug up, that have only 50 years recorded in that time span, which makes it difficult to support 70 years there! We have a suggestion that we are going to put forth here, that we think will fix the problem, without causing any problems with the original chronology. For the time being, this should be considered a hypothetical solution, but it appears to have some promise, so we present it here. If this proves not to be correct, we feel that the correct solution has to be something similar to this, so that the chronology is not disrupted.

We Shouldn't Bury Our Head in the Sand

If there is a problem, we would be foolish to ignore it. Not only is there a book that has been published in regard to this problem, but there are several sites on the internet, that are devoted to just this topic. They have very well documented evidence, about this problem, and even though they are directed against the Jehovah Witnesses, the topic of 1914 concern's us also. Its easy to say that the historians are mistaken, and that we will be proven correct in the long run, but proving that may be impossible, especially if we are not right!

For that reason, we have looked into this problem, and tried to find a solution to it. We started the search, with the chronology patterns in front of us, and with the conviction that the date 1914 was correct. The date looked good not only for the reason that WW1 started there, right where it was predicted, but we also had the 1845,1260-2520, and 2500 chronology patterns, showing us that the original total count of the years, had to be right. It was impossible to take any time out of the patterns without destroying them. We knew that if we took out 19 years, we would have to put it back in order to keep the patterns intact, but where?

A Possible Solution

We are going to discuss a possible solution to the problem here. This revision, involves a minor change, in how we count the years in the bible, in both the time of Joshua and the Babylonian conquest. It solves the historical problem with the Bible Student chronology, in that it would align our chronology with secular history in the time of the desolation! All of the original chronology still works with no unexplainable problems, and some things are actually better as we will see.

We have, in the past, said that the original chronology can't be changed, without disrupting the repeating patterns found in this booklet. That is still true, in that you can't cut out 19 years and put it back in just any place. Any such modification, to be successful, would have to be done in the same time area, or very close to it! If you didn't do it that way, one wheel would become lopsided with respect to another, and the chronology pattern would be destroyed. **Anything that would shorten or lengthen one cycle in regard to another, would not be a viable or acceptable solution!**

Was Joshua a Judge?

We traditionally count Joshua as a judge, but the scriptures may not actually do the same? The bible does not speak of giving them judges, until after Joshua has died!

Judg 2:8 And Joshua the son of Nun, the servant of the LORD, died, being an hundred and ten years old.

Judg 2:16 Nevertheless the LORD raised up judges, which delivered them out of the hand of those that spoiled them.

In other words, it appears that Joshua should not have been counted into the 450 years of the Judges. *(Acts 13:19-20) 19 And when he had destroyed seven nations in the land of Chanaan, he divided their land to them by lot. 20 And after that he gave unto them judges about the space of four hundred and fifty years, until Samuel the prophet. We can take the 19 years out, at the carrying away to Babylon, without disrupting the chronology, if we add it back here, since that is the time of Joshua's service to the people, before his death.*

Joshua's Length of Service Unknown?

We do have one uncertainty, in that we do not appear to have a direct scriptural statement about how long Joshua served the people after Moses died. The Jewish historian Josephus says 25 years, (Antiquities, book 5, chapt 1, par 29). The 25 years that Josephus gives us, would make it come out exact at 19 years. (25 - 6 = 19)

If Joshua Was a Judge, We Should Have Subtracted the 6 Years Back Out of the 450

The calculation would be, 25 years minus the 6 years of the dividing of the land. The six years of dividing the land, was not originally part of the 450 years of the judges, and that should give us a big clue that we had a problem with the original calculations.

In the original bible Student calculation, we counted only the later part of the time of Joshua's service into the 450 yr. period of the Judges, even though he began to serve, at the beginning of the dividing of the land, 6 years earlier. **We should have counted his entire service as part of the 450, if he was a judge.** This problem indicates, that he should have been counted separate from the Judges!

The 2520 Starts at First Desolation

The only implication of this change, is that both the 70 and the 2520 years, would have to begin 19 years earlier, at the time that Nebuchadnesszar actually made Judah a vassal state, instead of the originally considered date, which was the carrying away to Babylon. The actual date does not change from 607 BC, but all the events shift 19 years. **For that reason the 2520 years, still starts in 607 BC and runs to 1914 AD!**

A head of Gold!

We don't think that we have a problem with the different starting event, since Nebuchadnezzar was told **exactly at the time that he had conquered Israel, God says that he was the head of gold,** as described in Daniel 2:38. In other words, Israel had lost their civil authority and country to Babylon, and was ruled by it. See the timeline for detail on how this works.

For that reason, this event, as a starting point, actually makes more sense! Israel was not ruling their own country after he took control of them, but they had become subjugated to him. The country or land became a desolation for the 70 years, as far as God was concerned, since it was controlled by Babylon. From their subjugation, until the decree of Cyrus, was the 70 years of desolation.

A Problem With the 70 Years?

The proposed solution to this problem, takes the 19 years out of the traditional 70 years of desolation, and adds the 19 years needed back into Joshua's time. This keeps the total count of the years, the same as it was originally. Since there is some question regarding the 70 years, we need to review those scriptures. Here are the scriptures that deal with the 70 years.

(Jer 25:11-12)11 "This whole land will be a desolation and a horror, and these nations will serve the king of Babylon seventy years.12 "Then it will be when seventy years are completed I will punish the king of Babylon and that nation,' declares the LORD, 'for their iniquity, and the land of the Chaldeans; and I will make it an everlasting desolation.

Jer 29:10 "For thus says the LORD, "When seventy years have been completed for Babylon, I will visit you and fulfill My good word to you, to bring you back to this place.

2 Chr 36:21 The land enjoyed its sabbath rests; all the time of its desolation it rested, until the seventy years were completed in fulfillment of the word of the LORD spoken by Jeremiah. (NIV)

Dan 9:2in the first year of his reign, I, Daniel, perceived in the books the number of years which, according to the word of the LORD to Jeremiah the prophet, must pass before the end of the desolations of Jerusalem, namely, seventy years.

At first glance, it appears that we have a problem, but if you read the text very carefully, you should notice that the original text from Jeremiah, does not say that the desolations of Jerusalem were to be 70 years, but it says that **“the nations should serve Babylon 70 years”**. The second verse from Jeremiah, says that the 70 years was for Babylon, not Israel. The 2 Chron, scripture talks about the land, not Jerusalem, enjoying its rest for 70 years.

We also see a very important point, in that Daniel says that there would be 70 years, until the end of desolations, “plural”, of Jerusalem. The only way that could be true, is if we counted all the times, 3-4, that Nebuchadnezzar carried people away to Babylon. If this is correct all of the scriptures which we have just considered, date the 70 years from the first time that Nebuchadnezzar conquered Israel, and made them a vassal state, which was the same time he conquered the other nations around them.

Another Problem With Traditional Dating

We have two other scriptures that we need to consider yet.

*Zech 1:12 Then the angel of the LORD said, "O LORD of hosts, how long will You have no compassion for Jerusalem and the cities of Judah, with which You have been indignant **these seventy years?**"*

*Zech 7:5 "Say to all the people of the land and to the priests, "When you fasted and mourned in the fifth and seventh months **these seventy years**, was it actually for Me that you fasted?"*

The question in regard to these two scriptures, is to what 70 years is Zechariah speaking of? We think that Zech is speaking of a different

70 year period than Jeremiah. But before you get excited and say, aha, there is the flaw in your proposal, please notice that if we are using traditional Bible Student chronology, this could not be 70 years from the fall of the temple either. At the time of the laying of the foundation of the temple, it would have been about 90 years.

Only 586.25 Works with Zechariah's 70

Only if we use the 586.25 BC date, as the last carrying away to Babylon, do we get 70 years to the fourth year of Darius. **For that reason, we can only conclude, that this is a different 70, than the other one, and that it only works from the original temple destruction, if we use the modified chronology!**

An Objection Considered

One objection to this solution, is that many think that the entire country needed to be barren or without any people, for the full 70 years, for this to be fulfilled. We don't think that is correct, since if that were true, there would also be a major problem with the traditional view. Four years after the destruction of the temple, there were still people living in the land, so we would be short at least four years, from making the full 70 anyway, Jer 52:30!

As far as the change and this booklet are concerned, we do not have to change any of the patterns or the dates! The only thing that changes, would be that instead of 607 BC being the carrying away to Babylon, it would be the date that Nebuchadnezzar conquered the country of Israel.

The Pattern Gains An Important Date

We actually get an enhancement, in the 1260 and 2520 year chart, in that one of the circles on that chart, exactly intersects the date that the ten tribes were carried away.

Since the carrying away of the 10 tribes belongs to the topic of civil power, we would be surprised if it didn't belong on this pattern. With that date, and the two dates past 1914, we then have 10 dates on the chart. Ten is a perfect ordinal number, dealing with civil or worldly power!.

A Timeline of 7000 Years?

We are developing a timeline, as a separate supplement to this book, where we add up all of the chronology from the time of Adam until, until the end of the 7000 years. This table will have a traditional time line as well as the modified version, so that the reader can compare and study the differences. The modified time-line fixes the problem with the 2520 years, so that it conforms to secular history, yet still reaches to 1914 AD.

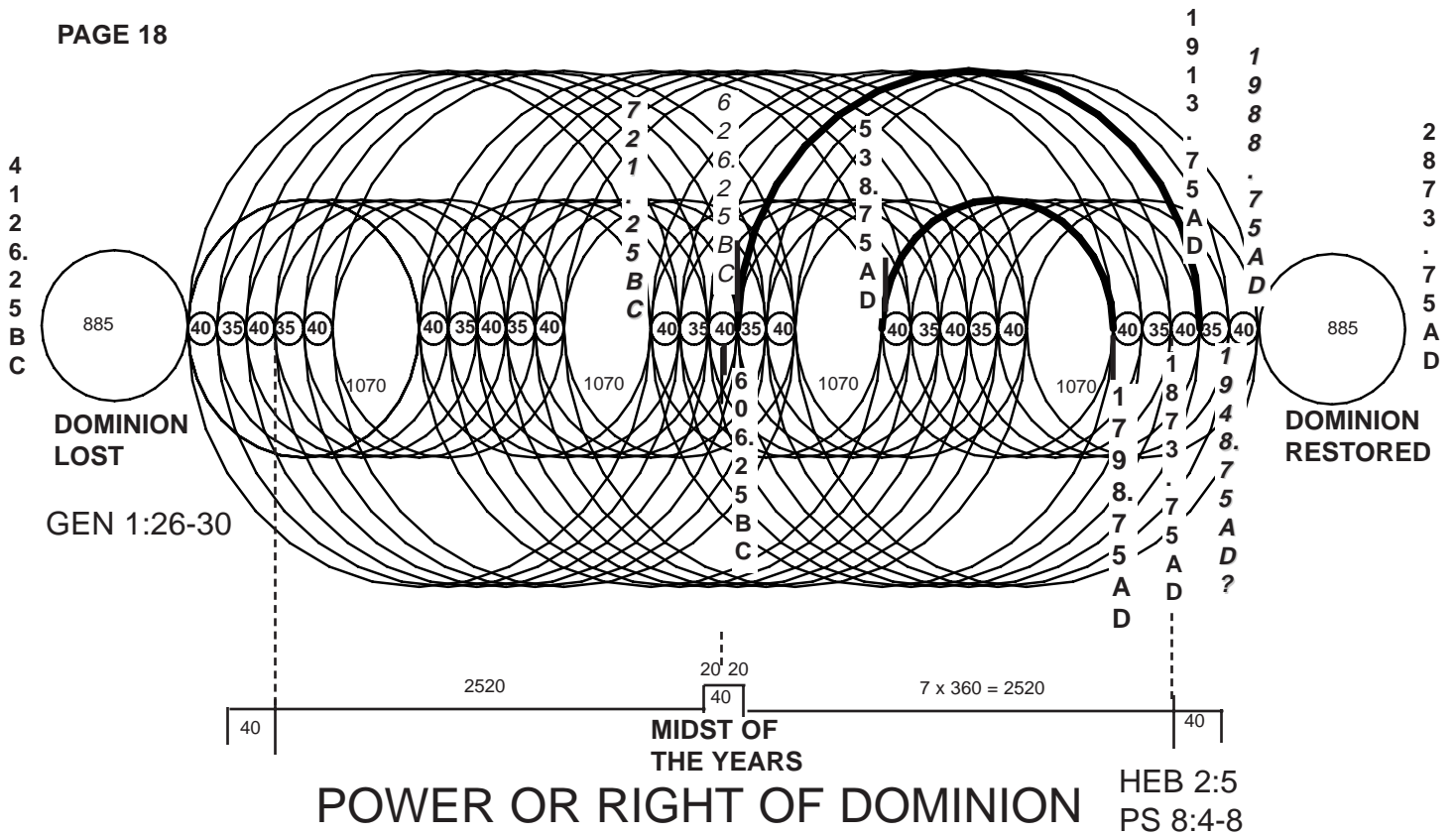

1260, 2520 Year Pattern

The above pattern, helps to prove the 1260 and 2520 year chronology correct, as found in “the Studies in the Scriptures”, volume 2, chapter 4 and volume 3, chapter 1. The large darkened in arc, is the 2520 years that runs from Oct 607 BC, to Oct 1914 AD. The smaller darkened arc, is the 1260 years that runs from 539 AD to 1799 AD. An important similarity, between the 1260-2520 year chart, and the 1845, is they are symmetrical around the midst of the 7000 years.

We are not going to explain how this chart was derived at this time, because of the complexity involved in its construction. We are going to explain this chart, as if we were sure that it is correct to shift 19 years from the end of Kings, to the time of Joshua, as proposed in the previous section.

After the 19 year change, we realized that we had been ignoring a couple of dates that dealt with civil power, in order to limit the chart to 7 dates. One of those dates was 1873.75, which was when the Lord returned and the other one was 1988.75 when Communism fell. If we add the new date of the destruction of the ten tribes, and the the other two, we have a total of 10 dates.

Ten Dominion Dates

Of the ten dates we see that seven of them represent failures or wrong doing regarding dominion. Three of the dates belong to God and represent success towards the kingdom. We will number them F for failure and S for success, so that you can see which is which.

(1) The first date, is 4126.25 BC, or the beginning of the first 1000 yr. day, or Adams day. This is the date at which Adam lost control over the dominion that had been given to him, and he was forced out of the garden. (1F)

(2) This is the extra date that we pick up, if we make the 19 year change. In 721.25 BC, the 10 tribes were carried off by the Assyrians. This date fits very well, in that this is a loss of dominion! (2F)

(3) There is another date in the center of the years, at 626.25 BC. That date is not actually intersected by circles on this chart, but everything revolves around it, and its found on the other two charts. (1S) If we had to replace this date we would look at 1948.75.

(4) The next date is very important, since it’s the start of the 70 years desolation, and the 7 times of Daniel, (606.25 BC). Israel lost its dominion at that time to Nebuchadnezzar. In calculating this date, we need to caution you that you will only get that date for the first capture of Judah, if you use 586 BC as the date of the final carrying away of Judah, to Babylon. (3F)

(5) The third date is the beginning of the rise of the false system to civil power 538.75 AD. (4F)

(6) Number four is the end of the false reign 1798.75 AD. (5F)

(7) This date is the beginning of the Lords second presence, and it signals his return to reign with dominion over the earth, which is the topic of this chart. We originally dropped this date from the list, in an attempt to get only seven dates, but that appears to be incorrect, because it definitely is a dominion date. (2S)

(8) We then come to number six at the end of 2520 years which is the end of the times of the Gentiles in 1913.75 (Oct 1914). The destruction of the kings who reigned illegally with Papacy began here, and was largely accomplished by the end of WW1. ((6F)

(9) This is 1988.75 AD, (Oct 1989), which was a date that even the

world recognizes as important, because communism fell then. This probably marks the beginning of the final decline of “all” the nations, not just those who had reigned with Papacy. (7F)

Collapse of Communism

In regard to the dates that overlap 1914 on this chart, we think that the Oct 1989 date should be counted for sure, as a valid date, because of the collapse of Communism, that happened then.

(10) The last or seventh date on the chart, is 2873.75, Oct 2874, which is where mankind will have the dominion or right to rule, restored back to them. Christ and the church, will have custody of this right to rule, during the millennium. (3S)

The one other interesting date, that we have looked at on this pattern, is 1948.75, Oct 1949. This appears to be 1 year to late for Israel becoming a nation, so its probably not an intersect date, but it still could be marking off the period of time in which Israel becoming a nation was to be accomplished?

End of Gentile Times

We see both chronologically, and historically, that 1914 was the date at which the times of the Gentiles expired, and vengeance began. Shortly after that time and onward, Israel could start to return to their land, and historically they began to own land in 1917.

The question of the times of the Gentiles, is further related to who has control of Israel. The king of Israel, lost this control to Nebuchadnezzar. The control of the country, was not given back to Israel, all through the 2520 years, until we arrive at the end of the age and 1914-1948. See “Studies in the scriptures”, volume 2, page 76-77.

Even though most of the original church state kings, lost their crowns in 1914, the remnants of the nations, still do not want to give up their power as yet. The time of trouble that we are in since 1914, is designed to wear the nations out, and make them want the peace of the kingdom. The final end and decline in power of the nations, which probably started in 1989, will eventually open the way for the full reign of righteousness that is to come. This is not to say, that these countries will not exist in some form for a time, but their power will be greatly reduced. This has already happened to the former Soviet Union, and even the U.S to a certain extent.

Smiting of the Image

The smiting of the image on its feet, took place from 1799-1914. In 1799, Papacy was separated from its civil power, and historically the kings that had been associated with that system were shattered in WW1(1914). It might be possible to view the smiting, as starting as early as the reformation in 1517, but we are not sure of that broad an application at this time? See the special explanation for a possible outline regarding that possibility.

(Dan 2:34-35) 34 Thou sawest till that a stone was cut out without hands, which smote the image upon his feet that were of iron and clay, and brake them to pieces.

35 Then was the iron, the clay, the brass, the silver, and the gold, broken to pieces together, and became like the chaff of the summer

threshingfloors; and the wind carried them away, that no place was found for them: and the stone that smote the image became a great mountain, and filled the whole earth.(KJV)

Crushing and Grinding

Regardless of where we start it, this process is not completely done yet, since many of the original pieces still exist. As we see in Dan 2:34, it first talks about the image being smitten, and then it describes a further process, in which the pieces are crushed together. This crushing and crumbling process, has continued past WW1. We see that this has actually happened historically, by the much larger number of countries that now exist. After the second crushing and grinding of WW2, most of the old world colonial empires, crumpled into even more countries.

The Whirlwind

The last thing Daniel mentions, is the wind that carries away the pieces, so that no trace of them can be found, and he then describes the rock which became a mountain, and filled the whole earth. Wind seems to represent political change in the Bible, whether by war or by political upheaval, (See Dan chapter 7). This wind of change, has been blowing since 1914, but it has become much stronger since Oct 1989 in that we see almost the entire eastern European communist countries, being overturned by political change and dissatisfaction. This may be more like a whirlwind phase, that is more destructive than a regular wind.

The date 1989, seems to point to a further completion of what we had originally expected to happen in 1914. As we see in the Daniel account and the smiting of the image, there were at least three main phases to the process, the smiting, the crushing and the blowing away by the wind.

The date 1989, appears to mark a point in which progress towards the kingdom, has greatly speeded up. This last date, would seem to be the final phase, in which the wind, which has been blowing since 1914, is beginning to blow harder. It looks like the power of the eastern block, was removed first. We think the western block of countries will not escape either, and they will follow close behind as the final trouble releases.

Fighting for Israel like the Days of Old?

If this is true, we should be seeing a lot of political change after 1989, as represented by the symbol wind and so far this has been happening. We should also see these changes helping the nation of Israel survive their enemies, and this is also true, in that for example, the Palestinians lost their financial support from the Arabs, which makes it very unlikely that they can mount another major campaign against Israel. Russia is so broke, that they have ceased supplying Israel’s enemies, with free weapons!

If we examine how God fought for Israel, in the original kingdom, we see that he used similar events to keep them safe. Only in the extreme cases, did he actually come out into plain view, and openly defeat their enemies. In other words, we can see the beginnings of God fighting for them like in the days of old! When we get to the time where it has become obvious, we will have fully arrived at the kingdom.

Is There a Vision For This Pattern?

Since we saw that the 1845 year chronology pattern, had a graphical representation of Ezekiel's vision, it would be reasonable to ask about the 1260 and 2520 year pattern? It turns out that there are two other places in the Bible, that have similar visions to Ezekiel's. Isaiah saw Seraphim which he describes in Isaiah 6:, and John saw 4 living creatures, in Revelation chapters 4 and 5.

Revelation Chapter 4 and 5

Since John saw 24 elders around Gods throne, and there are 24 small circles about a central circle in the patterns below, we are going to start with the Revelation account, and see if it matches the description given.

24 Elders and a Central Throne

If you look just above the large circular pattern below, we have separated out the 25 small colored circles, in order to make them easier to see. It says in Rev. 4:2, that there was a throne set in the

heavens, and in verse 4, it tells us that there were 24 seats about or around the throne and on the seats 24 elders. **We don't see the actual elders, but only the seats that they sit on.** There are 12 seats on the left and 12 on the right.

The Vision is Graphically Represented

It should be realized that the items in this vision are graphically represented and we are not going to see pictures of things that look as though they were taken with a camera.

Jehovah's Throne is in the Center

The central seat, with the cross, is Jehovah's throne, with Christ on his right hand, and its centrally located to the scene.

While these features might not be the same as what you would expect from reading the original description, you should note that they and other features to follow, fit the description as given in a graphical sense and each feature has the right number of parts!



24 SEATS WITH THE THRONE IN THE CENTER

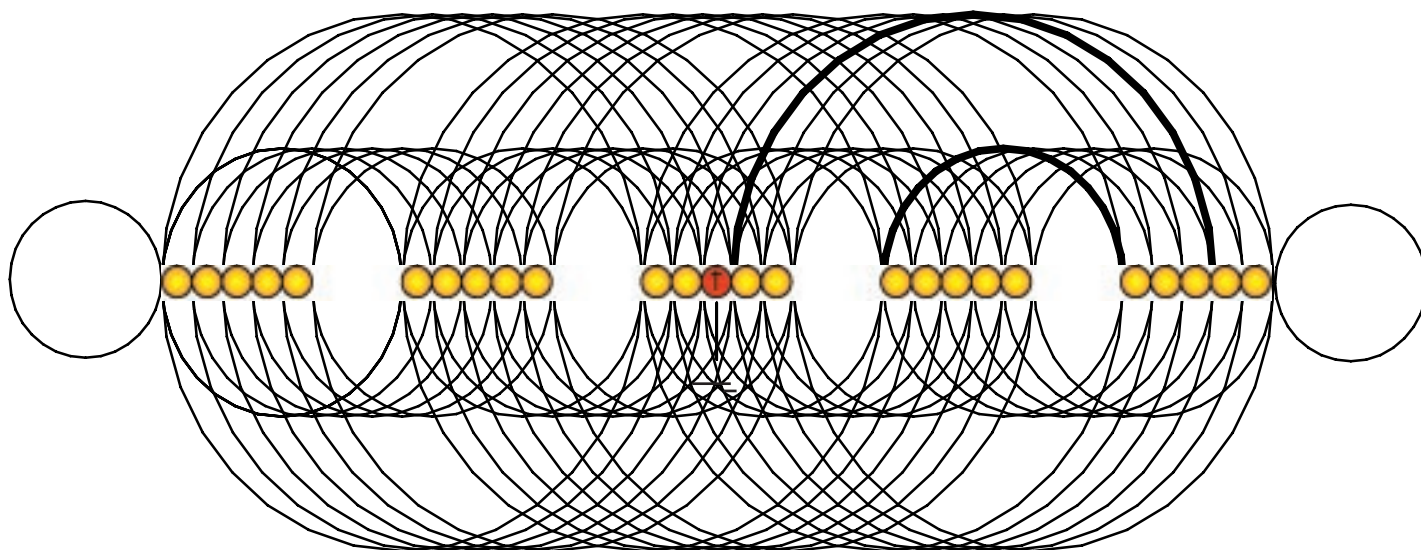

Rev 4:2-11) 2 Immediately I was in the Spirit; and behold, a throne was standing in heaven, and One sitting on the throne. 3 And He who was sitting {was} like a jasper stone and a sardius in appearance; and {there was} a rainbow around the throne, like an emerald in appearance.

4 Around the throne {were} twenty-four thrones; and upon the thrones {I saw} twenty-four elders sitting, clothed in white garments, and golden crowns on their heads.

5 Out from the throne come flashes of lightning and sounds and peals of thunder. And {there were} seven lamps of fire burning before the throne, which are the seven Spirits of God;

6 and before the throne {there was something} like a sea of glass, like crystal; and in the center and around the throne, four living creatures full of eyes in front and behind.

7 The first creature {was} like a lion, and the second creature like

a calf, and the third creature had a face like that of a man, and the fourth creature {was} like a flying eagle.

8 And the four living creatures, each one of them having six wings, are full of eyes around and within; and day and night they do not cease to say, "HOLY, HOLY, HOLY IS THE LORD GOD, THE ALMIGHTY, WHO WAS AND WHO IS AND WHO IS TO COME." 9 And when the living creatures give glory and honor and thanks to Him who sits on the throne, to Him who lives forever and ever,

10 the twenty-four elders will fall down before Him who sits on the throne, and will worship Him who lives forever and ever, and will cast their crowns before the throne, saying,

11 "Worthy are You, our Lord and our God, to receive glory and honor and power; for You created all things, and because of Your will they existed, and were created." (NAU)

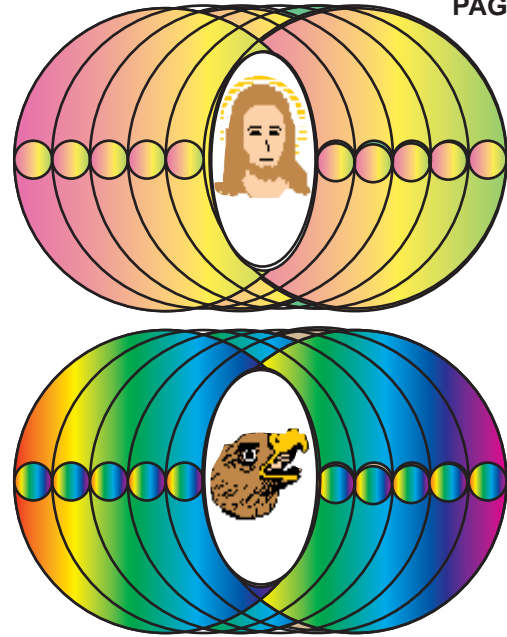
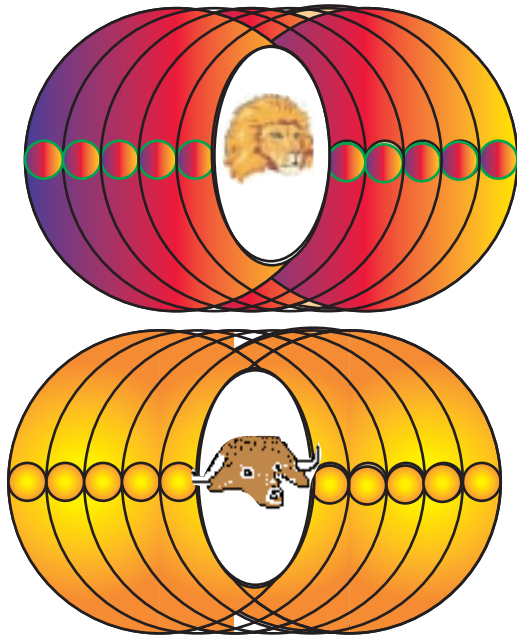

FOUR
LIVING
CREATURES

**HOLY, HOLY HOLY IS JEHOVAH GOD THE ALMIGHTY
WHO WAS AND WHO IS AND WHO IS COMING REV 4:8**

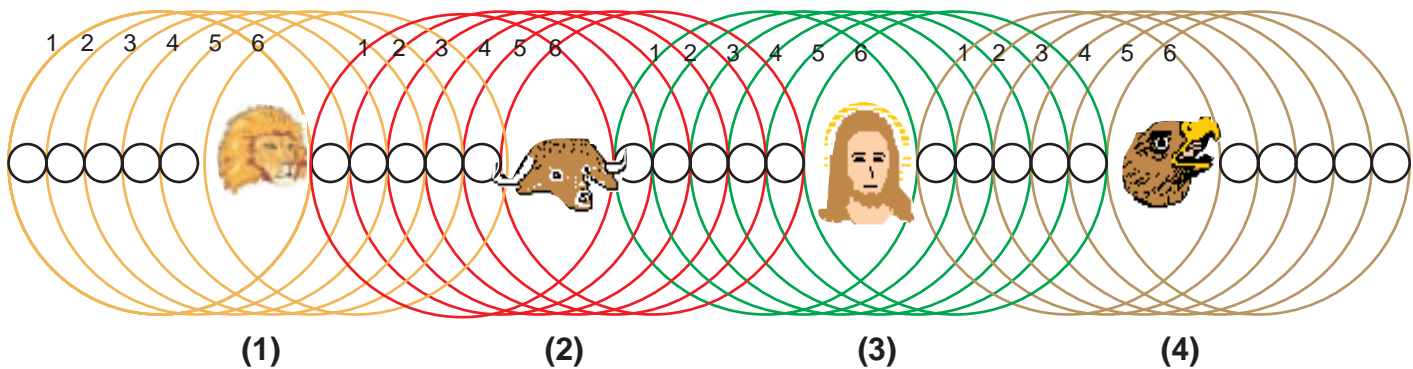

THE FOUR LIVING CREATURES ABOUT THE THRONE

If we look at Rev 4:8, in an interlinear Greek text, it seems to tell us that the 4 living ones had, six wings apiece, round about. From this, we should expect to find 6 round wings, for each of the 4 living creatures or beasts. The medium sized circles just above, are cut out of the larger repeating pattern. The 6 circles, which represent the 6 wings, are darker or red on living creature two.

Six Circles, Represent Each Creatures Wings and its Body

What we see, are 6 overlapping circles or round wings. To fit the description given in the bible, there must be 4 sets of these, one set for each of the living ones. We have numbered each set of wings 1-6, and have placed numbers 1-4, in brackets () below each.

The bodies and face of the living ones, are located in the large open spaces central to each creature, and they are formed by each set of 6 wings. The creatures are separated and shaded in at the top of the page, to make them easier to see.

4 Attributes of God

The four living creatures, represent the 4 attributes of God, wisdom, justice, love, and power. God has all these attribute, in perfect harmony and balance with each other.

Jesus Has the Same Attributes

These attributes are also found in Jesus, because he is the express image of the Father.

- (1) Jesus is called the lion of the tribe of Judah in Rev 5:5 (POWER).
- (2) An Ox was sacrificed on the altar and this represented Jesus and his sacrifice for us (Heb 10:3-10 (LAW OR JUSTICE)).
- (3) Jesus is the man who redeemed Adam and through him the entire human race (LOVE).
- (4) In Exodus 19:4-6 we see that the Lord figuratively carried Israel on the wings of an eagle. In Rev 12:14 we see the church given the wings (old and new testament) of a great eagle (Jesus, who had far sighted (WISDOM)).

The Positions of the Seven Lamps?

Since the lamps are directly before the throne, we need to look at the central portion of the diagram below, to see if there is anything different about that area. If we examine the centrally located portion of the diagram, it can be seen that there are 7 points represented in it. To the left and right of circle 11 are two points. To the right of 12 is the third. The center of the years, 626.25 BC, is no. 4 and to the left and right of 13, are two more making six. To the right of number 14, is the seventh. The central section of the chart, is the only place where there are a group of 7 possible points, Rev 4:5. We have placed a lamp stand in front, to attempt to show this feature. The other groups, only have six points, because they do not have the center point of the years, 626.25 BC!

24 ELDERS WITH GOLDEN CROWNS AND WHITE GARMENTS, WORSHIPPING THE THRONE

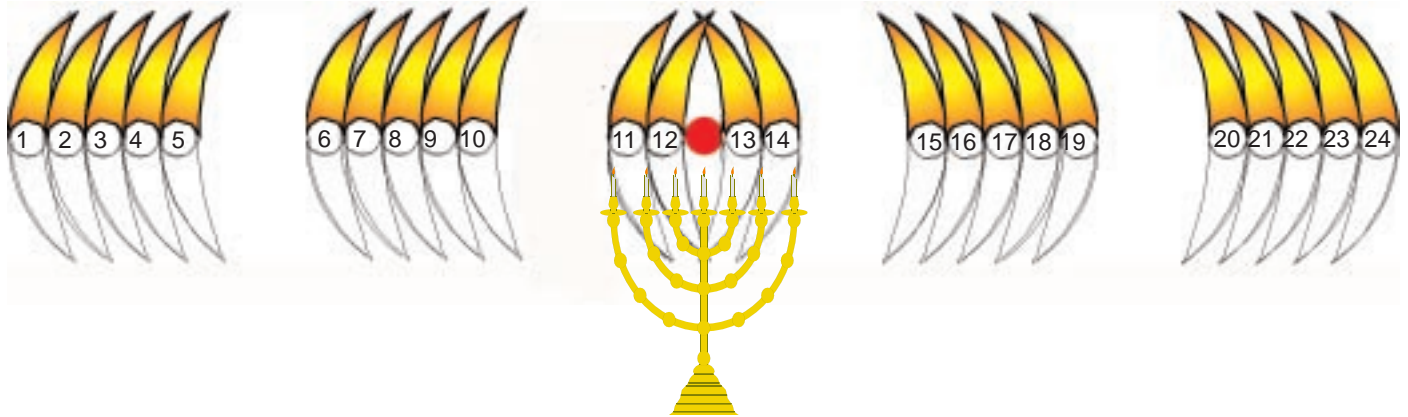

Elders and Crowns

In this section, we have a view of the elders and their crowns. It says that the elders in Rev, chapter 4 and 5, were bowing down towards the throne and worshipping, and that’s what they are shown doing here! The golden crowns on their heads, are tipped towards the throne, and we see their white garments hanging down below them. You may be able to see the garments and the crowns more clearly on page 25.

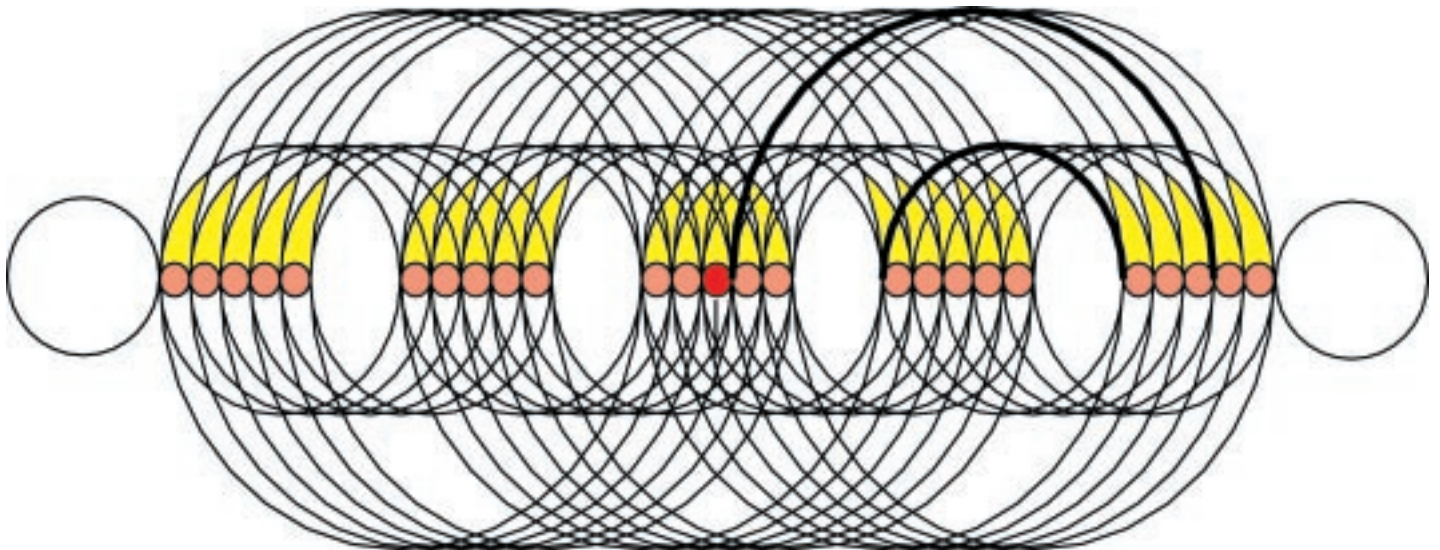

Rev 4:4 And round about the throne were four and twenty seats: and upon the seats I saw four and twenty elders sitting, clothed in white raiment; and they had on their heads crowns of gold.

*Rev 4:9-10) 9 And when those beasts give glory and honour and thanks to him that sat on the throne, who liveth for ever and ever,
10 The four and twenty elders fall down before him that sat on the throne, and worship him that liveth for ever and ever, and cast their crowns before the throne, saying,*

*Rev 4:8 Each of these Living Beings had six wings, and the **central** sections of their wings were covered with eyes."*

In Rev. 4:8, it tells us that the wings were full of eyes. We have separated the eyes out of the pattern of 1260, 2520, circles, in order to make them easier to see. These eyes are very similar to Ezekiel's vision, in that they are formed by overlapping circles. We have turned two of them over, into a more normal orientation, so that they are easier to see.

In Rev 5:6, we are told that the Lamb had 7 eyes and seven horns. If we ignore the central throne, we could find seven eyes on the one side of the throne, and seven horns on the other. The eyes would look like horns, if shaded solid, as we have done directly below the two horizontal eyes.

That there are seven eyes, represents God's ability to see and know all things, which he has given to his son Christ. The seven horns would also represent complete power, which again had belonged to God, but now the lamb has, because he was faithful.

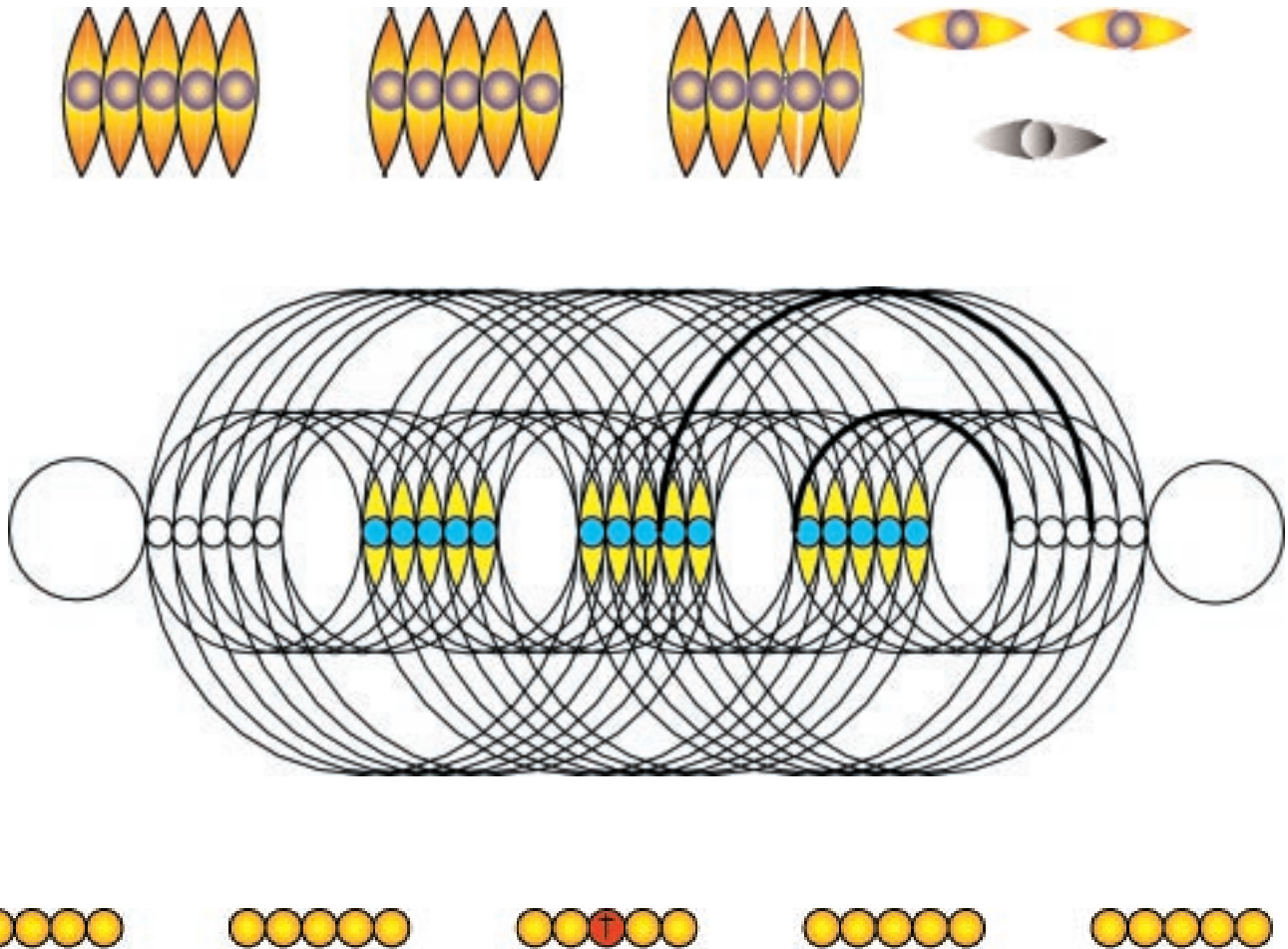

GOLDEN BOWLS CONTAINING INCENSE, WHICH REPRESENTS THE PRAYERS OF ALL THE SAINTS

Prayers of "All" the Saints

That each of the 24 elders has incense in his bowl, would seem to indicate, that when Christ died, he made it possible for all of the righteous prayers of all the saints to be answered. This possibly would be not only the current church, but also all of the prayers of the old testament prophets and others who have prayed for help and salvation in times past. Because of what Christ has done in paying the ransom, it has made it possible for these prayers to be answered This would include prophecies, that for example asked how long before God was going to do something about wickedness.
Hab 1:2-4) 2 How long, O LORD, will I call for help, and you will

*not hear? I cry out to you, "Violence!" Yet you do not save.
 3 Why do you make me see iniquity, and cause {me} to look on wickedness? Yes, destruction and violence are before me; strife exists and contention arises.
 4 Therefore the law is ignored and justice is never upheld. For the wicked surround the righteous; therefore justice comes out perverted. (NAU)*

Gods Answer Can Now Go Forth!

Hab 1:5 "Look among the nations! Observe! Be astonished! Wonder! Because {I am} doing something in your days-- you would not believe if you were told. (NAU)

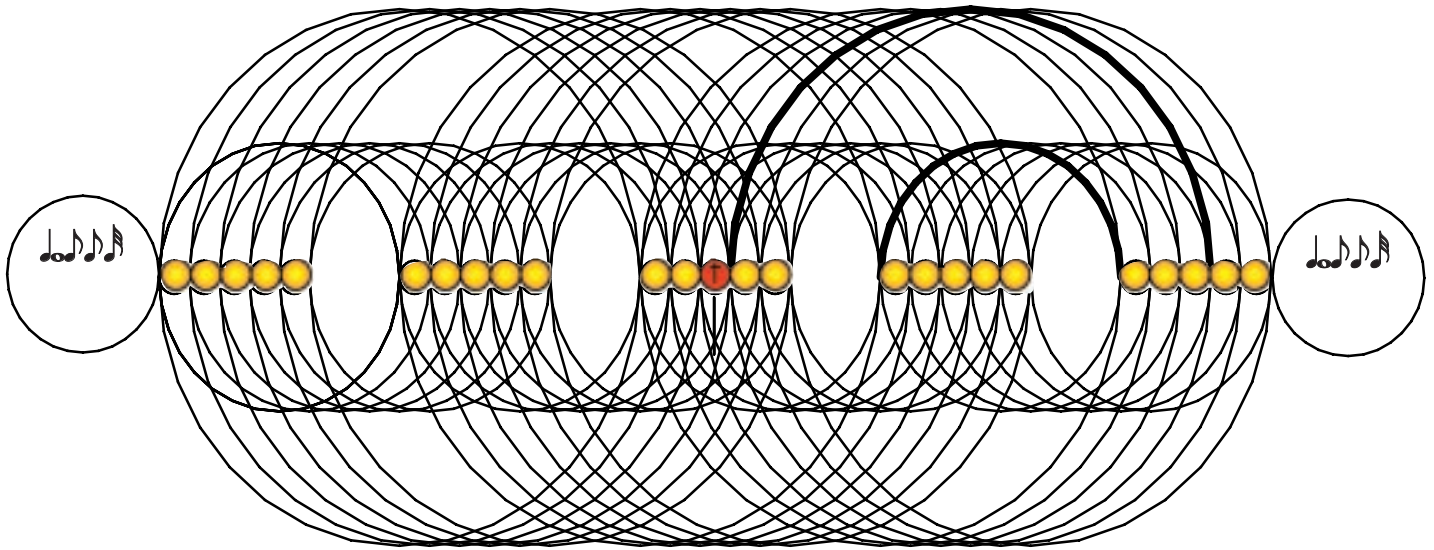

Rev 5:8 When He had taken the book, the four living creatures and the twenty-four elders fell down before the Lamb, each one holding a harp and golden bowls full of incense, which are the prayers of the saints. (NAU)

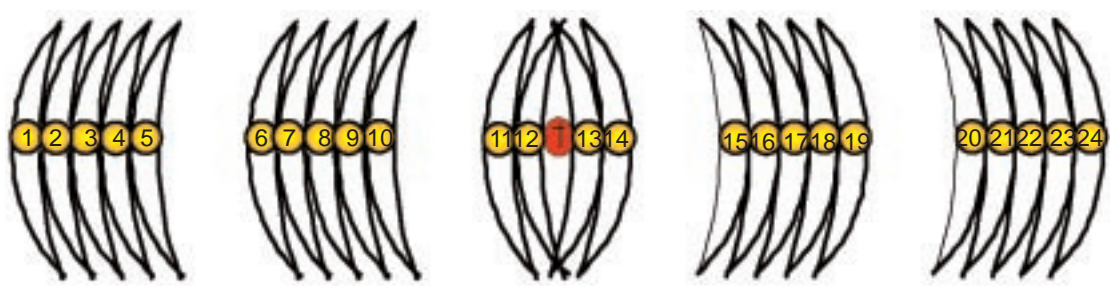

EACH ELDER HAD A GOLDEN BOWL AND A HARP OR BOW

Bowls and Harps

The bowls of Rev 5:8 are represented above, by the 24 circles or seats, around the central throne. Each elder also has a bow or musical harp with him just as we see graphically represented above. The 24 elders seem to represent the 24 divisions of the old testament, as they were divided up by the Jews at the time of the first advent. In this vision, the seats they sit on, represent the judgment authority of God's word, especially as represented in the law. This would be like a heavenly Sanhedrin, which in this case would be God's court of law.

A New Song of Restitution and Salvation

Even though the symbol changes meaning in Rev chapter 5, the message stays the same. If each of the elders represent an old testament division of God's word, then the golden bowls, represent the message, prayers, and prophecy of God's Old Testament word, given by his saints and prophets. The old song of Moses, had God's plan hidden in it, in types and shadows, but now after the Lamb has been slain, it has a new song or message of salvation to give to us. The lamb was found worthy to bring salvation to the world.

Rev 5:8-9) 8 Now when He had taken the scroll, the four living creatures and the twenty-four elders fell down before the Lamb, each having a harp, and golden bowls full of incense, which are the prayers of the saints.

9 And they sang a new song, saying: "You are worthy to take the scroll, and to open its seals; for You were slain, and have redeemed us to God by Your blood out of every tribe and tongue and people and nation, (NKJ)

The Sweet and Harmonious Song of Moses and the Lamb

The harps and messages of truth that the bowls represent, help us to sing the song of Moses and the Lamb, the Old and New Testament, in harmony with God's plan of the ages! It's not true as some claim, that you can play any old tune on the Bible. If you look at the complete diagram of circles, you can see that all of the harp strings, are tied into one complete unit. These strings are all interconnected through the central throne, showing that the song of Moses and the Lamb are in harmony with God and his throne. Its only possible to sing in harmony with God and his plan, if you are using the harp of God, or the Bible correctly, and singing of the salvation provided through the Lamb.

THE EMERALD RAINBOW AROUND THE THRONE

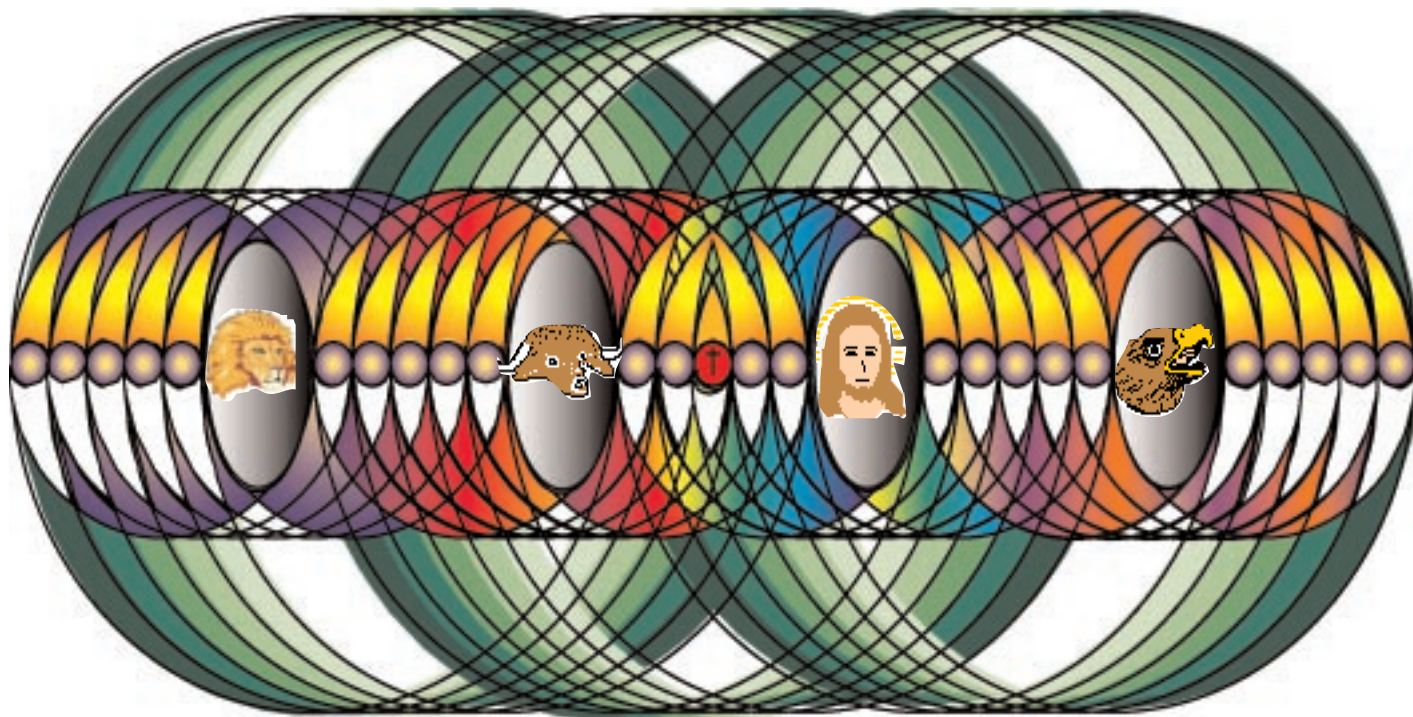

THE EVERLASTING COVENANT

Rev 4:3 And the one who sat there, had the appearance of jasper and carnelian. A rainbow, resembling an emerald, encircled the throne.

The large green shaded circles above, represent the rainbow around the throne. The rainbow that we see in Rev. 4:3, was like an emerald, (green), representing life. The word green is Strong's #4664 (emerald), which is from #4665 (The emerald or green gem so called).

The golden crowns on the heads of the elders, are represented by the gold colored shapes, just above the 24 small circles or seats, and the white garments, are the white that hangs down under each.

The Rainbow Represents a Covenant

We think the rainbow seen here is representative of a covenant. The reason for this, is that the first place that we see a covenant in the bible, is the rainbow covenant that God made with mankind after the flood.

*(Gen 9:9-17) 9 And I, behold, I establish my covenant with you, and with your seed after you; 10 And with every living creature that is with you, of the fowl, of the cattle, and of every beast of the earth with you; from all that go out of the ark, to every beast of the earth. 11 And I will establish my covenant with you; neither shall all flesh be cut off any more by the waters of a flood; neither shall there any more be a flood to destroy the earth. 12 And God said, **This is the token of the covenant which I make between me and you and every living creature that is with you, for perpetual generations: 13 I do set my bow in the cloud, and it shall be for a token of a covenant between me and the earth. 14 And it shall come to pass, when I bring a cloud over the earth, that the bow***

shall be seen in the cloud: 15 And I will remember my covenant, which is between me and you and every living creature of all flesh; and the waters shall no more become a flood to destroy all flesh. 16 And the bow shall be in the cloud; and I will look upon it, that I may remember the everlasting covenant between God and every living creature of all flesh that is upon the earth. 17 And God said unto Noah, This is the token of the covenant, which I have established between me and all flesh that is upon the earth.

Most Likely the Abrahamic

In the Rev 4: vision, the covenant that is most likely being shown, is the Abrahamic or everlasting covenant. The Abrahamic covenant, was Gods promise that through his seed, (Christ), he was going to bless all the families of the earth.

(Gen 22:16-18) 16 And said, By myself have I sworn, saith the LORD, for because thou hast done this thing, and hast not withheld thy son, thine only son:

17 That in blessing I will bless thee, and in multiplying I will multiply thy seed as the stars of the heaven, and as the sand which is upon the sea shore; and thy seed shall possess the gate of his enemies; 18 And in thy seed shall all the nations of the earth be blessed; because thou hast obeyed my voice.

There is a Heavenly and an Earthly Seed

The Abrahamic promise had to wait for Christ, the seed to be offered up as a sacrifice before it could begin to bless. The heavenly seed of the Abrahamic covenant, is the church who are being developed as ministers of the new covenant, during the gospel age, and the sand of the sea shore, represents the earthly class, which will get their salvation during the millennium.

The vision of the emerald rainbow, in chapter 4, is at a time in

which the ransom price had not yet been paid. We don't see the seed, or the Lamb, until chapter 5, when he (Jesus), was found worthy to open the scroll, because he had been faithful to God's plan.

The rainbow in Rev 4:3, is not multi colored like a regular rainbow, but is green in color. Green represents life and Abraham's covenant had this promise of life in it, but it required the seed to come before it could begin to bless.

The Restitution of All Things

The church, or stars of heaven, are to be blessed first, because the heavenly seed needs to be completed, before the covenant can bless the world. In the millennium, new life will spring up in the world of mankind, which is represented by the sand of the sea shore, as described in the promise to Abraham. This will bring about the restitution of all things, which comes through this covenant.

(Acts 3:19-21) 19 Repent ye therefore, and be converted, that your sins may be blotted out, when the times of refreshing shall come from the presence of the Lord;

20 And he shall send Jesus Christ, which before was preached unto you:

21 Whom the heaven must receive until the times of restitution of all things, which God hath spoken by the mouth of all his holy prophets since the world began.

The emerald rainbow, or Abrahamic covenant, in Rev 4:3 changed, after Christ paid the ransom price and became the seed. The rainbow, then changed, to represent the new covenant or testament.

God's Plan is Magnified

While it doesn't show us a normal multi colored rainbow in chapter 5, its most likely changed to a more normal rainbow, or in other words, transformed to represent the new covenant. **Instead of only one facet or color of truth, God's plan has now blossomed, and has many different aspects, that weren't understood before the coming of the seed.**

We see the rainbow covenant, later on in the strong angel, in Rev 10:1, which is the only other place in Rev, where a rainbow is found. The emerald colored rainbow, may have at that point, become multi colored, representing the magnification of the original Abrahamic promise, into the promise of the new covenant.

And I saw another mighty angel come down from heaven, clothed with a cloud: and a rainbow was upon his head, and his face was as it were the sun, and his feet as pillars of fire: (KJV)

This also reminds us of 2 Cor 3:5-11, where it talks about the great glory that Moses face had shone with, and how much greater the glory of the new covenant was.

2 Cor 3:6 Who also hath made us able ministers of the new testament; not of the letter, but of the spirit: for the letter killeth, but the spirit giveth life.

7 But if the ministration of death, written and engraven in stones, was glorious, so that the children of Israel could not steadfastly

behold the face of Moses for the glory of his countenance; which glory was to be done away:

8 How shall not the ministration of the spirit be rather glorious?

9 For if the ministration of condemnation be glory, much more doth the ministration of righteousness exceed in glory.

10 For even that which was made glorious had no glory in this respect, by reason of the glory that excelleth.

11 For if that which is done away was glorious, much more that which remaineth is glorious.

While the glory of the law covenant, was so great that the people couldn't bear to look upon Moses, the new is so glorious, that Paul was blinded by the sight of the anti- typical Moses, (Christ)!

The Abrahamic and its added on part, the old law covenant, are transformed or renewed into the promise of the new, by the intervention of Christ, when he paid the price for us. Before that time, no one could keep the strict letter of the law, but now we have the throne of grace to come to, when we make mistakes.

Just as what happens in nature, this rainbow shows us that after the stormy time of trouble that we are in now, peace will come to the earth. Mankind will have to learn many lessons first, some of which some are portrayed in the book of Rev. Eventually peace will come to the earth through the New Covenant, that will be established with the world in the next age, (See Isaiah 54:6-10).

THE 24 ELDERS

The most likely interpretation regarding the 24 elders, is that they represent the 24 divisions of the old testament, as they were originally divided up by the Jews. We note that the Hebrew scriptures, as compiled by the Jews, back in the time of Christ, were divided into 24 divisions. This is shown in Lesser's translation of the old testament, as well in the back of the Companion Bible, where it lists the books of the old testament, as originally given by the Jews.

While there are not actually 24 books, they had grouped all of the minor prophets into one book, which then made the number of books add up to 24. This division of 24, actually existed in the time of the first advent, when Jesus walked the earth and also at the time that John wrote Revelation. It appears likely that the intent of the prophecy of the 24 elders, was to picture the word of God, as represented in the old testament. This fits very well in symbol, in that the 24 seats could then represent the authority of God's word and its judgmental power. What else has more authority, than God's word (2 Tim 3:15-17). The 24 seats would be a heavenly Sanhedrin.

1. thronos ^2362^, "a throne, a seat of authority," (from Vine's Expository Dictionary of Biblical Words)

The Elder is One of the Prophets

We find a special case, in Rev 7:13-17, that may help to show that the elders represent the old testament scriptures. One of the 24 elders, is seen in the vision of the great company. That particular elder asks John, who the great company is, and John answers back "**you know My Lord**".

If the 24 elders represent the books of the old testament and John is saying that one of the elders or prophets knew who the great company was, then we should find an old testament prophet or book, which describes the great company for us, in great detail, paralleling Rev chapter 7.

Unfaithful Levites

If we turn to Ezekiel 44:4-16, we find a description that fits chapter 7, of Rev, almost exactly. We see unfaithful Levites, who had transgressed against God, and some of the things they did wrong. **God says that because of the things they did, they would not be able to come before him in the temple. Yet he says, they would still have the service of the people in the court, as a duty.** In other words, they don't lose their life for their unfaithfulness, but they will not be on the throne, with the faithful of the church.

Remember that the great company will be before the throne, and that **only the 144,000 will be found on the throne**, and so this description fits very well with the Rev account.

Rev 3:21 To him that overcometh will I grant to sit with me in my throne, even as I also overcame, and am set down with my Father in his throne.

Faithful Levites

Ezekiel also gives us a description of the faithful Levites, (the sons of Zadok) and how they would be able to come before God, or be on the throne, just as the Rev account shows. The word Zadok is Strong's word #6659, which is taken from #6663, which means "be just, rightness or lawful". This meaning fits very well with the character of the 144,000! Ezekiel tells us that only they would be able to come before God, which is what we see in Rev! *Rev 14:1 Then I looked, and there before me was the Lamb, standing on Mount Zion, and with him 144,000 who had his name and his Father's name written on their foreheads. (NIV)*

FOUR LIVING CREATURES

We think that the 4 living creatures, are representative of the four attributes that help define what God and his plans are like. We find these in Psalms. *Ps 89:13 Thou hast a strong arm; Thy hand is mighty, Thy right hand is exalted. 14 Righteousness and justice are the foundation of Thy throne; loving kindness and truth go before Thee. (NAS)*

The words "strong" and "mighty", describe Gods power. "Righteousness" and "justice", are obviously pointing to justice. "Loving kindness" show us that God is love, and the "truth" that goes before him, represents his word and we know that in his word, is to be found all wisdom!

These four attributes not only make up God's character and support his throne, but we should expect to see them exemplified in his plan. If we do not, we should ask ourselves if we are believing in the correct plan. Only the Divine Plan of the ages, as found

in "the Studies in the Scriptures", meets those requirements.

We see in Ezekiel 1:25-26, that these 4 creatures actually are under and supporting Gods throne and therefore agreeing with the definition found in Psalms .

25 And there was a voice from the firmament that was over their heads, when they stood, and had let down their wings.

26 And above the firmament that was over their heads was the likeness of a throne, as the appearance of a sapphire stone: and upon the likeness of the throne was the likeness as the appearance of a man above upon it.(KJV)

If these four attributes belong to God, this is telling us that everything that he does, is governed by these four attributes. He does not just pick out one attribute such as justice and use it by itself, but he uses all four of these in perfect balance with each other. If we were to look at only justice when we examined God's plan, we would be making the same mistake that some do who only see a harsh judging God. **If we look far enough we will see that judgment is counter balanced by love.**

On the other hand, we should not look at only love, as some do, saying that it doesn't matter what we do, since God is love and he will forgive us no matter what. Remember love is counter balanced by justice.

If the 24 elders are representative of God's old testament word and we see that the 4 living creatures represent the wisdom, justice, love and power that are found in the scriptures and we should then recognize that God's word is governed and controlled by these four attributes.

In Rev, we find the 4 creatures, together with the 24 elders, most of the time. **In other words, the 4 attributes, wisdom, justice, love, and power are found intertwined throughout the scriptures. The scriptures will not say anything that conflicts with these principles, but will be found in perfect balance with all of them.** These four attributes or creatures all work together, in harmony to bring God's plan to a perfect completion!

Four Biblical Theme's

God could not go against the just sentence that was brought against the human race in the garden, without something being done to satisfy justice. Through love, he could use wisdom and power, to provide a plan with a ransom, by which he can restore man back to the life rights that he had lost in the garden. If that's the case, we should see those attributes displayed in everything that he does, even in the chronology that makes up his plan!

(1) Judgment or Justice

We will see that each of the three patterns we are going to consider in this booklet, has its own Biblical theme.

The 1845 year pattern, which we we considered first, deals with

justice or judgment. We see this very plainly, in that Ezekiel gives a message of judgment, in chapters 1-10, covering the visions of the Cherubs. See the special section of explanation, on page 38, for an explanation of these dates and the chronology associated with them.

(2) Wisdom

We also see wisdom in that same 1845 year pattern, in that God was wise enough to provide a means in by which mankind can be re-tested, after they have been restored to perfection, at the end of the millennium. They should be able to pass that test, since they will have the experience of sin and death, and will know better because of the experience that they just had. Adam, while perfect, was not able to pass the test, because he had no experience with sin and death.

Looking in the tenth and eleventh chapter of Ezekiel, we see that the vision has changed from chapter one. We find that the Ox has changed to a Cherub, which shows that Christ has paid the price and has been changed to a heavenly being. This price was the means by which it will be made possible, for all to have a new testing at the end of the age.

In Ezk. 11:17-20, God tells us that he is going to restore Israel to their land, after he has finished punishing them. This is an intimation or picture of the Divine plan, by which first literal Israel, and then the world, will be restored and given a chance, to pass a second test at the end of the millennium.

Israel is used as a type or example, in that the things that happen to them, are examples unto us and to what is going to happen with the world. The world will be adopted as aliens, into the nation of Israel in the next age. In this age, the church has taken Israel's place, because of their unfaithfulness.

1 Cor 10:11 These things happened to them as examples and were written down as warnings for us, on whom the fulfillment of the ages has come. (NIV)

After having received experience with sin and death, they will be given a new chance to be tested in the little season, and most will then be able to pass it, because of the experience they have gained. Adam and Eve had no experience with sin and death, and that was why they failed the test. This similar to what we see, when you tell a child not to touch a hot stove, but he does anyway, because he doesn't know how painful it will be. He of course has no trouble staying away from the stove, a second time, after burning himself.

Coals of Fire

We see coals of fire on the altar in Ezekiel 10:6-7, which in symbol, represent the ransom doctrine. See also Rev 8:3-5. The ransom is the price that Christ paid for all men, not just a few, as some would like us to think. Besides the great love that it took, we see that God has great wisdom, in that he has designed a plan, that will restore all who are willing, including literal Israel, back into harmony with him.

(Rom 5:17-19) 17 If, because of one man's trespass, death reigned through that one man, much more will those who receive the abundance of grace and the free gift of righteousness reign in life

through the one man Jesus Christ. 18 Then as one man's trespass led to condemnation for all men, so one man's act of righteousness leads to acquittal and life for all men. 19 For as by one man's disobedience many were made sinners, so by one man's obedience many will be made righteous.

The New Temple

Later in Ezekiel, chapter 40 onward, we see the vision of the temple complex, which pictures the salvation of the millennial age. The temple is a picture of the completed church, and how it relates to the new Jerusalem, (Gods kingdom) that we are shown in Revelation . The city New Jerusalem, represent in symbol, Gods government coming to earth, to bless and restore mankind. This is during the millennial age, when both Christ and the completed church, will rule over the earth. No more wars or corrupt governments will be allowed. This does not mean that there will be no local government allowed, but any that does exist, has to work in harmony with the kingdom.

(Rev 21:2-5) 2 And I John saw the holy city, new Jerusalem, coming down from God out of heaven, prepared as a bride adorned for her husband.

3 And I heard a great voice out of heaven saying, Behold, the tabernacle of God is with men, and he will dwell with them, and they shall be his people, and God himself shall be with them, and be their God.

4 And God shall wipe away all tears from their eyes; and there shall be no more death, neither sorrow, nor crying, neither shall there be any more pain: for the former things are passed away.

5 And he that sat upon the throne said, Behold, I make all things new. And he said unto me, Write: for these words are true and faithful.

(3) Power or Right to Rule

In regard to power and the right to rule, we have seen it represented in the Revelation throne scene, of chapter 4-5, that we just considered in this book. The Lord God is seen on his throne, as well as the lamb of God, (Jesus), who was slain for us. The throne scene shows us both God's and Christ's, power or dominion. As we know, this is an important theme, in both Rev. and Daniel. Both books show the coming kingdom, and the judgment of the false system, which instituted a counterfeit reign in the dark ages.

We find the 1260 years mentioned in Rev. and in Daniel, in several forms, such as 42 months, 3.5 times, and 1260 days. The 3.5 times, are 3.5 times 360 or again 1260 years. This is the span of time that the false system was to rule and oppress the saints. As we have already mentioned, its historically confirmed that it did exactly that, from 539 AD to 1799 AD. See the special section of explanation, on page 38, for an explanation of these dates and the chronology associated with them.

Just as an interesting note, the ones that claim there is a future literal 3.5 years, use these same scriptures and numbers. In other words, by the simple mistake of using this as a literal number, the actual guilty party, Papacy is overlooked, and we are waiting for some future literal man of sin to come, who will never show up, because he has already been and is still here!

(4) Love

The 2500 year Jubilee pattern, we will consider after this, will show us the restitution, that Gods love brings. As we will see later, the vision of the Seraphim in Isaiah, will be represented by the 2500 year pattern. See the special section of explanation, on page 38, for an explanation of these dates and the chronology associated with them.

Biblical Themes in the Chronology

What we see, is that the book in which each individual chronology type and theme is found (1845, 1260, 2520, 2500), matches the prophecy in the area of the bible that it's found in.

The 1845 years, which is found in Ezekiel's vision of the Cherubim, is justice or judgment but it also includes the wisdom or promise of another trial or testing, after mankind is restored.

The 1260 and 2520, points us to who has the right to rule. The book of Rev. deals with the topic of the false reign of the harlot, and the beast, 539 AD - 1799 AD, and their eventual defeat after 1914 AD. Towards the end of Rev., we see the rightful government, Christ and the church, come down to the earth, to rule and bless the world, in the millennial age.

Restitution of All Things

And last but not least, we see that the 2500 yr. jubilee, points to restitution of all things and again, that is a major theme found in the book of Isaiah, (See also Acts 3:19-21)! Everything that was lost by Adam, will be restored by Christ, in the period of restoration, in the millennial age.

30, 33.5 and Christ

We have included a couple of pages, 36-37, in this booklet, where we have combined all three chronology patterns together, (1845, 1260 and 2520, 2500). We see that it took great wisdom, to design a plan with such intricacy and to have it work together, to accomplish Gods plan. **That composite pattern, when seen all at once, represents all of the above attributes, wisdom, justice, love, and power, working together, as a harmonious whole!**

In that pattern, we see that there are a couple sets of spaces between the circles, that are 30 years, and 33.5 years in length. **This shows us that God has based his plan exclusively on Christ, since 30 is the age at which he began his ministry, and 33.5 was when he was crucified.** If these patterns are accidental, how could such significant numbers keep coming up?

25 inch Cubits in the Bible

The principle of 25 inches or years per cubit, that we saw in the tabernacle, will be found to apply to the rest of the cubits in the Bible, with similar results. We will find that wherever God gave the cubit dimensions in the Bible, it has some meaning or relationship to his plan or chronology.

We have included several pages, that cover almost all of the cubits found in the Bible. The buildings and furniture etc., show us the plan of God, being constructed of cubits, that translate into 1000, 2500, 6000, 7000, 100 etc.! We will see the same basic numbers, repeated throughout the entire bible, which shows that God has had a hand in writing it, and not just men, as is claimed.

BIRTH OF
CHRIST
1.25 BC

THE TABERNACLE OF THE WILDERNESS

SECOND
ADAMS
DAY
1873.75 AD

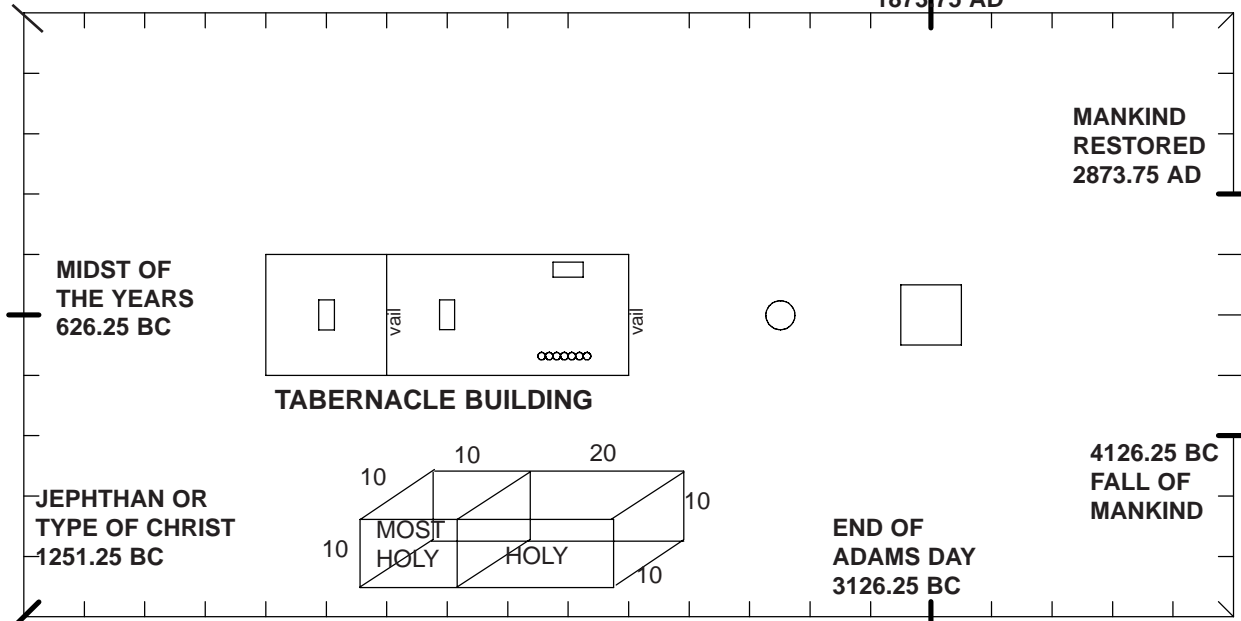

The concept for this tabernacle chart, originally came from a reprint article, (6435-36), that was published after Pastor Charles Russell died.

The dates on this chart, are similar to the 1845 and the 1260, 2520 year patterns, in that they are also symmetrical about the midst of the years, (626.25 BC). This pattern has only 7 important dates on it.

A Symbolic 25 Inch Cubit

The dates on this chart, are derived from the symbolic 25 inch cubit, that can be used to unlock the time features of God's plan. There were originally, at least two different cubits used in Biblical times. The first was 18 inches and the second was 21-22 inches. The 25 inch cubit, is the one that is described in Ezk 40:5, as being about a hands breadth larger than normal, (about 3 inches).

7000 Years Around the Tabernacle!

For example, the tabernacle is 100 by 50 cubits. From each gate post, to each corner, is 15 cubits. The total distance from the corner post of the first gate, all the way around the tabernacle, and back to the other gate post, is 280 cubits, (15+100+50+100+15 = 280). At 25 years per cubit, this is 25 x 280 or 7000 years!

The Gate Posts Are the Dates

(1) If we call the first gate post the fall of Adam, the date for that post is 4126.25 BC.

(2) Going clockwise from there, the next or second important date that we arrive at, that corresponds to a post in the fence, is 3126.25 BC or the end of Adams first day. This was the 1000 yr day, within which Adam was to

die, at the age of 930 yrs.

(3) The original reprint article, placed the third date on the corner with a Judge named Jair. This application has since had some doubt cast upon it, because this time period falls in the 450 yr. space of the Judges, which is uncertain as to its exact time make up.

The other possibility is a Judge named Jephthah, (Judges 12:6)? Jephthah and his daughter make an excellent picture of our Lord and the church, since he consecrates her to the Lord, as a virgin for life. We think that Jephthah, is the correct choice for this corner, but we have to admit uncertainty, because this is the period of Judges, which is bridged only by Paul's statement, regarding the 450 years. **The choice should be a type of Christ, since he is on the opposite corner from Christ's birth!**

(4) The fourth date is 626.25 BC, the midst of the years, which is the same central date, on the 1845 and 1260-2520 charts.

(5) The fifth date, is 1.25 BC, Oct, 2 BC, confirming the date of our Lords birth!

(6) The sixth date, is three-fourth of the way down the side, and is 1873.75 AD. This is the date of our Lords second presence. He is the second Adam, who is going to restore all back to perfection by the end of the 1000.

(7) At the seventh and last date, we arrive back at the other gate post, and this 2873.75 AD, exactly 7000 years after we started out. This completes the cycle, shows that what Adam lost in the garden, will be restored exactly 7000 years later, at the end of the seventh day!

5*4 = 20 20*2 = 40 YEARS

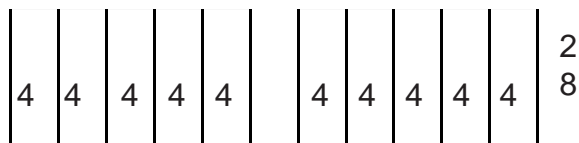

LINEN CURTAINS EZ 26:1-6, 30:8-10

Linen Curtains

Total width of the ten curtains, is 40 cubits (40 x 25 = 1000).

Each curtain is 28 cubits long, and there are 10 curtains. Total length of all the curtains is 10 x 28 = 280 cubits, (280 x 25 = 7000 years).

Five curtains = (5 x 28 cu = 140 cu) (140 x 25 = 3500 yrs).

Curtains of Goat Hair

The curtains of goat hair, were different from the 10 linen cur-

5*4 = 20 4*6 = 24 24+20= 44 PAGE 31

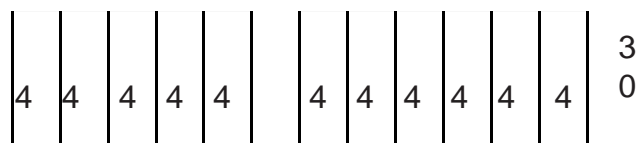

CURTAINS OF GOAT HAIR EX 26:7-13,30:14-18

tains, in that there were 11 curtains and they were 30 cubits in length, instead of 28. The eleventh curtain was folded in half, in the front of the tabernacle. Without the eleventh curtain, the total was 40 cubits and again 40 x 25 = 1000.

The eleventh curtain that was folded in half, was 4 cubits wide, (4 x 25 = 100 years or Isaiah 65:20).

Another possible application of the folded curtain, is that each folded half is 2 cubits apiece, (2 cu x 25 = 50) (Jubilee)

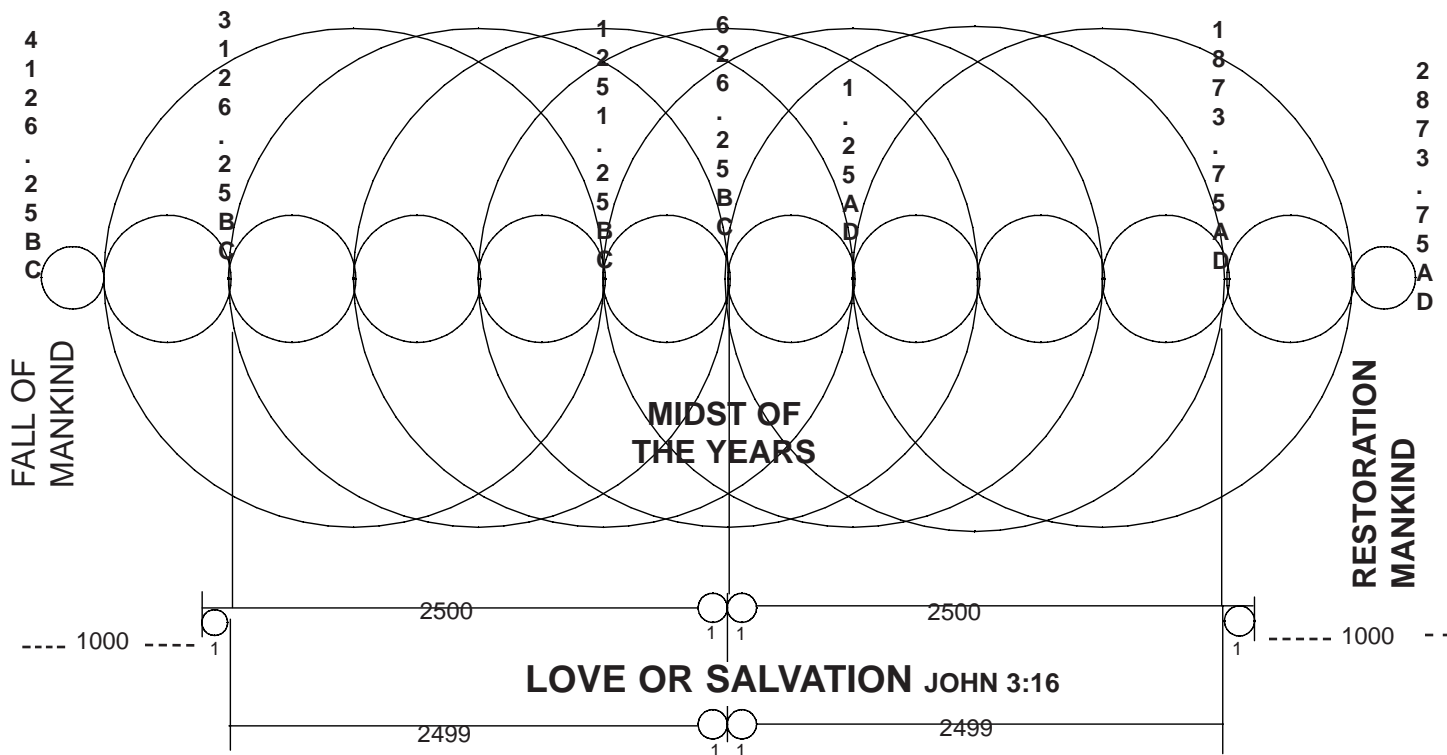

The Circles Come from the Tabernacle Post Locations

If we redraw the dates that we find around the tabernacle fence, and place them in a repeating circular pattern like in the 1845 and the 1260-2520 year chart, this is what results. This circular line diagram, shows that the Jubilee cycle, is also part of a pattern, that is symmetrical about the midst of the years.

What Adam lost, is being pointed out, as what will be restored by the Jubilee, in the kingdom. Remember that Jesus said "For the son of man has come to restore what was lost Matt 18:11". The first man Adam, forfeited his life during his 1000 yr day, but the second Adam (Christ), will use his day to give life to all mankind, who will accept it! God through his love, made restitution possible, and for that reason, the attribute of love, is shown by this chart. See "the 2nd volume, "Studies in the scriptures", chapter 6, The earths great Jubilee.

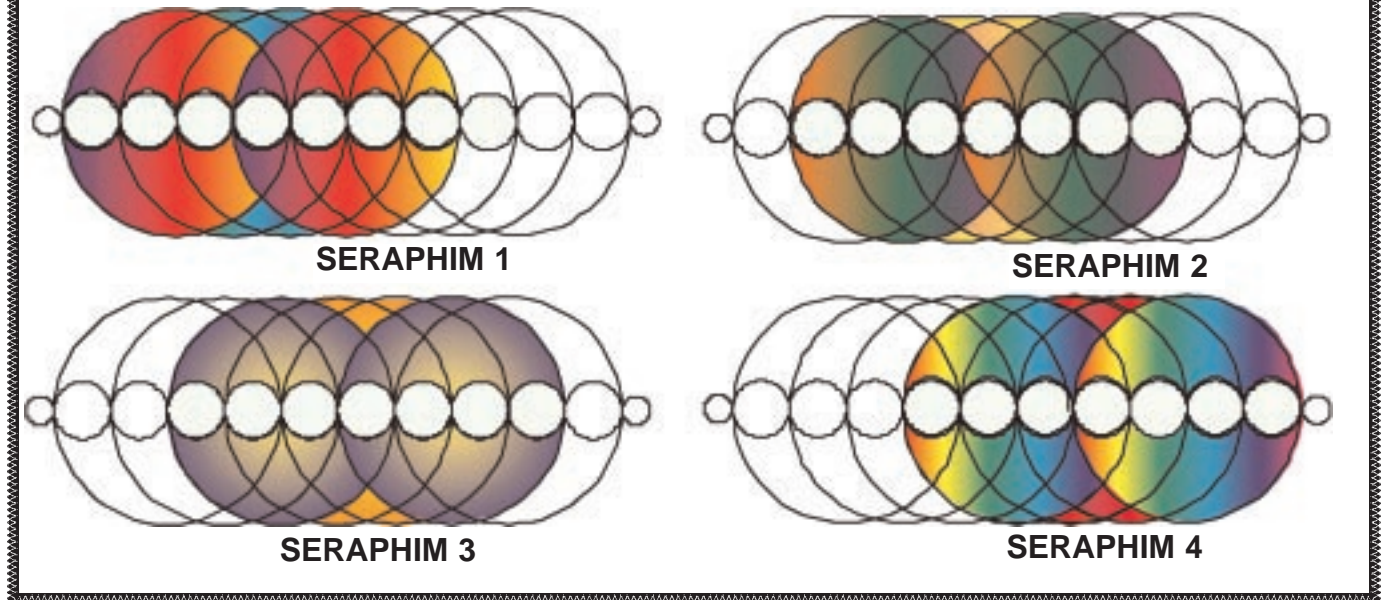

Isa 6:2 Above him were seraphs, each with six wings: With two wings they covered their faces, with two they covered their feet, and with two they were flying.

4 Seraphim of Isaiah 6

The 4 Seraphim above, are similar to the ones found in the Ezekiel account, except that these have 6 wings apiece. We assume 4 Seraphim, because the other visions have four.

The wings are similar to Ezekiel's vision, but because this one has seven circles of 2500 years, and the Ezekiel account, only had 6 circles of 1845 years, we wind up with an extra pair of wings tucked in behind the other two pair, making six, just as Isaiah described. We have shaded these in differently, to make them easier to see.

The 2500 Jubilee Picture

Even though the anti-typical Jubilee, started in Oct 1874, and will complete its work in Oct 2874, this does not mean the full benefits of restitution were here in 1874. The world has only received fore-gleamings of the full benefits, that are due later. The only resurrection to life has been to the church, (1878 AD), and not to the world. See the special explanation section starting on page 38, regarding the Jubilee and restitution.

If we look at what happened in the actual jubilee year, the beginning of this year, was started by blowing the feast of trumpets only in the temple, on the first of the month Tishri. No one received any release, until the 10 th of Tishri, when the Jubilee trumpet was blown throughout the entire land. Then the people were gathered together and a release was proclaimed to all, (Lev 25:28-55).

The 1874 AD Jubilee Message

The same thing has been true at this end of the age, in that the Jubilee trumpet has been blowing since 1874, and the church has been proclaiming the message of the kingdom to all who will hear it. Its not possible for the world to get their full release,

until they are in the kingdom, and then not completely until the end of the 1000 years. Full restitution to the world, will not come until the church is completed, and then the world will be restored back to Adamic perfection and health, by the end of the kingdom. The trumpet is blown on the 10 th of the month, and ten in the Bible, shows earthly completeness.

Coals of Fire Represent Ransom

The coals of fire, off the altar, mentioned in Isaiah 6:6-7, are the same coals of fire, we see in Ezekiel 10:2, 6-7, Rev 8:5, and they represent the ransom doctrine. In Isaiah's case, it cleansed him from his iniquity, but in Ezekiel's and the Rev case, the coals were cast over the city for judgment.

For anyone that is in opposition to God's plan and the ransom, such as the false church system, these coals are part of a destructive process, that will cleanse the world of its iniquity and sin. All things that are not built on the foundation of Christ, will not be able to stand, and will be completely removed, 1 Cor 3:11-15, Heb12:25-29.

The prophet says in Hab 3:2, that God's work fills him with fear. **This word fear is Strong's word #3372, which means reverence.** Reverence means to regard with high respect or awe, and after seeing his plan reflected in these patterns, we can echo the prophets sentiments, in that God's work does fill us with great reverence and awe!

God is Answering Hab Prayer

There is no doubt in our our mind, that God is answering Habakkuk's prayer, to a greater extent, than even he could have imagined! The time will soon come, when all those who are in their graves will hear his voice and will be restored to health and life (John 5:25).

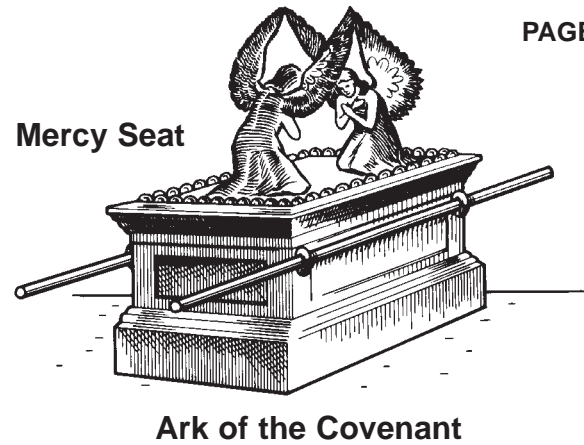
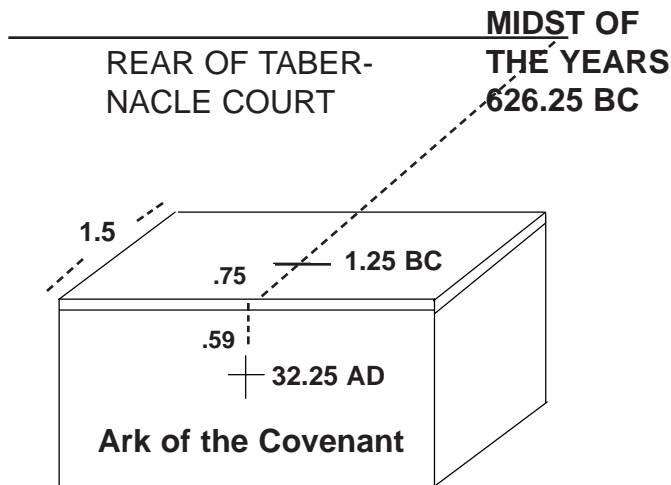

LEVITICUS 16:14 And he shall take of the blood of the bullock, and sprinkle it with his finger upon the mercy seat eastward; and before the mercy seat shall he sprinkle of the blood with his finger seven times. **15** Then shall he kill the goat of the sin offering, that is for the people, and bring his blood within the veil, and do with that blood as he did with the blood of the bullock, and sprinkle it upon the mercy seat, and before the mercy seat:

The Birth of Our Lord

Contrary to common thought, we believe that our Lord was born 1.25 BC or Oct 2 BC, and he was crucified 32.25 Ad or April of the year 33 AD. Using those dates, if you measure from the back of the tabernacle fence, at the midst of the years, (626.25 BC), to the center of the mercy seat, you will find that the distance is 25 cubits. Converting this into years, at 25 years per cubit, we get 625 years. Adding 625 years to 626.25 BC, gives you 1.25 BC. **His birth date therefore falls exactly between the Cherubs, in the center of the mercy seat!** This confirms that 1.25 BC, is the correct date for our Lords birth.

Our Lords Ministry, Reaches to the Eastern Face

If we take the time that our Lord spent on the earth, (33.5 years), and we convert this into cubits, we get 1.34 cubits, (33.5 divided by 25 = 1.34 cubits). Extending a line this length, from the birth of Christ, on the center of the mercy seat, across the top and then down to the eastern face of the ark, 1.34 cubits, brings you to April of 33 AD. This would then be .75 cu across the mercy seat, and down the face of the ark .59 cu.

The eastern side of the ark, is the side that you would face upon coming into the most holy. Its very likely that the high priest sprinkled the blood, starting on top of the mercy seat, and then towards the front, in an eastward direction. The path of the cubits, and the blood, both point to where our Lord Jesus laid down his entire life for us.

Seven Times For the Church

To sprinkle the blood 7 times before the mercy seat, was to sprinkle it on the eastern front of the ark, where it could run

down to the earth. That this is on the face of the ark, and not directly on the ground, is shown by the meaning of the word "upon", (Strong's word # 6440), which means face, forefront, front, etc., thus implying the front face of the mercy seat. That this sprinkling was done 7 times, shows the completeness of Christ's sacrifice, for the church. The blood of the bullock was paid for himself and his house hold, at the first advent.

Seven Times For the World

That the goat was also sprinkled seven times, seems to show that when the church is complete, nothing more will be needed for the people of the world.

That this bullock was for himself, as well as for his household, is at first puzzling, since Christ was perfect and did not need ransoming. If we remember that Christ needed to be tested and to prove himself to the heavenly Father, we can then see that offering the bullock for himself, in symbol showed that he had done everything faithfully and without fail. The household, of course represents the church, who needed to be covered for their imperfections and who also need to prove themselves.

The world is waiting, for the time that all the members will have become part of the body of Christ. At that time the blood will be applied, for "all" the people (the goats blood Lev 16:15-16).

The Cherubs Fly to Bless the World

Once the blood of the goat is applied, the two Cherubs will no longer be blocking the way to life, but will then be able to fly forth to bless all the world. In the next age, the rest of the world will be grafted into the nation of Israel, and all will receive the blessings. "Then **all** Israel shall be saved, as it says" (Rom 11:26)!

BRAZEN ALTER

EX 27:1 38:1

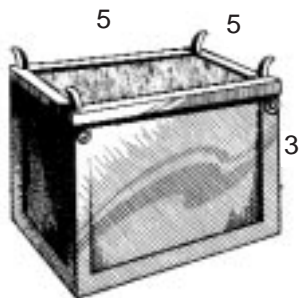

TOP 20
 BOT 20
 END 6
 END 6

 52

MERCY SEAT

EX 25:17 37:6



2.5
 2.5
 1.5

 1.5
 8

TABLE OF SHOWBREAD

EX 25:23, 37:10

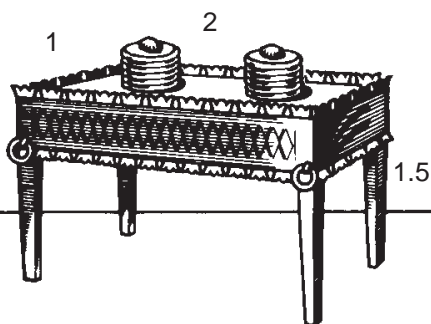

TOP 6
 BOT 6
 1.5
 1.5
 1.5

 1.5
 18

ARK OF THE COVENANT

EX 25:10, 37:1

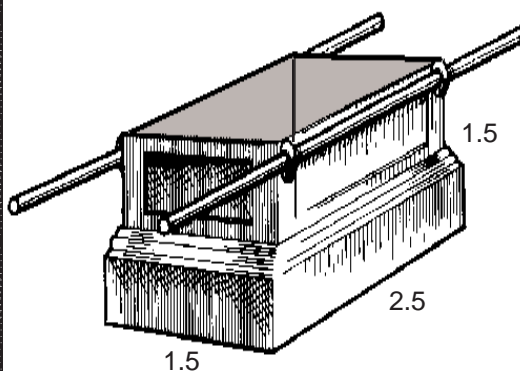

TOP 8
 BOT 8
 1.5
 1.5
 1.5

 1.5
 22

THE TABLE OF SHEW-BREAD

Total cubits above

Altar	52
Mercy Seat	8
Table of	
Show Bread	18
Ark Cov	22
	<hr/>
	100

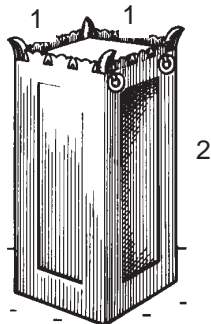

The 4 verticals are 2 cubits apiece.
 The top is 4 cubits as is the bottom.

Two verticals of one face = 4 cu.
 4 sides of top = 4 cu
 4 sides of bottom = 4 cu

$4 \times 25 = 100 \text{ years}$

This is the 100 years of Isaiah 65:20

2500 Jubilee in the Furniture

If we add up all the dimensions of the brazen altar, the ark of the covenant, the mercy seat, and the table of show bread, we will find that they all total up to 100 cubits, ($25 \times 100 = 2500 \text{ years or the Jubilee}$).

Dimensions of the Incense Altar = 100

The only piece of furniture not used in that calculation, is the incense altar. Taking the incense altar by itself, we find that the top and the bottom, add up to 4 cubits. Any two verticals add up to 4 cubits. $4 \times 25 = 100 \text{ cubits or the 100 years of Isaiah 65:20}$.

The Brazen Altar = 1000

If we take the top and the bottom of the brazen altar, the dimensions add up to 40 cubits, $40 \times 25 = 1000 \text{ yrs}$. Looking at these numbers, we can see that the eventual restitution of all mankind, is being shown in the dimensions of the tabernacle furniture, when its looked at together, Acts 3:19

We find represented in the tabernacle furniture, the 2500 Jubilee cycle, pointing to the restitution of all things, the 1000 year day in which mankind will be restored, and the fact that all will have at least 100 yrs to hear and to accept the kingdom.

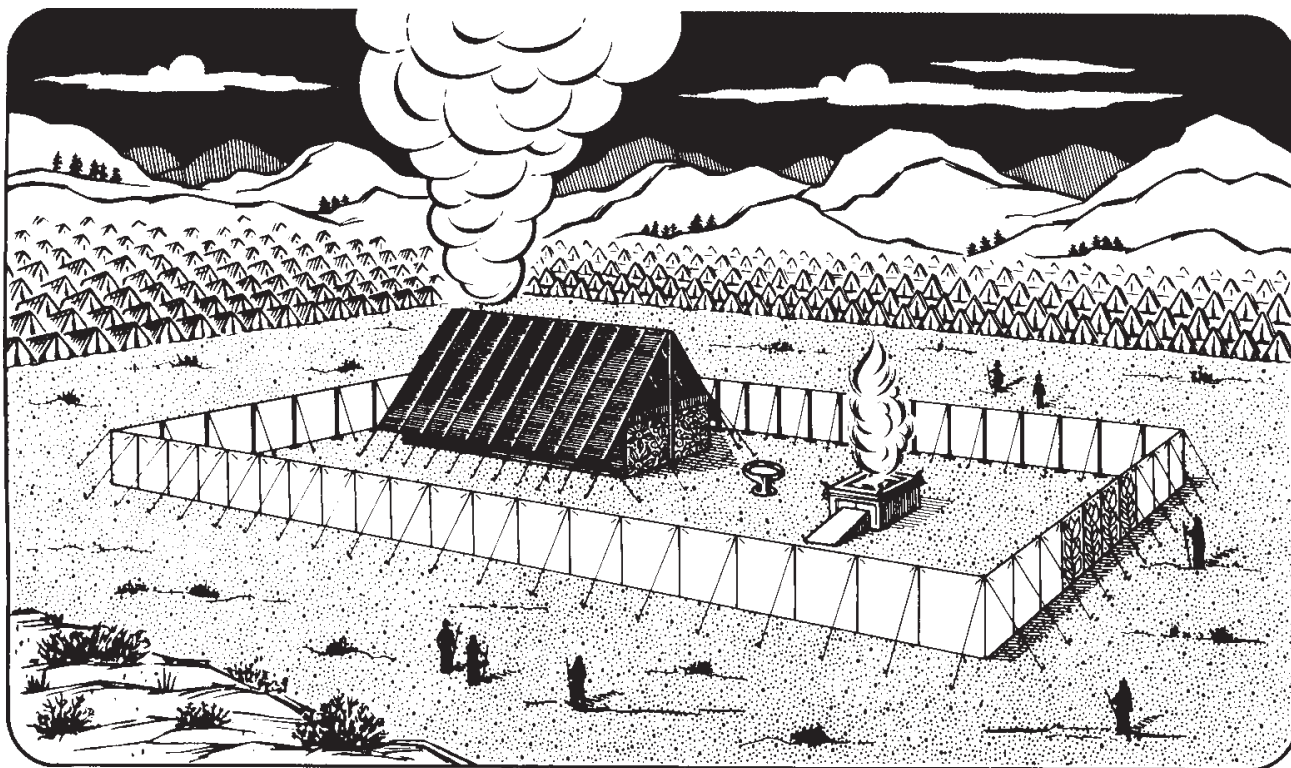

Dimensions of the Most Holy = 1000 yr

The dimensions of any perimeter of the most holy are $10+10+10+10 = 40$ which represents 1000 years ($40 \times 25 = 1000$). The sum of any two lengths of a side wall of the holy, are $20+20 = 40$.

The Altar Adds up to 1000 yr

The perimeter of the top and the bottom of the altar adds up to 40 cubits $40 \times 25 = 1000$ yrs.

The sum of the length of the first vail of the holy plus the ceiling and the second vail of the most holy makes 40 ($10+20+10$). $40 \times 25 = 1000$ yrs.

Dimensions of Most Holy = 6000 yr

All of the dimensions of the 6 walls of the most holy taken together add up to 6×40 or 240 cubits. ($240 \times 25 = 6000$ years). This is taking the measurements of each wall as if they were separate panels with 4 sides apiece.

If we add the line dimensions of the holy and most holy together, taking them as separate panels, we get 40 for an end + 80 for the lengths of the holy, 40 for the front wall of the most holy, 40 for the lengths of the most holy and 40 for the back wall ($40+80+40+40+40 = 240$) ($240 \times 25 = 6000$ yrs.

The 2500 Year Jubilee is Represented

If you measure from the midst of the years at the center of the back of the tabernacle straight to the front gate without

going around the outside you get 100 cubits ($100 \times 25 = 2500$). Not only is this the 2500 yrs of the Jubilee but if you add this number to the date at the center of the back of the tabernacle fence you get the date of our Lords second presence ($626.25 \text{ BC} + 2500 = 1873.75 \text{ AD}$).

A Year Per Cubit?

For example, we could get some interesting numbers at a year per cubit if we look at the dimensions of the buildings and the furniture, but again to save space, we are not going to do that except for the following example.

The altar in the court which represents Christ's sacrifice has some interesting diagonals. See the diagram on the next page. It was $5 \times 5 \times 3$. **The diagonals of the top are almost exactly 7 cubits (7.071).** At a year per cubit a half of this length is 3.5 yrs or the time our Lord spent in his ministry. Seven is the length of the last week of the 70 weeks Dan 9:24-27.

In some places its possible to mix together both methods of a yr. per cubit and 25 years per cubit but we are only going to do this where its necessary to gain an important lesson.

More to the Story!

In the following pages we do not claim to have fully explained or even found all of the features associated with the different chronological cycles or cubits. God has designed into his plan much more complexity and detail than we can put into these pages.

We have marked the position of all 24 dates from the three charts, so that they can be viewed together. **There are 12 dates that are symmetrical to each other about the center of the years, (shaded numbers).** There are 3 midpoint dates at the center of the years, even though only two patterns go through the center. If we subtract the 12 symmetrical dates, we have 12 dates left that belong to the original 24. **These 12 belong to a group that are not symmetrical to any others.** To get this result, we count one of the 1874 dates as symmetrical and one as not, since there is only one date on the other side of the chart to balance it. **Together we have 12 symmetrical dates, 12 non-symmetrical dates!** We only get this result if we accept the 19 year Joshua change! The non symmetrical are the clear boxes and the shaded are the symmetrical.

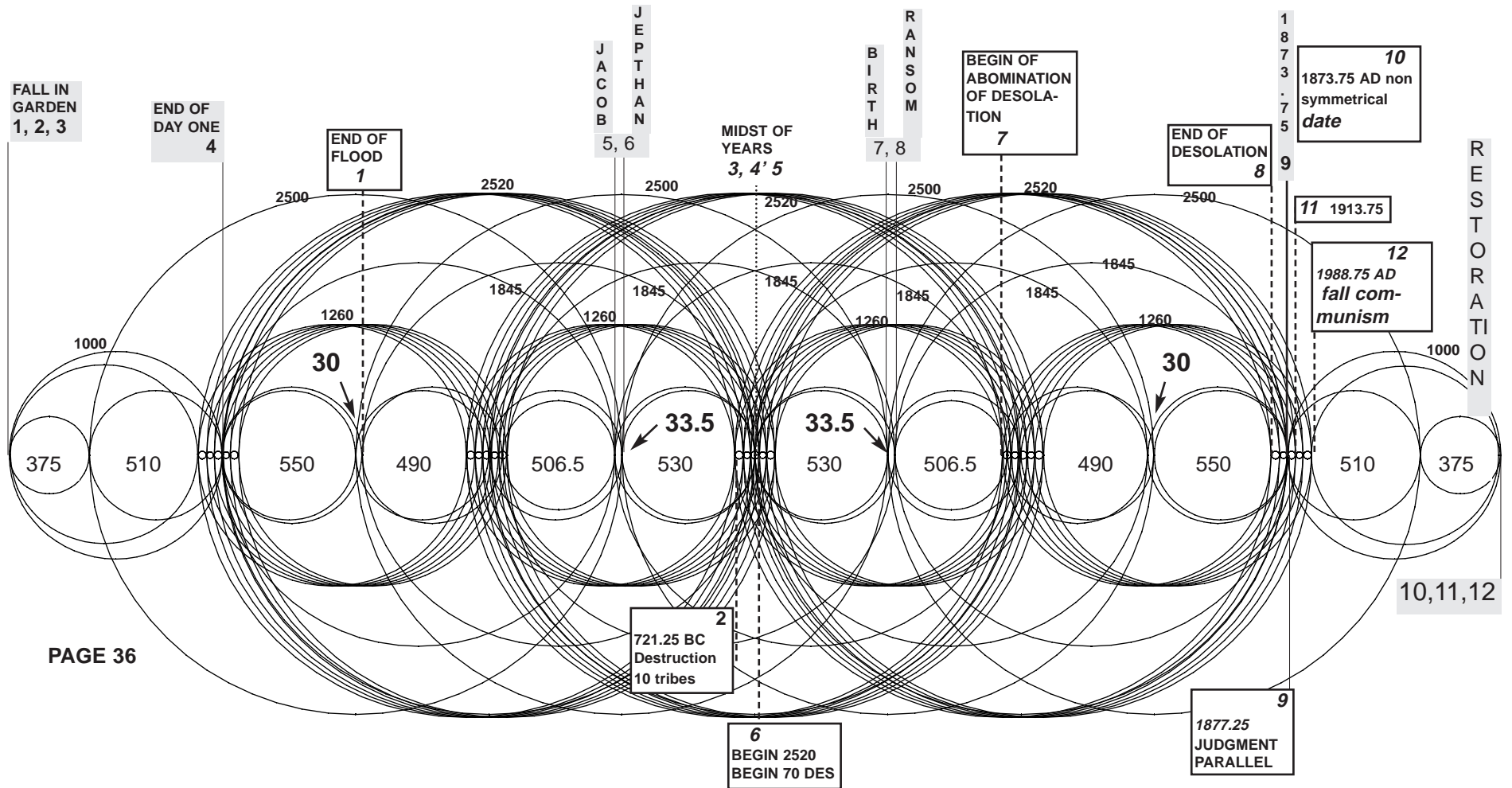

The above diagram is drawn to scale so that the exact relationship of the three sets of chronological circles of 1845, 1260, 2520 and the 2500 year circles to each other can be seen. We can see from this diagram that all of the chronology circles meet at nodes and are not randomly scattered. The small spaces between the 550 and the 490 spaces are 30 years apiece and the space between the 506.5 and the 530 spaces are 33.5 years. Our Lord was 30 years old at the start of his ministry. The 490 space is the number of days in the 70 weeks of Daniel which also points to the time of our Lords ministry. The 33.5 year space on the right hand side of the chart is created by the actual date of our Lords birth and the date of his crucifixion!

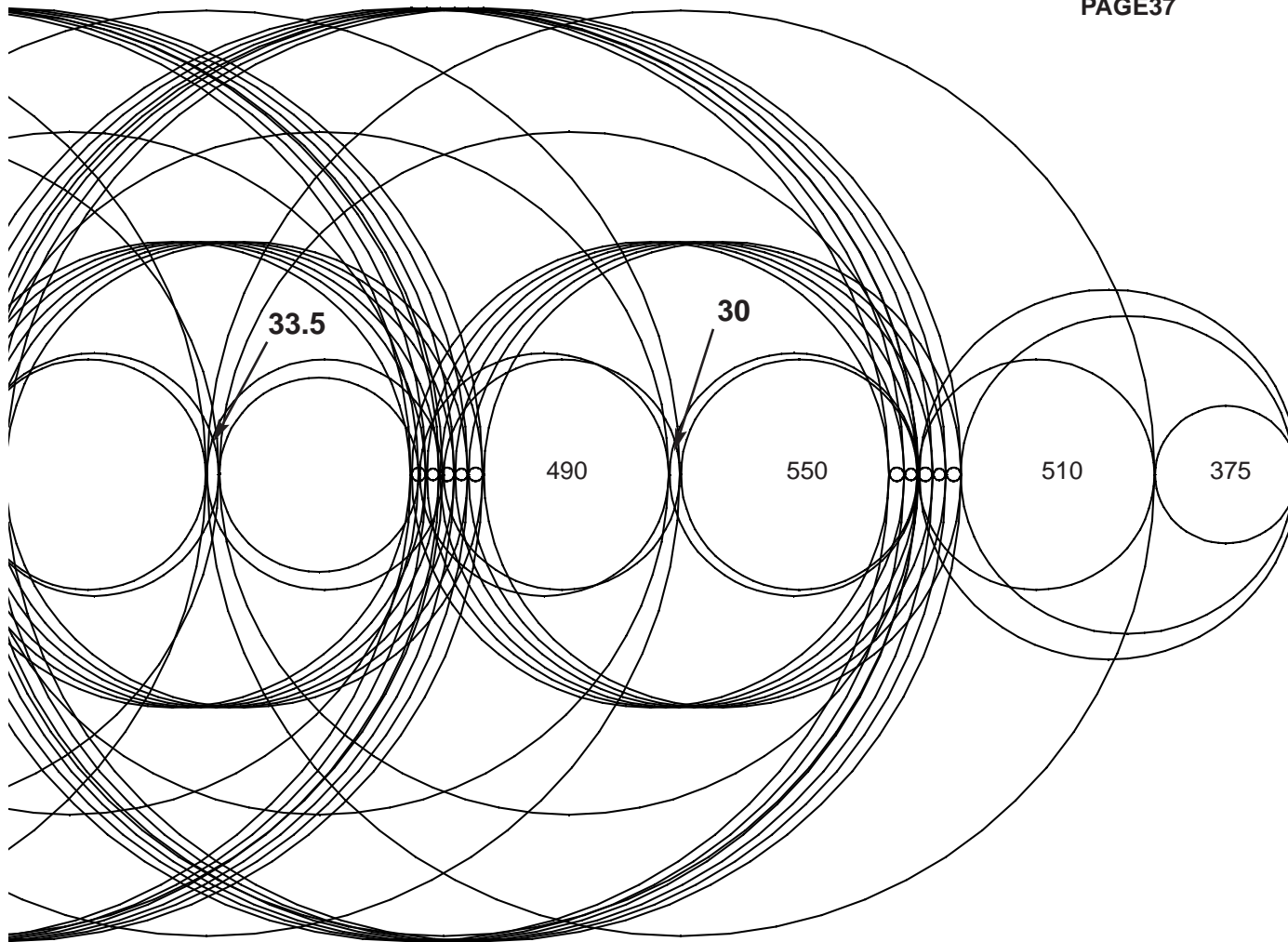

If we add each group of 40-35-40-35-40 circles we get a total of 190 years for each set. Adding these together in the 5 places that they appear and all the rest of the years including the 30 and 33.5 spaces comes to a total of 7000 years for the complete chart. For example $375 + 510 + 190 + 550 + 30 + 490 + 190 + 506.5 + 33.5 + 530 + 95 = 3500$ which is to the center or midst of the years. $2 \times 3500 = 7000!$ Note "one half of the five center circles of 190 = 95 yrs.

That this intricate pattern fits together so well is not an accident considering its author. Each chart by itself would be an impossible task for us to construct given the dates that each has to intersect! To view all 3 sets of chronology together generates a symmetrical pattern which includes two sets of spaces of 30 and 33.5 years.

The 30 and 33.5 year gaps point at Jesus as the means by which God is going to restore the world back to what Adam lost! From this pattern we see the complete control over his plan that God has had from the beginning and will have until the end! The only date left on the pattern, of the 24, that has not been fulfilled is the 2874 AD date !

Discussing God's Plan, and its Chronology Expectations

We intend, as time goes on, to add more explanation to this section, to help those who haven't studied this topic before. This is a difficult task, since each reader knows, or does not know, things that we can have no way of predicting. We also have to consider that the reader may have preconceived ideas on some things, that may not agree with what we are presenting. This increases the difficulty, since we have only limited space to present evidence for our view.

If you see that there is something to this booklet after having gotten this far and after having read this section, we have a recommendation for you. Since these chronology patterns confirm the Divine Plan of the ages, as brought forth in volume 1 of the "Divine Plan of the Ages", we recommend that it should also be read and understood, in order to gain the most benefit from the study. For those who do not have the above volumes, they may be ordered from, "*The Bible Student congregation of New Brunswick, P.O. box 144, Edison, NJ 08818-0144 USA*". Another address is, "*Book Republishing Committee, 1648 Charles Drive, Glendale Heights, IL 60139 (708-687-5450)*". The price is very low for a set of six, hard bound books, (less than \$20 at the time of this writing). Contact the above addresses for the current price.

We would recommend the reading of at least the first three of these, as a bare minimum to help in the understanding of this material. All of them will be found to be very revealing in regard to gaining a better understanding of what is Gods plan and intent, both for the church and the world. Do not just read them by themselves, but examine them with your bible in hand!

1 Jn 4:1 Dearly loved friends, don't always believe everything you hear just because someone says it is a message from God: test it first to see if it really is. For there are many false teachers around, (1Thes 5:20-21) 20 Do not scoff at those who prophesy, 21 but test everything that is said to be sure it is true, and if it is, then accept it.

An Excellent Witness to Gods Plan!

The earlier editions of this booklet, were intended to be supplemental material regarding chronology, especially for Bible Students who had already studied the above volumes. We have decided to try to make this book available to a wider audience. Because of the complicated nature of the material, that is not going to be an easy task, so we pray that we will be able to accomplish this for the glory of God. This edition is our first try at doing this, so we hope that we can at least convince the reader that there is something wonderful going on here, even if they don't fully understand it. We pray that God will supply the parts that we are lacking in our explanation, for those who are truly searching after him.

This booklet, has several amazing chronology patterns, never seen before, which help to prove what God's plan is, and that the chronology associated with it, is correct. As we have studied the chronology patterns in this booklet, we have gradually realized that they would make a very compelling witness to Gods plan. For that reason we have included more material in this edition, this section for example, which discusses the Bible Student chronology and its relationship to the Divine Plan.

In the earlier sections of the book, we have see graphically represented Cherubs, Living Creatures, and Seraphim, embedded in the chronology patterns, which is something that you will not find anywhere else. We think that this lends a great deal of support and credibility to our discussion of God's plan and the chronology associated with it.

Before considering the chronology part more fully, we are going to discuss God's plan as we see it, so that as we discuss the chronology patterns more fully, you will be able to see what part of his plan, God is accomplishing with each pattern.

God's Plan, two Salvations the Church and the World

We have see very compelling evidence, in the previous pages, that God's plan not only includes a church class, but the intent of his plan is to eventually restore "all" who are willing, back to the human life rights that Adam had lost in the garden. Contrary to traditionally taught doctrines, in which many churches limit salvation to only those who have accepted what their individual churches teach, we see that God is not as limited as they are, and that he desires to save all, even those who don't believe the good news now! We don't claim that God will save all, no matter what they do, but we do see that God has designed his plan so that as few as possible will lose out. (*1 Tim 2:3-40*) *This is good, and it is acceptable in the sight of God our Savior, who desires all men to be saved and to come to the knowledge of the truth.*

Many at this time do not believe in God, and for that reason they don't accept the message of salvation. At this time those who say that there is no God are fools, but in the next age it will not be possible for even a fool to err. In the next age the Lord's truth will cover the earth completely. (*Ps 14:1*) *The fool says in his heart, "There is no God." They are corrupt, their deeds are vile; there is no one who does good.*

Isa. 11:9 They will neither harm nor destroy on all my holy mountain, for the earth will be full of the knowledge of the LORD as the waters cover the sea. (NIV)

A Spiritual Church Class First

We understand from the scriptures, that there is a special calling out of a spiritual church class, during the gospel age, (a first resurrection). In that calling out, there are two spiritual classes, the 144,000 and the great company, (Rev chapter 7). The 144,000 is a class that has over come and proved faithful in all things, while the great company is a spiritual class that did not do as well, failing on some point or points, but they are still saved by the grace of God.

A Worldly Class Saved Second

Any others, who do not believe now, will be included in a second resurrection, which will be limited to an earthly inheritance in the millennial age. (*Rev 20:4-6*) *4 I saw thrones on which were seated those who had been given authority to judge. And I saw the souls of those who had been beheaded because of their testimony for Jesus and because of the word of God. They had not worshiped the beast or his image and had not received his mark on their foreheads or their hands. They came to life and reigned with Christ a thousand years.*

5 (The rest of the dead did not come to life until the thousand

years were ended.) This is the first resurrection.

6 Blessed and holy are those who have part in the first resurrection. The second death has no power over them, but they will be priests of God and of Christ and will reign with him for a thousand years.

The second resurrection, will include all those that lived before the time of Christ, and it will also include all those who have since the Gospel age began, either did not hear or did not believe the gospel message of good news. The only exception to this rule, would be someone in this age, who would have had a great deal of knowledge regarding Gods plan, and who had turned against it anyway.

Heb 10:26 If anyone sins deliberately by rejecting the Savior after knowing the truth of forgiveness, this sin is not covered by Christ's death; there is no way to get rid of it. (TLB)

1 Jn 5:16 If anyone sees his brother commit a sin that does not lead to death, he should pray and God will give him life. I refer to those whose sin does not lead to death. There is a sin that leads to death. I am not saying that he should pray about that.

The scriptures call this a second death class. We pray that there are not many, who were, or still will be so foolish!

The Nation of Israel

In the millennial age, when the worldly people are resurrected, there will be no doubt that God does have a plan and they will not need anyone to teach them since God will write it in their hearts. In the following scriptures, we see that this will happen first with the restored nation of Israel. Eventually this salvation, will include all the rest of mankind, who became inheritors of the promises, because of Israel's unbelief at the time of Christ.

(Romans 11:11-12) 11 Does this mean that God has rejected his Jewish people forever? Of course not! His purpose was to make his salvation available to the Gentiles, and then the Jews would be jealous and begin to want God's salvation for themselves. 12 Now if the whole world became rich as a result of God's offer of salvation, when the Jews stumbled over it and turned it down, think how much greater a blessing the world will share in later on when the Jews, too, come to Christ. (TLB)

(Jer 31:33-34) 33 But this shall be the covenant that I will make with the house of Israel; After those days, saith the LORD, I will put my law in their inward parts, and write it in their hearts; and will be their God, and they shall be my people. 34 And they shall teach no more every man his neighbour, and every man his brother, saying, Know the LORD: for they shall all know me, from the least of them unto the greatest of them, saith the LORD: for I will forgive their iniquity, and I will remember their sin no more. (KJV)

Reason for the Church is to Help Restore the Rest of the World

God's purpose for the calling of a heavenly church class, out of the world, is not understood by most of the churches today. It's not, as many seem to think, that God wants us to sit around on clouds, playing on harps. The scriptures indicate that the real reason for the church, is so that it can be used to help restore the rest of mankind back to life rights and fellowship with the Father in the millennium.

Rev 21:2-6) 2 And I saw the holy city, new Jerusalem, coming down out of heaven from God, made ready as a bride adorned for her

husband. 3 And I heard a loud voice from the throne, saying, "Behold, the tabernacle of God is among men, and He will dwell among them, and they shall be His people, and God Himself will be among them, 4 and He will wipe away every tear from their eyes; and there will no longer be {any} death; there will no longer be {any} mourning, or crying, or pain; the first things have passed away." 5 And He who sits on the throne said, "Behold, I am making all things new." And He said, "Write, for these words are faithful and true." 6 Then He said to me, "It is done. I am the Alpha and the Omega, the beginning and the end. I will give to the one who thirsts from the spring of the water of life without cost.

The church, in symbol, is referred to as the bride of Christ, and in the next age, together with Christ, they will be the new Jerusalem, or in other words the government of God. That means that together, both Christ and the church, will rule over the world, as kings and priests, with the intent to restore mankind back to the ability to live without death. That ability or life rights, were lost in the garden when they sinned.

Luke 19:10 Matt 18:11/For the Son of Man came to seek and to save what was lost." (NIV)

Heb 7:25 Wherefore he is able also to save them to the uttermost that come unto God by him, seeing he ever liveth to make intercession for them.

(Rev 21:9-10) 9 And there came unto me one of the seven angels which had the seven vials full of the seven last plagues, and talked with me, saying, Come hither, I will shew thee the bride, the Lamb's wife.

10 And he carried me away in the spirit to a great and high mountain, and shewed me that great city, the holy Jerusalem, descending out of heaven from God,

(Rev 22:1-3) 1 And he shewed me a pure river of water of life, clear as crystal, proceeding out of the throne of God and of the Lamb.

2 In the midst of the street of it, and on either side of the river, was there the tree of life, which bare twelve manner of fruits, and yielded her fruit every month: and the leaves of the tree were for the healing of the nations.

3 And there shall be no more curse: but the throne of God and of the Lamb shall be in it; and his servants shall serve him:

The Millennial Age

The selection of a spiritual church class does not continue for ever. Almost all churches would agree that the gospel age will end at some point. What happens then, is where there is major disagreement. Many think that event is the end of the world, while only a few see that the scriptures talk about another age.

Rev 21:1-4) 1 Then I saw a new heaven and a new earth, for the first heaven and the first earth had passed away, and there was no longer any sea. 2 I saw the Holy City, the new Jerusalem, coming down out of heaven from God, prepared as a bride beautifully dressed for her husband. 3 And I heard a loud voice from the throne saying, "Now the dwelling of God is with men, and he will live with them. They will be his people, and God himself will be with them and be their God. 4 He will wipe every tear from their eyes. There will be no more death or mourning or crying or pain, for the old order of things has passed away." (NIV)

After the church is completed, the rest of the world, is not resur-

rected to a spiritual resurrection, but they are brought back to life with earthly bodies. They will not have full restored life rights until the end of the 1000 years, and that is why it says they “**lived not**” until the 1000 years were over. Once they pass the test of the little season, Rev 20:7-10, then they will have life everlasting. The little season is a term that defines a period of testing that will be similar to Adams test, but this time, those being tested, will have the advantage of having experience with sin and death. They will not be likely to make the same kind of mistake as Adam did originally, since they will have had experience with the penalty, *death, mourning, crying, and pain*.

This answers the question that many people have had, regarding the fall of Adam. They have wondered why God would so severely punish Adam and his race, for such a trivial mistake. As we will see, God knew this would happen and designed his plan accordingly, so that everyone would get the experience needed, so that they could pass the final test at the end of the millennium. **He also knew that small mistakes in children, unless corrected, lead to big transgressions later on**, and so he is letting his children become fully educated, so that they don't fall into error again after they have been restored. See volume 1, “Studies in the Scriptures”, for a full explanation of the permission of evil.

All those who will gain life by this method, will appreciate what they have, much more than if they were just given it. This is similar to those who are born rich, in that they don't appreciate what they have, as much as someone who has had to earn it. For those who take their lessons to heart, the test of the little season at the end of the millennium, will be no problem!

(Rev 20:7-9) 7 And when the thousand years are expired, Satan shall be loosed out of his prison,

8 And shall go out to deceive the nations which are in the four quarters of the earth, Gog and Magog, to gather them together to battle: the number of whom is as the sand of the sea.

9 And they went up on the breadth of the earth, and compassed the camp of the saints about, and the beloved city: and fire came down from God out of heaven, and devoured them.

(1 Cor 15:22-24) 22 For as in Adam all die, even so in Christ all shall be made alive. 23 But each one in his own order: Christ the firstfruits, afterward those who are Christ's at His coming.

24 Then cometh the end, when he shall have delivered up the kingdom to God, even the Father; when he shall have put down all rule and all authority and power.

The Bible Chronology Patterns, Confirm the Divine Plan

As you have seen earlier in this booklet, the chronology patterns confirm that the Bible Student system of chronology, from “the Studies in the Scriptures”, is correct as it was presented well over a hundred years ago. We see that God has designed his plan of salvation around a 7000 year period, and that from the time that Adam fell in the garden, until all who are willing, are restored to perfection, there will be a total of 7000 years.

Several major biblical themes, related to the end, or harvest of the gospel age, for example judgement, who has the right to rule, and the restitution of all things lost in the garden, are confirmed, since the chronology patterns confirm those themes!

Without chronology, we don't have a firm foundation as to where we are in the stream of time, in relationship to Gods plan. There is also a question at the present time, concerning those that think that since we are coming up on the turn of the millennium, the world is going to end. While we would agree that we are close to the end the gospel age, we don't think that the year 2000, has any special significance in the scriptures, by itself. The claim is made by some that the year 2000 is the end of 6000 years of bible history, but as we have seen in this booklet, 6000 years already expired in 1874 AD. For that reason we don't think that method has any validity.

Another claim, which is approximately correct, is that this date is 2000 years from Christ's birth. The only reason we think this is even close, is that we don't agree with the common claim for Christ's birth, (4-5 BC). Even if the 4-5 BC date were correct, that time has already ran out, since 2000 years was up in about 1995-96 AD.

Using the correct birth date, 1.25 BC, as we present it in this booklet, and as its also presented in the studies in the scriptures, the 2000 runs out in 1998.75 AD, which is Oct 1999. That date is, exactly 125 years from 1873.75, which is a very significant date to Bible Students!

What should we think of this? We, ourselves, hold the opinion, that the scriptures indicate that no man may know the day or the hour? If we are looking for anything on that date, we think that it would only be the beginning of a final phase, which would lead to the completion of the church and the Kingdom coming fully in. How long that final phase would take we are not sure, but again only God knows. We are going to live as if the last day of the church were here and then we will not have any problem when it does come!

End of Age is Not the End of the World

An end of the age, is not the same as the end of the world, anyway. The scriptures actually say that the earth will be here forever, so we know that it won't be destroyed.

Eccl 1:4 One generation passeth away, and another generation cometh: but the earth abideth for ever.

Because of misconceptions that translators may have had regarding certain passages, they sometime color the meaning of a translation. If there is a question about the meaning of a word or bible passage, we can look in Strong's and other similar works, to see if it was translated with the correct thought. Strong's concordance, is a well know dictionary, of both the Greek and Hebrew words, as found in the bible.

If you look up, in Strong's concordance, the meaning of the word “world” as found in Matt 24:3, in the King James translation, you will see that it means age, as most modern translations actually give it, not end, as in end of the world. What the disciples had actually asked about in Matt 24:3, was not when the world would end, but when the age would end. This would then tell them when the next age or the millennium would begin.

They were interested in when that would occur, since they knew that when that happened, the kingdom would be returned to Israel, *Acts 1:6-7) 6 So when they had come together, they were asking Him, saying, "Lord, is it at this time You are restoring the kingdom*

to Israel?"

7 He said to them, "It is not for you to know times or epochs which the Father has fixed by His own authority; (NAU)

Israel will be Gods blesser nation in the millennial age. The blessings will come from God, through Christ and the church, (The new Jerusalem), through Israel, and from there to the rest of the world. (Isa. 2:2-3) 2 *It shall come to pass in the latter days that the mountain of the house of the LORD shall be established as the highest of the mountains, and shall be raised above the hills; and all the nations shall flow to it,*

3 *and many peoples shall come, and say: "Come, let us go up to the mountain of the LORD, to the house of the God of Jacob; that he may teach us his ways and that we may walk in his paths." For out of Zion shall go forth the law, and the word of the LORD from Jerusalem.*

A Discussion of Chronology and Prophecy and How they Relate

We believe that all prophetic matters should be examined with a correct understanding of bible chronology in mind, so that we may in the end be found dividing the word of God correctly. 2 Tim 2:15 *Be diligent to present yourself approved to God, a worker who does not need to be ashamed, rightly dividing the word of truth. Since the Apostles time, we have passed through almost 2000 years of history, and yet it seems to be human nature, to wish to leave the fulfillment of the largest portion of prophecy, to just a few years at the end.*

Many prophetic students, want to squeeze almost all end time prophecy, into a future 3.5 or 7 literal years. **God has not been on vacation or asleep during the Gospel age, and we think that a lot of what is being looked for future, will be found to have already happened prophetically, without most even knowing it.** Dan 12:9-10) 9 *He said, "Go {your way} Daniel, for {these} words are concealed and sealed up until the end time.*

10 *"Many will be purged, purified and refined, but the wicked will act wickedly; and none of the wicked will understand, but those who have insight will understand. (NAU)*

Literal Versus Prophetic

Part of the reason for this misconception, is that most read the prophetic word, much too literal. As an example of what we mean by too literal, we see that many scriptures seem to say that the earth is going to burn up in the end of the age. In 1 Cor chapter 3, we see that this is not an actual fire, but the fire will symbolically destroy anything, that is bad or in opposition to Gods kingdom.

(1 Cor 2:14-15) 14 *But the man who isn't a Christian can't understand and can't accept these thoughts from God, which the Holy Spirit teaches us. They sound foolish to him because only those who have the Holy Spirit within them can understand what the Holy Spirit means. Others just can't take it in.*

15 *But the spiritual man has insight into everything, and that bothers and baffles the man of the world, who can't understand him at all.(TLB)*

(1 Cor 3:13-15) 13 *There is going to come a time of testing at Christ's Judgment Day to see what kind of material each builder has used. Everyone's work will be put through the fire so that all can see whether or not it keeps its value, and what was really*

accomplished.

14 *Then every workman who has built on the foundation with the right materials, and whose work still stands, will get his pay.*

15 *But if the house he has built burns up, he will have a great loss. He himself will be saved, but like a man escaping through a wall of flames. (TLB)*

In other words, if we don't build properly upon the true foundation of God's word and Christ, what we have done will not receive a reward. We will still be saved, but we will lose our reward and be in the great company class.

Matt 22:13-14) 13 *"Then the king said to the servants, "Bind him hand and foot, and throw him into the outer darkness; in that place there will be weeping and gnashing of teeth.'*

14 *"For many are called, but few {are} chosen."*

The Message in the Bible is Prophetic

The message that we get from the bible, is sometimes prophetic, or given in many cases in symbol and not in plain language. To be given in symbol means to give the message in a code that can only be deciphered by figuring out what each symbol means.

Sometimes, the bible tells us what the symbol represents, such as in Rev 17:12, where it tells us that the 10 horns are kings. Other times we have to figure it out from the context.

Another easy to understand example, regarding literal versus prophetic, is that we see many weird beasts described in both the book of Rev and Dan. We know that these are symbolic of something, and not actual literal beasts that are going to walk down the street. In Daniel 7:17, we are plainly told that beasts represents kings or kingdoms.

Why is the Bible so Hard to Understand

Some complain about the fact that the bible is written so that its hard to understand, but God has a reason for it. Read Dan 12:9-10 that we just quoted in the previous column. **This hiding in symbol, is done so that those who are Gods enemies, will not know what's happening and they will not be able to interfere with his plans.** Only the true church or the wise, will put enough effort into understanding his plan, to be able to see beyond the symbolism. They of course will be working to help the plan succeed.

With the chronology patterns we see in this book, its easy to see that God has actually been fulfilling prophecy, and controlling events in the world, throughout the entire age, and for that matter all the way back to the time of Adam. The world has in recent years, come to the misconception that God is dead, or that he is asleep, but we know that he has been working out things unseen to the natural eye. **We hope that the study of the patterns in this book, will convince the reader that God is alive and well, and that his enemies had better beware!**

A Discussion Regarding Chronology Expectations Past and Future

Some have lost faith in bible chronology, because of unreasonable expectations as to what it should teach us. Many in the past have predicted the end of the church, or the end of the world, but to no avail. We will show in this booklet, that there is at least one instance, where the date that was picked (1914 AD), was correct, but perhaps in a slightly different sense than originally thought.

As we will see, almost everything predicted about the date, has proven to be true!

Some Actual False Prophets

A word of caution is necessary at this time, in that there are a few other groups out there, who also point to the year 1914. The Bible Students as they exist today, are faithful to the original ideas in regard to that date, but we wish to warn you that there are others who are not. Most of the other groups are putting forth ideas that are out of harmony with the bible. For example, some are advocating that the kingdom did actually come in 1914, and that the church was complete at that time, or that there have been no new spiritual church members selected since then. Some like the Witnesses, even claim that since the kingdom is here, everyone that they preach to, has to accept their message or go into the second death. We do not agree with any of that!

Any time someone tries to claim that you will die or be tormented for ever, if you don't accept what they claim, don't believe them. We know that this falsehood is from the adversary, trying to use fear to gather people to his false doctrines and system. God does not use such tactics, and we know that if there were a final trial for life going on, as there will be in the kingdom, it will be made plain to everyone, and not kept as some obscure and hard to understand secret.

The adversary likes to mix truth with error, and thereby try to defeat the completing of the church, so that the millennial age blessings can't start. The scriptures tell us that he will be cast into prison at that time, and will not be able to deceive anyone until after the end of the 1000 years.

(Rev 20:1-3) 1 Then I saw an angel coming down from heaven, holding the key of the abyss and a great chain in his hand.

2 And he laid hold of the dragon, the serpent of old, who is the devil and Satan, and bound him for a thousand years; 3 and he threw him into the abyss, and shut {it} and sealed {it} over him, so that he would not deceive the nations any longer, until the thousand years were completed; after these things he must be released for a short time.

(Rev 20:7-8) 7 When the thousand years are completed, Satan will be released from his prison, 8 and will come out to deceive the nations which are in the four corners of the earth, Gog and Magog, to gather them together for the war; the number of them is like the sand of the seashore.

He knows that his time is short, and for that reason he has tried to shift attention away from the events that actually did happen, and to completely corrupt the truth of what that date means.

We Intend to Show that the Original Expectations Were Correct

Since the above groups, especially the Jehovah's Witnesses,

have misapplied what the date 1914 represents, this has cast a certain stigma on it, and the events associated with it. That is one of the things that we wish to correct with this booklet. While there were some slight problems with the predictions regarding that date, as we will see, most of what had been predicted, has come to pass.

The Witnesses, for example, do not want to recognize the restoration of Israel, as being from God, but are trying to claim that they themselves are the new Israel. **That Israel would come back as a nation after 1914 AD, was predicted ahead of time by the Bible Students.** Contrary to that, the Witnesses made the claim, in 1932, that Israel would not be the blessing nation and that they were taking Israel's place in the kingdom. This all happened 16 years before Israel was actually and literally restored as a nation in 1948!

The scriptures say that if someone prophesies about something, and it doesn't come to pass, do not listen to them. If it does come to pass, then you should pay attention to the prophet that predicted that it would. **When someone predicts that something is not going to happen and then it does, they are in double trouble!**

We Have Seen in this Booklet, That There Was More to the Bible Student Chronology Than Was Originally Thought

Unfortunately they have caused a stigma to be cast on the 1914 date, that it does not deserve. God has left a surprise for them that will show that they are false prophets, since they have no idea that it exists. They had cast aside all of the other chronology, besides the 1914 date, but the original Bible Students still see that all the rest of it is correct. The patterns that we have seen in this booklet confirm, not only the 2520, but we still see that the 1260, 1845, and the 2500 year Jubilee is correct.

We have seen that not only is the original 1260, 2520 year cycle, that predicted 1914 AD correct, but we see that it's part of a much more comprehensive pattern and purpose. The same thing as we have seen is true of the 1845 and the 2500 which is also a part of a larger pattern. God has saved this much more comprehensive truth for last, knowing that the adversary would try to discredit or corrupt the original, as he has always done in the past. We pray that we can use this booklet to help deliver a mighty and final blow to him, that will help to release the world from his chains of deception!

A Chronology Explanation and Outline

We are going to give a summary of the Bible Student chronology, and the theory that it's based on, so that the reader has at least a partial understanding of it. This will not be a detailed explanation, but hopefully will explain where most of the chronology came from, and what it means. We also hope to show at least some of the reasons why, there was

great expectation for 1914.

Seven 1000 year days

First of all, we see that there are some scriptures that talk about a day with the Lord as being a 1000 years.

Ps 90:4 For a thousand years in your sight are like yesterday when it passes by, or {as} a watch in the night.

2 Pet 3:8 But do not let this one {fact} escape your notice, beloved, that with the Lord one day is like a thousand years, and a thousand years like one day.

If you look at the inside cover of the book, you will see that along the top, there are seven 1000 year periods marked out. This comes from the thought that there would be a week of 1000 year days, from the fall in the garden, until the restoration of mankind at the end of the millennium. If you think about it, it only makes sense that God would have a set time planned out, in which to carry out his plan of salvation. We do not think that he is dealing with the situation haphazardly. We believe that he foreknew the fall and had planned accordingly.

Heb 4:3 For we who have believed enter that rest, just as He has said, "AS I SWORE IN MY WRATH, THEY SHALL NOT ENTER MY REST," although His works were finished from the foundation of the world. (NAU)

An 1845 Year Parallel

One of the other pieces of chronology that we seen in this booklet, is the 1845 year parallel. This concept comes from the thought, that when the Patriarchal age ended at the death of Jacob, God then began to deal with Israel as a nation. From Jacobs death, until the death of Christ, was 1845 years, (1812.75 BC - 32.25 AD). After that point in time, we see that Israel as a nation was not dealt with directly by God anymore, because they had rejected their Messiah, (Christ).

The gospel age church, was formed at that time, from the remnant of the Jews that had accepted Christ. Since literal Israel was not being dealt with after that time, it's then possible to conclude that the church had taken their place as a spiritual Israel. We see this in Rev chapter 7, where they are pictured as a spiritual Israel, made up of 12 tribes, of 12000 each. See also, Romans chapter 11. Seeing that this is true, the next logical question becomes, if literal Israel had 1845 years, and then judgment, how about spiritual Israel or the church? If we go another 1845 years into the future, we come to 1877.25 AD.

A Parallel With the Jewish Harvest

While that date could be correct by itself, we would have no way of telling for sure, unless something happened on or around that date. That date became more promising, after we added up the historical years in the bible, and found that 6000 years of history, from the fall of Adam, ended in 1873.75. See the Second Volume., "Studies in the

Scriptures", for a discussion of how the dates were added up. **The 1873.75 date was exactly 3.5 years before the 1877.25 date!**

See page 15 for a chart of the dates in this discussion, and an outline of what we think is parallel, between the two ages. We intend to complete a timeline, to be placed at the end of this booklet, showing how 7000 years of dates add up, in great detail. It will be included as a separate document because of time restraints.

The 3.5 Years Sounds Very Familiar

Those who are familiar with bible prophecy, should recognize that 3.5 years, is the exact length of our Lords ministry. This is confirmed by those who have studied the gospels, as well as the 70 week prophecy which comes from the book of Daniel. We will consider that prophecy, a little more fully, further onward in this explanation. At a day for a year which we will discuss further on, the last week of that prophecy would be 7 years. The Messiah was to have been cut off in the midst of that last week, and that was exactly where it happened, (3.5 + 3.5 = 7)..

From 28.75 AD where our Lords ministry began, until he was crucified, was exactly 3.5 years! We now have a 3.5 year span of time marked off just before the end of both 1845 year spans. The second leg of our 1845 year prophecy, is now looking more interesting, but we still need a couple of other pieces of the puzzle, before we can conclude that we are on the right track.

In the time of Christ, we see that Jerusalem was destroyed in 69-70 AD. The fall of 69 would be 68.75, and that was when Titus came up against the city, and then withdrew until the spring. The Christians having been warned in Luke to flee the city when they saw armies surround it, did so, and thus were saved from the destruction and death that came upon the city, when Titus returned in the spring of 70 AD.

Luke 21:20-22) 20 "But when you see Jerusalem surrounded by armies, then recognize that her desolation is near. 21 "Then those who are in Judea must flee to the mountains, and those who are in the midst of the city must leave, and those who are in the country must not enter the city; 22 because these are days of vengeance, so that all things which are written will be fulfilled.

A 40 year Harvest

That date, 69 AD, was exactly 40 years from the time that Jesus had began his ministry at the river Jordan, (68.75-28.75 = 40). Forty in the bible seems to represent a time of testing, such as when Jesus was tempted in the wilderness, for 40 days and 40 nights. The Jews had failed their testing, and at the end of the 40 years, their temple and nation was destroyed and they were scattered amongst the nations. They were not able to own land again until the year 1917AD!

Destruction of Jerusalem Is a Parallel

That we had a 40 year period of testing on the first end of the 1845 years, would lead us to ask, what about the other end of the 1845? If we add 40 to 1873.75, we would then get 1913.75 (Oct 1914). This, as an exact parallel to the destruction of Jerusalem, in 70 AD, which was as we will see later, the beginning of the days of vengeance. This vengeance, came upon the European kingdoms, who had been illegally associated with the false church state system.

Seven Times of Punishment

Another reason that 1914 AD was considered at that time, was that God had also warned Israel that they would have 7 times of punishment pass over them, if they were unfaithful to their covenant, (**Lev 26:18-28**).

Beside the original warning given in Leviticus, the Bible Students had also considered the 7 times of Daniel 4:32, as a picture of this. While its true that the prophecy in Daniel, originally only referred to Nebuchadnezzar, we see that it also is a picture or an antitype of greater things. There may actually be a couple of different applications. The first, would be the seven times that will pass over the world, from the fall of Adam, until the restoration at the end of 7000 years.

In the second application, using this same principle, in the case of Israel, but seeing that it was seven times 360, rather than 1000, we get 2520 years. **Don't forget, we already have our justification for the seven times of punishment foretold for Israel in Lev. Even if we discounted the Daniel scripture, we could still get our application from Lev.**

How Do We Get 360 as a Time?

If there was going to be 7 times of 360 punishment come upon Israel, it seems reasonable to ask, how did we determine how long was a "time"? That question it turned out, could be answered from a couple of different sources. First of all, we see that from the time of the sentence of the 7 times that was pronounced against Nebuchadnezzar, until it was carried out, was exactly 12 months later, (Dan 4:29-33). In the bible, a month is 30 days and a year of 12 months is 360 days, or a biblical "time".

Second, there is another set of prophecies that predict a terrible beast, (government), that comes and makes war with the saints. **The bible gives for the same time period, three different descriptions.** We have 1260 days, 42 months, and 3.5 times. **If we consider that 3.5 times 360 is the same as 1260 days, it follows that a time is 360 days (3.5 x 360 = 1260).** In the bible a month is counted as 30 days, so we see that 42 months, is also the same as 1260 days, or 42 times 30. As to how we get this equal to years, we will consider that next.

A Day For a Year?

Since we now have 2520 days, regarding the seven times of punishment, we could look at this as being literally 7 years. Some of course want to move all of this into the future, as a literal seven years, but as we have seen earlier in the book, it fits prophecy much better, at a day for a year.

At a day for a year, we would get 2520 years of punishment for Israel. If we counted from the time that Israel lost their civil power to Nebuchadnezzar, in 607 BC, and we were to go 2520 years into the future, we arrive at 1914 AD. **While Israel did not immediately become a nation at that time, the Jews were allowed to own land after 1917, which was a result of the 1914 war! Of course just because something works doesn't make it correct, but when we see that same number, in a pattern of 2520's and 1260's, as we have seen in this booklet, it becomes much more likely!**

Since we see that the 2520 years reached to 1913.75, just as the 40 years did, we can see that the original Bible Students had several good reason for looking at that date ahead of time, and for considering it to be very important.

Why a Day For a Year

Since some might object to this manner of calculation, and prefer to move it all future, to a literal 7 years, we will give some other examples where God uses the day for a year method. First of all, we find a couple of day for a year examples in Numbers 14: and Ezekiel 4:. In Numbers God punished the Israelites 40 years at a day per year. In Ezekiel we also see Ezekiel lay on his side at a day for each year of transgression.

(Num 14:34) 34 After the number of the days in which ye searched the land, even forty days, each day for a year, shall ye bear your iniquities, even forty years, and ye shall know my breach of promise.

Ezek 4:4-6) 4 "As for you, lie down on your left side and lay the iniquity of the house of Israel on it; you shall bear their iniquity for the number of days that you lie on it.

5 "For I have assigned you a number of days corresponding to the years of their iniquity, three hundred and ninety days; thus you shall bear the iniquity of the house of Israel.

6 "When you have completed these, you shall lie down a second time, {but} on your right side and bear the iniquity of the house of Judah; I have assigned it to you for forty days, a day for each year.

Seventy Weeks and a Day Per Year

Since some might still try to claim that the above scriptures were a special case, we also need to examine the 70 weeks prophecy found in Daniel. Many students of the bible are familiar with the prophecy of the 70 weeks, in Dan chapter 9. The prophecy indicates, that the 70 weeks should be counted from the command to rebuild the city, which began with the laying of the temple foundation.

Dan 9:25 "So you are to know and discern {that} from the

issuing of a decree to restore and rebuild Jerusalem until Messiah the Prince {there will be} seven weeks and sixty-two weeks; it will be built again, with plaza and moat, even in times of distress. (NAU)

From the Foundation of the Temple Until the Messiah Was Not 70 literal Weeks!

We know that from the time that the foundation of the temple was laid, until the Messiah came, was not 70 literal weeks. If we use the formula of a day for a year, we get much better results, in predicting the arrival of the Messiah. Seventy weeks at a day for a year is 490 years, which from the laying of the foundation of the new temple, until the midst of the last seven yr. week, is 486.5 years later. That is exactly the time where we find our Lord crucified (April 33 AD).

The last week of 7 years, when divided in half, is exactly 3.5 years, which is the actual length of his ministry. This is widely believed and accepted by many different schools of thought, in one form or another, and it again confirms the day for a year principle. Some have an earlier date for the crucifixion, which we don't agree with, but they use the same basic method of calculating at a day per year.

The Last 3.5 Years Was Fulfilled at the First Advent

We do disagree with those who wish to take the 3.5 years that are left of the last week, and move it forward almost 2000 years. The 3.5 years to us, seems to fit very well at the first advent, as a time of exclusive witnessing to the Jewish house. After the 3.5 years we come to Cornelius, where the spread of the gospel to the Gentiles began, Acts chapter 10. There is no scriptural indication that the 2000 years should be skipped over, before the fulfillment of the last 3.5 years!

There is actually an obvious fulfillment of another part of that prophecy anyway. The one who was to come and destroy the city, and the sanctuary, was literally Rome. There is a greater antitypical fulfillment of this, when the flood of Papacy took over Rome and destroyed the true sanctuary, which was the gospel age church. *Dan 9:26 "Then after the sixty-two weeks the Messiah will be cut off and have nothing, and the people of the prince who is to come will destroy the city and the sanctuary. And its end {will come} with a flood; even to the end there will be war; desolations are determined. (NAU)*

Rev 12:15 And the serpent cast out of his mouth water as a flood after the woman, that he might cause her to be carried away of the flood. (KJV)

The Jews Were in Expectation at the Time

The day for a year concept is the reason the Jews at the time

of Christ were in expectation that the Messiah was due to come. *Luke 3:15 And as the people were in expectation, and all men mused in their hearts of John, whether he were the Christ, or not;*

Unfortunately for them, most refused to believe that the Messiah was actually Jesus.

As we shall see, even on this end of the age, we need to be careful in regard to the coming of the Lord. If we have the wrong expectation, and we refuse to consider any other reasonable scriptural possibility, we may be found to be a foolish virgin, (Matt 25:1-13).

These scriptures are ignored by most in the bible, and many at this time, still think that this should be a future literal time period of 3.5 or 7 years, at the end of the age, but we don't agree. The literal day for a day conclusion, is actually a rather recent modern thought. From very early on in the church, until about the time of the reformation, most bible scholars believed in a day for a year method of counting prophetic time, rather than a literal count of the time period. They felt that the day for a year method was correct, because the 70 week prophecy had been successful in predicting the first advent of Christ. In scientific circles, a theory that successfully predicts something, not previously known, is considered very likely to be correct, and the same thing is true of bible theory.

What is not known, is that the idea that this was not a day for a year, came from a couple of Catholic writers, who were trying to divert the judgment finger of God, that was already pointed at the Papal system in their time. The literal, day for a day method, was proposed by the Jesuit Ribera in 1585 AD and again by the Jesuit Alcazar in 1614 AD.

The Dates 539-1799 AD

The reason that they were concerned about it, was that the day for a year chronology was pointing directly to Papacy, because it marked off a period of 1260 years, (539-1799 AD). That was the time that it was predicted, that the false system would be in power, and the only candidate that could possibly fit that description, was the Papal power that existed at that time.

They had begun to influence and control civil power at almost exactly the 539 AD date, predicted by the theory. We seen earlier in the book, that the dates that were picked for the beginning and the end of this time period were correct. Again since it is part of a much bigger chronological pattern, that has other dates already fulfilled, it makes these dates unchangeable also!

History actually fits this period very well. At that time, 539 AD, Justinian the Roman emperor, used the army to conquer an area that was held by a different faith than the Catholics. This was the Arians who did not believe in the trinity doctrine. After the Arians defeat at Ravenna, in 539-40 AD, shortly after that time, their faith no longer existed in the western empire. Some of the land that was conquered during those bat-

ties, was later given to the Papal power. This marked the beginning of military cooperation, between the false religious system and the civil power. After that time, they claimed the right to put down all others of different beliefs with force.

The attitude of being able to force all others to their belief, got worse and worse after that time, until there was eventually no voice of disagreement able to speak in the false church system. They then were without hope of reform, since they would listen to no one, including the word of God. *Rev 2:20-21* 20 "But I have {this} against you, that you tolerate the woman Jezebel, who calls herself a prophetess, and she teaches and leads My bond-servants astray so that they commit {acts of} immorality and eat things sacrificed to idols.

21 "I gave her time to repent, and she does not want to repent of her immorality. (NAU)

The 1799 AD date, predicted by the day for a year theory, had not arrived yet, at the time that the attempt was made to discredit this way of calculating. **Since then, we see historically, that Papacy did lose its civil support in 1799 AD, exactly where it was predicted to happen, by the day for a year theory!** Napoleon had captured the Pope just prior to that date and took him to prison in France, for not paying him a tax. That Napoleon could do that, and not have God strike him dead, showed the rest of the nations that they had nothing to fear from God, in regard to Papacy.

A 1260 year Reign of Terror

The 1260 years that we have referred to in this section, comes from the bible in several different places. As we mentioned before, we see that it doesn't matter if the prophecy uses 1260 days, 42 months, or 3.5 times (360), the results at a day for a year are the same. The prophecy in these areas is referring to the false church and state system, that would rule for 1260 years, from 539 AD - 1799 AD. After that time its power was to be broken. There are "seven References", and seven in the bible represents something that is complete! (1) *Rev 11:2* "Leave out the court which is outside the temple and do not measure it, for it has been given to the nations; and they will tread under foot the holy city for **forty-two months**.

(2) *Rev 13:5* There was given to him a mouth speaking arrogant words and blasphemies, and authority to act for **forty-two months** was given to him.

(3) *Dan 7:25* "He will speak out against the Most High and wear down the saints of the Highest One, and he will intend to make alterations in times and in law; and they will be given into his hand for **a time, times, and half a time**.

(4) *Dan 12:7* I heard the man dressed in linen, who was above the waters of the river, as he raised his right hand and his left toward heaven, and swore by Him who lives forever that it would be for **a time, times, and half {a} {time;}** and as soon as they finish shattering the power of the holy people, all these {events} will be completed.

(5) *Rev 12:14* But the two wings of the great eagle were

given to the woman, so that she could fly into the wilderness to her place, where she was nourished for **a time and times and half a time**, from the presence of the serpent.

(6) *Rev 11:3* "And I will grant {authority} to my two witnesses, and they will prophesy for **twelve hundred and sixty days**, clothed in sackcloth."

(7) *Rev 12:6* Then the woman fled into the wilderness where she had a place prepared by God, so that there she would be nourished for **one thousand two hundred and sixty days**.

The church state system had falsely held power for 1260 years, from 539 AD - 1799 AD. After the break up of church and state in 1799, Papacy has tried to regain the power they had lost, but the Lord has other plans for them. Besides the false church, the Lord intended to punish the kingdoms that had been associated with the Papal system illegally, and bible chronology indicated that this would happen in 1914 AD.

Rev 17:12-14 12 "The ten horns which you saw are ten kings who have not yet received a kingdom, but they receive authority as kings with the beast for one hour.

13 "These have one purpose, and they give their power and authority to the beast.

14 "These will wage war against the Lamb, and the Lamb will overcome them, because He is Lord of lords and King of kings, and those who are with Him {are the} called and chosen and faithful."

This happened as predicted, in that after the 1914 AD war, most of the original kings involved in that system, no longer existed, at least in the same form of government that they originally had.

The early Bible Students felt and some still feel, that there will be a short and final rise back to power, of church and state. If that happens, there would be persecution of the true church again, but that prediction is uncertain at this time, and so we continue to watch, in case it would happen? We ourselves, think that the original system from 539-1799, fulfilled the prophecy regarding the rise to power, but in case we are wrong, we continue to watch!

Papacy Lost its Civil Power Exactly Where it Should Have

The final result, was that by 1799-1800, all of the kings had withdrawn their political support from the church and state system. There were a few that went back to Papacy for a short time after that, but by 1870, they again withdrew their support. **That there was no civil power left to them in 1799, just as predicted, was not a coincidence. This fulfillment, lends a great deal of credibility to the concept of a day for a year.**

See the editors preface to Barnes notes on the book of Revelation, as well as the footnotes involved in that preface for more information and history on the day per year contro-

versy. The history of the concept of a day for a year, and the struggle over it, is explained there, as well as naming the two individuals from the Catholic system, who tried to explain it away.

Isaac Newton Believed in a Day For a Year

Despite their efforts to get rid of the day for a year thorn, even after that time, many still believed in it, including a well known bible scholar named Sir Isaac Newton. We find today, that the scientific community does not want to advertise the fact that he was an avid scholar of the bible. Most history books only tell you about his scientific accomplishments. Today, its considered politically incorrect to believe in the bible, so they do not want to admit that he believed in it . Much of what he wrote, he was afraid to have published, until after his death, because of the fear of persecution at the time. But if you look for his writings on the bible, you will find that they contain the day for a year concept!

The Adventists and Bible Students

The Adventist also used the day for a year method, but unfortunately for them, they didn't have the exact starting place, and they tried to end everything at the same time, which led to a wrong conclusion about the end of the age.

The Bible Students, then picked up the concept of a day for a year, and made some corrections, additions and refinements, to what was known up to that time, and that chronology is what we are going to prove correct in this book.

A Discussion of the Original Bible Student Chronology and its Prophetic Expectations

We are now going to begin our discussion of the Bible Student chronology and how its related to Gods plan. It had been predicted that a great time of trouble would occur in 1914 AD, and as history shows, that definitely did happen with the outbreak of WW1. Trouble in one form or another, has not ceased since then, in that we have had another world war, as well as never ending world trouble and problems!

The only problem with the prediction of trouble, was that it was thought that it would be over within a few years. We now see more clearly that the scriptures tell us, that the trouble would not finish as quickly as was thought. We see that it would come in spasms, gradually getting worse, until the climax or birth of the next age.

(1Thes 5:1-3) 1 But of the times and the seasons, brethren, ye have no need that I write unto you.

2 For yourselves know perfectly that the day of the Lord so cometh as a thief in the night.

3 For when they shall say, Peace and safety; then sudden destruction cometh upon them, as travail upon a woman with

child; and they shall not escape.(KJV)

That there was going to be travail and spasms of trouble, was actually known before hand, but the church has always hoped for the speedy return of the Lord, so that the time of blessing could come. For that reason it looked for and hoped that the trouble would be short lived. God works on a much longer time frame than we do, and he does things much more slowly than we expect.

Daniel Gives a Picture of the Steps

There actually seems to be about 7 steps to this process of trouble, as described by Daniel, which indicates a period of time! The image in Daniel chapter 2 was symbolic of 4 universal empires that were to come into existence, starting in Daniels time, 607 BC. They were (1) Babylon, (2) Medes and Persians, (3) Greece, and (4) Rome.

The toes of iron and clay, represented the mixture of church and state, that had taken over the original power of the Roman empire in 539 AD. This was called by the false church "the Holy Roman Empire", but God called it, "Babylon the Great". *Rev 17:5 and on her forehead a name {was} written, a mystery, "BABYLON THE GREAT, THE MOTHER OF HARLOTS AND OF THE ABOMINATIONS OF THE EARTH."*

The image was eventually smote on its feet, (church and state), in order to break up and destroy this false oppressive power. *(Dan 2:34-35) 34 As you looked, (1) (33AD) a stone was cut out by no human hand, and (2) (1517) it smote the image on its feet of iron and clay, and (3) (1799) broke them in pieces;*

35 (4) then the iron, the clay, the bronze, the silver, and the gold, all together were broken in pieces,(1914>) and (5) became like the chaff of the summer threshing floors; (1914>) and (6) (1989>) the wind carried them away, so that not a trace of them could be found. But (7) (? AD) the stone that struck the image became a great mountain and filled the whole earth. (RSV)

The Stone is Jesus

Some think that none of this can happen, until the church is complete, since they think that Christ head and Body, is the stone. **We prefer to go with the scriptural statements, that the Lord Jesus is the stone that was cut out without hands.** *Eph 2:20 having been built on the foundation of the apostles and prophets, Christ Jesus Himself being the corner {stone} Isa. 28:16 Therefore thus saith the Lord GOD, Behold, I lay in Zion for a foundation a stone, a tried stone, a precious corner stone, a sure foundation: he that believeth shall not make haste.*

Only at the seventh step, after the church is complete, is the kingdom of God fully established over the earth.

Destruction of the Old World Order

If we are looking at the Daniel picture correctly, we see that

the reformation with Luther, was a major blow to the Papal system, (1517). The French revolution and the historical fact of Napoleon carrying the Pope away to prison, finally broke the Papal civil power, causing the kings to desert her, (1799).

The war that occurred in 1914, destroyed or finally shattered the old world order of the kings, that had reigned illegally with the Papacy during the dark ages, of the 1260 years, (539-1799 AD).

The Oct 1989 date was the date that Communism fell and the breakup of Eastern Europe began. This date seems to be the date that all nations, including the U.S., began to enter into a final spasm of trouble that will usher in the mountain or the kingdom.

Why Did They Fall Into Error?

The reason that this false system came about, was because the bishops that ruled over the church, early on in the gospel age, began to compete with one another over who had the exclusive right to rule the church. The bishop of Rome eventually won out over the other bishops, because he lived in the seat of the old Roman empire. This gave him special status and he eventually took forceful control of the entire church. The bishops of Rome, after that time, began to be called Popes, as they are today. This was not right since no one in the church was supposed to be above anyone else, but we were supposed to be servants to one another.

The other thing was that the church was not supposed to be involved in worldly affairs, but it had become tempted into grasping civil power and it then misused the power that it had gotten. It began to persecute or kill those that didn't agree with the oppressive church system and in many cases, this was actually those who were being faithful to the Lord. Eventually, Papacy or the Popes of the dark ages, gained the power to dictate to the kings themselves. That is why we see the woman, riding on the beast, in Rev chapter 17. She was called a harlot, in that she was not faithful to the Lord. That she was riding on the beast, implies that she was controlling it.

The False Church System Was to be Judged at a Set Time

For that reason, the Lord judged this church and state system guilty, and promised that at a set time, it would be punished. As we have seen in this book, there was a special 40 year harvest period that ended in 1914, that began the process of vengeance. In 1914, the Lord began to destroy the kings who had been associated with Papacy.

Rev 2:20-23) 20 "But I have {this} against you, that you tolerate the woman Jezebel, who calls herself a prophetess, and she teaches and leads My bond-servants astray so that they commit {acts of} immorality and eat things sacrificed to idols.

21 "I gave her time to repent, and she does not want to repent of her immorality.

22 "Behold, I will throw her on a bed {of sickness} and those who commit adultery with her into great tribulation, unless they repent of her deeds.

23 "And I will kill her children with pestilence, and all the churches will know that I am He who searches the minds and hearts; and I will give to each one of you according to your deeds.

Rev 6:9-11) 9 When the Lamb broke the fifth seal, I saw underneath the altar the souls of those who had been slain because of the word of God, and because of the testimony which they had maintained;

10 and they cried out with a loud voice, saying, "How long, O Lord, holy and true, will You refrain from judging and avenging our blood on those who dwell on the earth?"

11 And there was given to each of them a white robe; and they were told that they should rest for a little while longer, until {the number of} their fellow servants and their brethren who were to be killed even as they had been, would be completed also.

Rev 17:1-2) 1 Then one of the seven angels who had the seven bowls came and spoke with me, saying, "Come here, I will show you the judgment of the great harlot who sits on many waters,

2 with whom the kings of the earth committed {acts of} immorality, and those who dwell on the earth were made drunk with the wine of her immorality."

Rev 18:21 Then a strong angel took up a stone like a great millstone and threw it into the sea, saying, "So will Babylon, the great city, be thrown down with violence, and will not be found any longer.

Rev 18:9-10) 9 "And the kings of the earth, who committed {acts of} immorality and lived sensuously with her, will weep and lament over her when they see the smoke of her burning,

10 standing at a distance because of the fear of her torment, saying, "Woe, woe, the great city, Babylon, the strong city! For in one hour your judgment has come."

Rev 18:20 "Rejoice over her, O heaven, and you saints and apostles and prophets, because God has pronounced judgment for you against her."

The trouble that came because of this judgement, happened in Oct 1914, just as predicted in the "Studies in the Scriptures".

End of Age Harvest

Since the original 40 years at the first advent was a harvest of the Jewish system, we should expect that the 40 years on this end of the age, would be a gospel age harvest, on spiritual Israel. See page 15 in this booklet for a chart of this. For those who don't think that there is going to be an end of the age harvest, we see that the concept of the end of the age harvest is described in the gospels by Jesus.

Matt 13:30 "Allow both to grow together until the harvest; and in the time of the harvest I will say to the reapers, "First gather up the tares and bind them in bundles to burn them up; but gather the wheat into my barn."'" (NAU)
Matt 13:39 and the enemy who sowed them is the devil, and the harvest is the end of the age; and the reapers are angels. (NAU)

A Jewish Harvest A Gospel Age Harvest

Just as there was to be a harvest at the end of the Gospel age, there was also a Jewish harvest. *Luke 10:2 And He was saying to them, "The harvest is plentiful, but the laborers are few; therefore beseech the Lord of the harvest to send out laborers into His harvest. (NAU)*

We think that the events that occurred at the Jewish harvest, are a picture of things that we could expect on this end of the age. Some of those things would be spiritually discerned and not obvious to the natural eye, but others events that occurred then would be obvious to anyone.

The other event that was considered by the Bible students, as a type or picture prior to 1914, was the destruction of Jerusalem in 70 AD. When that city was destroyed, small forces of Jews had held out for 3 years until 73 AD. Because of that, many of the original Bible Students, had thought that Israel would be restored about 1917, since that date was parallel to the original events in 70-73 AD.

That we saw a destruction of Israel as a nation in 69-70 AD, pictured that there should be a severe time of trouble in 1914, come upon the kings that had been associated with Papacy. As we can now see, that is a historical fact!

Israel's Fall Should Parallel Their Rise

Because of the trouble expected upon the nations at the time it was expected that Israel would return as a nation shortly after that time. In other words as Israel went down, it was considered that they would return in exactly the same manner.

What was not considered closely enough, was that Israel as a nation did not exist before 70 AD either. They were in subjection to the Romans at the time. For that reason, we should not have expected an actual country, that early in the process of restoration.

The 1878 date, beside being events that dealt with the spiritual house, was a key date in the process of restoring the Jews back to their homeland. The Berlin congress of nations (1878), gave the Jews the right to settle in Palestine, a right that they had been denied before that time. Since this was 1845 years from where they began to lose their religious standing before God in the original parallel, in 33 AD, we should, after that time, expect them to start to return to favor, so that they could be the blessing nation in the next age.

The right to return to the land, raised Jewish hopes after 1878, so that Zionism was established, a few years later. Zionism represents the thought that they should have a national homeland of their own.

On this end of the age, the land was under the domination of Britain, who exactly in 1917, passed a law that allowed Jews to buy land in Palestine. **Since the Jews were then able to buy and hold land in Israel, they were actually back to the original condition, that they had prior to their destruction in 70 -73 AD.**

This is exactly what we should have expected from the parallel of their destruction. The right to own land, was a major step towards the eventual restoration of Israel in 1948. Jews from all over the world were taking up collections and buying the land back from their Arab neighbors.

How Long Would it Take?

As an interesting side note, we see from the parallel that Israel was to start to gradually return as a nation after 1877.75 AD, and then after 1917, much more quickly. The question was how long would it take. Babylon captured Israel in 606.25 BC which was where the 70 year desolation began as well as the 2520 years of Gentile power. It took 70 years for Israel to return from Babylon, counting from the first carrying away by Nebuchadnezzar.

According to the modified chronology, we discussed in an earlier section, this was not the time of the destruction of the temple, but was the time that he captured Israel, and made them a vassal state. There were at least two other carrying away, after that first time. After Cyrus issued the decree, they began to return in 536.25 BC, exactly 70 years later. **If we add this same 70 on to the 1877.75 date, we get 1947.75 AD, (Oct 1948), which is where Israel became a nation!**

A 2500 year Cycle The Prophetic Jubilee

Another important type in the law, that was considered by the original Bible Students, was the Jubilee cycle. In the scriptures, it was an important part of the law, in which the Israelites were to be released from debt and slavery. It's based upon a 7 year cycle, which was repeated 7 times. This gave 49 years, of seven times seven. The very next year, or the fiftieth, was called the Jubilee year, and that was the year in which all debt was to be forgiven, and all slaves were to be released from servitude.

Some think that the cycle was every 49 years rather than every 50, but we believe that it was every 50. They think that the 50 th years is not only the end of a cycle and a jubilee year, but they count it as the first year of the next 50 year cycle. We don't see where the scriptures indicate that, and the

chronology that we considered regarding the 2500 year pattern of years, does not agree with that either.

(Lev 25:8-14) 8 And thou shalt number seven sabbaths of years unto thee, seven times seven years; and the space of the seven sabbaths of years shall be unto thee forty and nine years. 9 Then shalt thou cause the trumpet of the jubile to sound on the tenth day of the seventh month, in the day of atonement shall ye make the trumpet sound throughout all your land. 10 And ye shall hallow the fiftieth year, and proclaim liberty throughout all the land unto all the inhabitants thereof: it shall be a jubile unto you; and ye shall return every man unto his possession, and ye shall return every man unto his family. 11 A jubile shall that fiftieth year be unto you: ye shall not sow, neither reap that which groweth of itself in it, nor gather the grapes in it of thy vine undressed. 12 For it is the jubile; it shall be holy unto you: ye shall eat the increase thereof out of the field. 13 In the year of this jubile ye shall return every man unto his possession. 14 And if thou sell ought unto thy neighbour, or buyest ought of thy neighbor's hand, ye shall not oppress one another: (KJV)

Acts 3:19-21) 19 "Therefore repent and return, so that your sins may be wiped away, in order that times of refreshing may come from the presence of the Lord; 20 and that He may send Jesus, the Christ appointed for you, 21 whom heaven must receive until [the] period of restoration of all things about which God spoke by the mouth of His holy prophets from ancient time.

In volume 2, "Studies in the Scriptures", we find that there is an anti-typical lesson to this Jubilee, in that $50 \times 50 = 2500$ years. From the time that Israel was able to keep the last possible Jubilee in 626.25 BC, before they were carried to Babylon, we count 2500 years to 1873.75 AD. **In other words the anti-typical Jubilee also pointed to 1873.75, which was the end of 6000 years since the fall in the garden.** Its was also the beginning of the 1000 year period which will end with all mankind being restored back to the original perfection and life that Adam had, (2873.75 AD).

Regarding the 6000 Years See the Second Volume and the Timeline Supplement

In regard to the 6000 years ending in 1873.75 AD, we recommend reading the second volume, where it explains how the years of the bible are added up. See also the timeline, which is a supplement to this booklet, that shows how the time is added up. It contains both the traditional and the 19 year modified timeline, so that you can compare between the two.

There are other methods advocated by other groups, but we feel this one is correct, in that there are 6000 years, up to 1874 AD. The chronology patterns in this booklet add a great deal of evidence to the thought that the Bible Student method is

correct, with perhaps the one small modification needed, regarding the carrying away to Babylon, that we mentioned in an earlier section.

The Bible Students see that the Lord has designed his plan of recovery for the race, around a 7000 year time period. That is why we think that the end of the 6000 years, in 1873.75 AD, is an important date. We are now in the start of the 7th 1000th year day and for that reason, we would expect more important things to begin to happen than what had happened previous to that time.

Why Didn't the Kingdom Start There?

There actually is a question yet in regard to the 1000 year day, at this time, in that it was at one time thought that as soon as the seventh, 1000 years would start, the kingdom of blessing would be here. There are two different ways that question could be answered. One explanation, is that the day of blessing is going to be only a 1000 years long, starting in 1873.75 AD. **The blessing started with the church, and the time of restitution or blessing for the world, still awaits the completion of the church. The restoration would still finish exactly at the end of the 7th 1000 years.**

The second explanation is that there is an overlap of the two ages and that whatever time the ages overlap on this end, we will have the same overlap on the other end, past the end of the 7000 years. The reason for the overlap would be so that the testing of the little season, could be carried out after the end of the 7000th year?

Regardless of which is true, we see that some obvious events began to occur, that are leading to the establishment of the kingdom after 1873.75 AD. One of those events was the 40 year harvest at the end of the age, that we have already mentioned. Another is that the returned Lord, began to restore Israel back to their land, in preparation for the millennial kingdom.

There are also some bible prophecies, that indicated that the large kingdoms that existed at that time, would begin to be weakened and broken into smaller nations. Historically all of that has happened, just as was thought. The only event that is difficult to prove, is the harvest at the end of the age since that's spiritually discerned, but all the rest of the events, that we have already mentioned, can be seen as actual events.

Israel is back in its land, and the nations are not ruled over by kings and large colonial powers anymore. Even the Soviet block has been broken up into smaller pieces, and as we have seen, the time that it happened (1989 AD) was predicted by the 2520-1260 chronology pattern ahead of time!

Yes we did have the patterns before 1989, but we weren't sure what was going to happen then, because we didn't have as good an understanding of the patterns as we do now.

One misconception that some have regarding the beginning of the 7th 1000 year period, is in regard to when the millennial blessings will come and the resurrection of the dead will begin. **We don't think that the restitution to life for the world, starts at the beginning of that 1000 year period, but only that it would be complete by the end of that time period.** We have seen this earlier, in the chronology patterns that we considered. The gospel age church class, needs to be completed first, before that kind of blessing can happen, and we are waiting for that to be accomplished.

Fore-gleams

This does not mean that nothing has happened yet, as some think. The world is receiving fore-gleaming of blessings already, in that we only have to look at what has been invented since 1874. There were no cars, lights, planes, phones, tv or anything that we take for granted, before that time. Besides earthly inventions, other things that are leading to the coming kingdom, have occurred.

Besides the time of trouble, we see the beginning of the resurrection of the church and the restoration of the nation of Israel, back to their land. Even though Israel was not a part of the original garden of Eden, they are part of the means by which mankind will be restored back to their original condition. We will explain about the resurrection of the church later on in this booklet.

(Ezek 36:24-27) 24 For I will take you from among the heathen, and gather you out of all countries, and will bring you into your own land.

25 Then will I sprinkle clean water upon you, and ye shall be clean: from all your filthiness, and from all your idols, will I cleanse you.

26 A new heart also will I give you, and a new spirit will I put within you: and I will take away the stony heart out of your flesh, and I will give you an heart of flesh.

27 And I will put my spirit within you, and cause you to walk in my statutes, and ye shall keep my judgments, and do them. Ezek 36:35) 35 And they shall say, This land that was desolate is become like the garden of Eden; and the waste and desolate and ruined cities are become fenced, and are inhabited.

(Rom 11:11-12) 11 Does this mean that God has rejected his Jewish people forever? Of course not! His purpose was to make his salvation available to the Gentiles, and then the Jews would be jealous and begin to want God's salvation for themselves.

12 Now if the whole world became rich as a result of God's offer of salvation, when the Jews stumbled over it and turned it down, think how much greater a blessing the world will share in later on when the Jews, too, come to Christ. (TLB)

The Jubilee anti-type, points to a full release from sin and death, as well as the cancellation of all debt owed to justice, from the fall in the garden, by the end of 7000 years, not the

beginning!

Return of Israel

As we mentioned before, it was originally thought that both the completion of the church and the restoration of Israel would occur very shortly after 1914. Some have criticized this prediction, because Israel did not come back as soon as thought, since it was 34 years later, rather than the 3-4 years later, advocated at the time.

All we can say is, we will let the prediction speak for itself, in that very few at the time, even thought of predicting that they would return after a 2000 year absence, let alone putting a date on it. As we have seen earlier, the process of restoring Israel, started when predicted in 1917, but it just took longer to complete, than was originally thought at the time.

(Deut 18:21-22) 21 If you wonder, 'How shall we know whether the prophecy is from the Lord or not?' 22 this is the way to know: If the thing he prophesies doesn't happen, it is not the Lord who has given him the message; he has made it up himself. You have nothing to fear from him. (TLB)

As the kings that had been associated with the false church system, 539-1799 AD, began their final destruction in the time of trouble that came in 1914, we have also seen the rightful heir to the civil power of the kingdom, gradually restored back to their land, and they have become a powerful nation. This began to visibly happen in 1917, with the Jews acquiring the ability to own land in Israel, (Belfour declaration). Eventually there were enough Jews in the holy land, that the nation was formed again, in 1948 AD, almost 1900 years after its original destruction.

The restoration happened as predicted, but it took longer than expected! We still expect a final spasm of trouble upon the nation, that will point them towards God, and then the kingdom will be here.

A Final Look at the Situation

Some of the things we are going to summarize in this section, have already been discussed, but since we need to give a broader picture of what's going on, we are going to include some things again. One of the reasons that 1914 was originally looked at as a likely date, was the 1845 year parallel that we have mentioned already. This parallel gave the Bible Students, that lived before 1914, a template to look at, that showed several things, one of which was that there was going to be a judgement and separation of the false church system, from the true.

They saw that from 1874 to 1914 was 40 years, and that span of time, had matched a similar 40 year period in the Jewish harvest, which ended in 69 AD, with the destruction of Jerusalem. The beginning of that 40 was 29 AD, which was where Christ began his ministry. By careful study, it was determined that the 40 years in the time of Christ and the

events that happened there, were a parallel with the other 40 years, on this end of the age.

The parallel showed that judgment of the churches would start in 1878 AD, and it was also seen that a time of trouble would follow the 40 year period, of 1874-1914. This trouble was to destroy and punish the civil power that had been associated with the false church-state system, and it was predicted, by the parallel, that this would occur in 1914 AD.

End of Age Harvest Separation

It was also thought, by the early Bible Students, that those who were of the true church, but stuck in the false church system, needed to come out to the Lord during the 40 year harvest period or they would lose their crown or place in the 144,000.

Rev 18:4 I heard another voice from heaven, saying, "Come out of her, my people, so that you will not participate in her sins and receive of her plagues;

Matt 24:15-16) 15 "Therefore when you see the ABOMINATION OF DESOLATION which was spoken of through Daniel the prophet, standing in the holy place (let the reader understand),

16 then those who are in Judea must flee to the mountains.

The 144,000

The number 144,000, is spoken of in Rev 7:4, in which this is the number that is said to have been sealed in the forehead by God. It's not know for sure, if this number is symbolic, or an actual literal number. Most consider it to be an actual full number of elite saints, that the Lord is selecting, but since Rev is symbolic, some consider this number to be symbolic of the faithful church, and not an actual number?

The Great Company

This is the same chapter, Rev. 7, in which the other spiritual group, the great company, is shown to John. These two groups, are not literal Israelites, but are symbolic of both an elite faithful part of the church and another part which didn't do as good, but which are saved anyway, because of the blood of the lamb, Rev 7:14-17. See also Ezekiel 44:6-16, for a symbolic description of both of these classes.

The World

We also see a third class, called "the people", in that chapter, Ezk 44:11. They represent the earthly class, who are saved in the millennial age.

The Harvest

The harvest on this end of the age, was considered a parallel to the Jewish harvest, in which the Jews needed to accept the new wine, (doctrine) that was available. We see the same thing happening on this end of the age. **There was a much greater revealing of God's plan, that came at that time,**

than what was ever known before. This is the mystery of God that was predicted: Rev 10:7 but in the days of the voice of the seventh angel, when he is about to sound, then the mystery of God is finished, as He preached to His servants the prophets.

A Testing of Heart Conditions

Unfortunately, only a few believed the message at the time. As to the reasons why not, it probably varied from individual to individual. The Lord is looking at each individual's heart, and is testing us to see where our loyalties lie. Do we want to follow the Lord, or do we value our earthly institutions more? The seventh church of Rev 3:14, represents in symbol, the end time period that we are in now. It's thought that the seven churches in Rev chapters 2-3, in symbol describe 7 historical periods of the gospel age, from beginning to end.

For that reason we would see that the seventh church, applies to this end of the age, especially from 1878 onward. The Lord in the seventh church, wants us to invite him in to our hearts, so that he can sit down, and dine with us on spiritual food.

Rev 3:20-21) 20 "Behold, I stand at the door and knock; if anyone hears My voice and opens the door, I will come in to him and will dine with him, and he with Me.

21 "He who overcomes, I will grant to him to sit down with Me on My throne, as I also overcame and sat down with My Father on His throne.

If we invite him into our hearts, and follow him, he will give us spiritual food, that will strengthen us, so that we may be of those who are considered to be true wheat.

Separation of Wheat and Tares

We now see that since 1914 AD, we are in a final period of testing and final selecting for the church. This is just as we should have been expected from the scriptures, in that they indicate that we are in a time of separating, that will select the final members of the heavenly church, and reject the false ones.

One of those scriptural areas, is found in the parable of the wheat and the tares, the wheat represents true Christians that had came into existence, by the word of truth. See Matt 13:24-30, 36-43. Satan the enemy in the parable, went and sowed tares or weeds into the field of the world. The tares represent false or imitation Christians. A tare is different than wheat, in that it looks like wheat on the outside, but inside it doesn't have any seed or fruitage that is worth anything. As a symbol it represents false Christians very well, its head is empty of the fruity part of the grain.

Rather than root out the wheat with the tares, the Lord said that they would both be allowed to grow together, until the end of the age. At the end of the age, in the harvest, the

wheat would be separated from the tares, and the tares burned. We think that this separation occurred from 1874 to 1914, during the 40 year harvest that we just discussed.

A Final Gleaning After the 40 Years

Even though there was a 40 year period for the harvest, we think that the harvest still goes on, in the gleaning of the field. In ancient Israel, after the main harvesters had gone through, the field was gleaned for any wheat that they had missed. The Lord is still selecting replacements for those that he needs to complete, the church. Once that work is done, the gleaning will stop, and the millennial blessings will come.

After 1914 AD, we think that the Lord is dealing with individuals and not organizations. That's why we see Jesus in the seventh church, standing at the door and knocking, and wanting "us" to let him in, to sup with him. **This does not mean that we can't use a group or church to help us in our Christian walk, but if we do, we should be sure that what they are teaching, is in harmony with the bible! We don't want to wind up in the group that is described as weeping and gnashing their teeth, because they failed.**

We Are in a Replacement Phase

Since there are some that lost out and became great company, during the 40 year harvest, we see that they would need to be replaced, so that there will be a full number in the church. For that reason, the replacement phase of the harvest, will continue working with individuals, until the full number of the church has come in, and then the blessings of the kingdom can begin, first with Israel, and then with the rest of the world, including all those who sleep in death.

The Race For the Prize is Still On

We do not think that the door is shut, as some would like us to think. **For that reason, we encourage anyone who see these things, to run the race diligently, because the time is short!**

(Rom 11:25-27) 25 I do not want you to be ignorant of this mystery, brothers, so that you may not be conceited: Israel has experienced a hardening in part until the full number of the Gentiles has come in. 26 And so all Israel will be saved, as it is written: "The deliverer will come from Zion; he will turn godlessness away from Jacob. 27 And this is my covenant with them when I take away their sins."

The Burning of the Tares

We are now in the time of the symbolic burning of the tares, and that takes a certain amount of time to complete. The tares are not literally burned or destroyed, but in symbol their hopes and claims to be of the true church are destroyed. They did not build on the true foundation of Christ, so their chance for a reward is lost. In the 1 Cor 3: account, regarding the fire, even though we see that their works and reward

will be destroyed, they will still be saved, but as through fire, (great difficulty and pain).

(Matt 13:30) 30 Let both grow together until the harvest: and in the time of harvest I will say to the reapers, Gather ye together first the tares, and bind them in bundles to burn them: but gather the wheat into my barn.

*(Matt 13:40-43) 40 As therefore the tares are gathered and burned in the fire; so shall it be in the end of this world. 41 The Son of man shall send forth his angels, and they shall gather out of his kingdom all things that offend, and them which do iniquity; 42 And shall cast them into a furnace of fire: **there shall be wailing and gnashing of teeth.** 43 Then shall the righteous shine forth as the sun in the kingdom of their Father. Who hath ears to hear, let him hear.*

*(Matt 13:47-50) 47 Again, the kingdom of heaven is like unto a net, that was cast into the sea, and gathered of every kind: 48 Which, when it was full, they drew to shore, and sat down, and gathered the good into vessels, but cast the bad away. 49 So shall it be at the end of the world: the angels shall come forth, and sever the wicked from among the just, 50 And shall cast them into the furnace of fire: **there shall be wailing and gnashing of teeth.***

Some Have Lost their Crowns

Those who did not do correctly, lost their crown. In the scriptures, to have a crown, represents in symbol, having won out or proven faithful. There is of course the implication that if we do not prove faithful, we will not get the crown of righteousness, but someone else will get it instead. This would not mean second death, but it would imply that such a one would become part of the great company class, that did not prove faithful in all things. The scriptures show that the harvest would be a time in which many would be tested and separated out, into one class or another. *2 Tim 4:8 in the future there is laid up for me the crown of righteousness, which the Lord, the righteous Judge, will award to me on that day; and not only to me, but also to all who have loved His appearing.*

James 1:12 Blessed is a man who perseveres under trial; for once he has been approved, he will receive the crown of life which {the Lord} has promised to those who love Him. 1 Pet 5:4 And when the Chief Shepherd appears, you will receive the unfading crown of glory.

Regarding the Second Coming or Presence of the Lord

The Bible Students, have also presented an important new concept, regarding the second coming of the Lord, in that we see that at least the beginning portion of the return of **the Lord, does not have to be a literal return, as many believe. This concept, is not understood by most churches at this time, but we think that its correct.** The term "Second Coming" is not translated properly, in that the word coming can mean presence.

Matthew 24:3 [Coming] [parousias (grk 3952)]. Originally, "presence," from [pareinai] (grk 3918), "to be present." In this sense in <Phil 2:12; 2 Cor. 10:10>. Also "arrival," as in <1 Cor. 16:17; 2 Cor. 7:6-7; 2 Thes 2:9; 2 Pet. 3:12>. Of the second coming of Christ: <James 5:8; 1 John 2:28; 2 Pet. 3:4; 1 Thes 4:15> (from Vincent's Word Studies of the New Testament)

The Lord Comes as a Spirit

The word "coming" by itself, seems to give the wrong thought of how the Lord is going to return. If we use the term "present", it shows us a completely different possibility. **You can be present as a spirit, not having come bodily, and that is what we think has actually already happened, since 1874,** which is one of the dates we have already considered, in this book.

First of all, that date is the beginning of the seventh 1000 yr day and the Lord is the Lord of the sabbath or seventh day. Another reason, is the 40 year harvest parallel that we just considered. **Just as he came at the beginning of the first 40 years, we would expect him to come at the beginning of the second parallel 40 years, (See page 15).** While the Lord had been watching over the church, all through the age, this presence is different, in that he has come with the specific purpose to judge the church, and to establish his kingdom in power. This is a parallel to the first advent, when he judged the Jewish system, and established the gospel age.

Not a Literal Every Eye Shall see Him?

The "presence" part of the Lord's return, on this end of the age, is not necessarily the full coming, where we would say that every eye can see him, (Rev 1:7), but its a secret presence, where he has come to judge the church, and get prepared to begin the kingdom rule. There are actually several steps to the process of the coming of the Lord, some of which have occurred already.

Only the final step, will be where he will be seen or perceived by all. See volume. 2-3, of "the Studies in the scriptures", for more information on this.

Rev 1:7 Behold, He is coming with clouds, and every eye will see Him, even they who pierced Him. And all the tribes of the earth will mourn because of Him. Even so, Amen.

Even in the case of the final step of the coming to the world, its debatable if we will actually have a literal bodily coming, because the word "see" can actually means to perceive spiritually. [*Shall see*] [*opsetai (grk 3700)*]. *The verb denotes the physical act, but emphasizes the mental discernment accompanying it, and points to the "result" rather than to the "act" of vision. See the note at <John 1:18>. Appropriate here as indicating the quickened spiritual discernment engendered by the Lord's appearing, in*

those who have rejected Him, and who now mourn for their folly and sin. (from Vincent's Word Studies of the New Testament)

It Was Predicted the Lords Return Would Not be Known at the Second Coming!

If we were going to have a loud trumpet blast and the Lord seen in the heavens, literally coming, why do the scriptures tell us that most would not know it? We now at the present time, have a similar situation as what happened in the time of the Jewish harvest.

Just as the Jews didn't recognize the time of their visitation, neither do most churches now! *Luke 19:44 They will dash you to the ground, you and the children within your walls. They will not leave one stone on another, because you did not recognize the time of God's coming to you." Matt 24:39 And knew not until the flood came, and took them all away; so shall also the coming of the Son of man be.*

I Say Unto You All Watch

Most of the churches have forgotten that they should be "watching" for the Lords return. **If the return was to be a literal return, with an actual loud trumpet blast, there would be no need to watch, since the event would be obvious to even a blind person.** But if it's at first a secret return to the church, there would need to be a careful examining of the scriptures, and the signs of the times, in order to understand and recognize this.

Remember, the Lord was to return as a thief in the night! A thief in the night sneaks into the house very quietly, so that no one knows he is there!

1Thes 5:2 for you know very well that the day of the Lord will come like a thief in the night. (NIV)

(Matt 24:42-44) 42 Watch therefore: for ye know not what hour your Lord doth come.

43 But know this, that if the goodman of the house had known in what watch the thief would come, he would have watched, and would not have suffered his house to be broken up.

44 Therefore be ye also ready: for in such an hour as ye think not the Son of man cometh.

The Lord came secretly, so that he could break into the strong mans house. (Satan), and spoil his power base, the oppressive church and state system.

Midst of the Years and Proof of the Chronology in this Book

What we have seen in this booklet, is that the chronology that Bible students are familiar with, such as what we have just discussed, the 1845 yr. judgment parallels, the 1260,

2520 yr. dominion cycles, and the 2500 yr. Jubilee of restitution, are a part of a much larger pattern, than was at first realized. We have see that those patterns are symmetrical about the midst or center of the 7000 years of God's plan.

By placing it into a larger framework, that is symmetrical around the midst of the years, we see that it's not possible to move the chronology from where it was originally placed in the volumes, as some would like to do.

The Midst of the Years

The concept of the midst of the years, found on these charts, is described in Hab. 3:2, where he prays to God, that in wrath, he should remember mercy. He also asks God to revive his work, in the midst of the years, and that through the midst of the years, to make it his work known. **Hab. 3:2 O LORD, I have heard your speech and was afraid; O LORD, revive Your work in the midst of the years! In the midst of the years make it known; in wrath remember mercy. (NKJ)**

We have seen, that not only did God center his work about the midst of a 7000 year time period, but by so doing, he is able to show us his plan of restoring all mankind, by the end of the 7000 years. Since one man, Adam, sinned and convicted the entire race, it required only one man, Christ, to redeem or ransom all of mankind. *(Rom 5:18-19) 18 Therefore as by the offence of one judgment came upon all men to condemnation; even so by the righteousness of one the free gift came upon all men unto justification of life. 19 For as by one man's disobedience many were made sinners, so by the obedience of one shall many be made righteous. (KJV)*

Wrath and Mercy

The wrath or anger mentioned in the Hab. scripture, is not just the wrath that came against literal Israel, that the prophet was concerned about, but in the full sense, its the sentence that fell upon Adam in the garden, and through him all mankind. The mercy that Hab. prayed for, was not just for the literal nation of Israel, but will eventually include mercy to all mankind.

The full answer to Hab. prayer, (which is to all mankind), was answered by the sending of Christ the promised seed, who is carrying out the Divine Plan, by which all who are willing will be restored to perfection, by the end of the 7000 years. Gal 3:16 Now to Abraham and his seed were the promises made. He saith not, And to seeds, as of many; but as of one, And to thy seed, which is Christ.

As we study the patterns, we have see that God has had complete control of the events that have had an effect on his plan. Satan has been trying to defeat the plan, but as we examine history, we see that God has always been able to come out

the winner, no matter what. For example when Satan arranged the death of the Lord Jesus, he thought he had defeated Gods plan, but in reality he had helped it progress. Jesus dying on the cross, provided the ransom, as well as the means of testing, first for Christ, and since then for the gospel age church.

A Prayer Regarding this Work!

We pray that this work will confirm God's plan and its chronology to all that study it, and that it will increase their faith. Chronology is what allows us to discern the times and the seasons, and without it we would soon lose sight of other important doctrines that separate our beliefs from the great falling away, that many are trapped in at this time. We pray that Satan would be soon completely bound, and that all who are deceived by him will be released from his bondage!

(II Th 2:2-4) 2 That ye be not soon shaken in mind, or be troubled, neither by spirit, nor by word, nor by letter as from us, as that the day of Christ is at hand. 3 Let no man deceive you by any means: for that day shall not come, except there come a falling away first, and that man of sin be revealed, the son of perdition; 4 Who opposeth and exalteth himself above all that is called God, or that is worshipped; so that he as God sitteth in the temple of God, shewing himself that he is God. (KJV)

If any additions or corrections, occur to any of the readers, regarding this booklet, we would ask that we be notified, so that we can enhance its message.

Our Email address is

pmezera@inwave.com

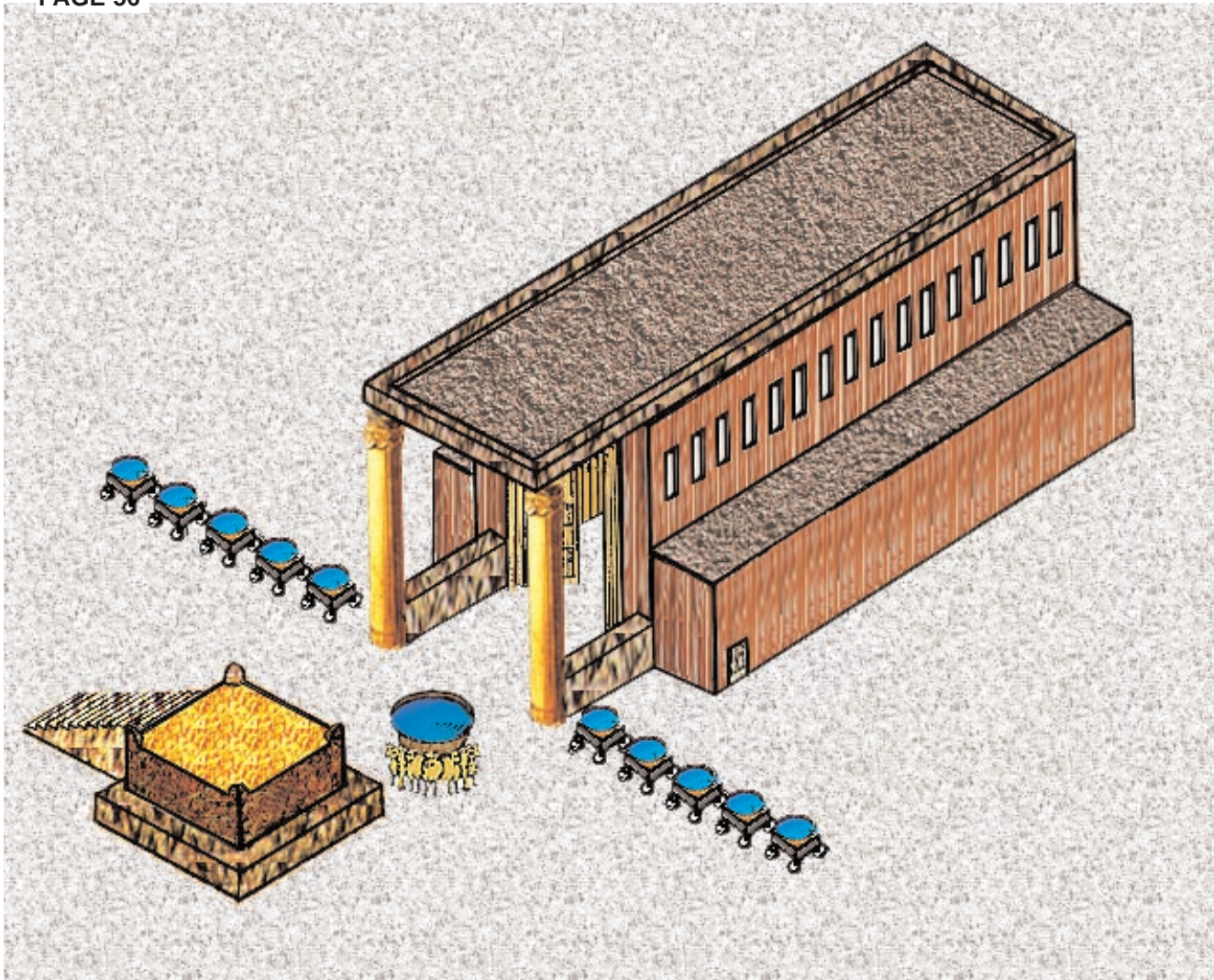

SOLOMON'S TEMPLE AND COURTYARD

The above picture, is a possible view of how Solomon's temple may have looked, when it was first built. This temple lasted until 607 BC, and the carrying away to Babylon. The temple was rebuilt, after the return from Babylon, by Zerubbabel. Herod then rebuilt it, just before the time of Jesus, making it double in size from its original plan. That temple was destroyed in 70 AD, by the Romans and has never been rebuilt.

Some think that it will be rebuilt as a third temple, in the next age, but we think that the third temple as portrayed by Ezekiel, is intended to teach us symbolic lessons. There will not be a need for a physical temple, in the kingdom, since Christ and the church will make up the symbolic New Jerusalem, that will bring Gods kingdom and salvation down to the earth and to the people.

We are going to next consider the dimensions involved in the different temples. We will show that God has inspired all of the Biblical dimensions, so that they confirm the Divine plan of the ages! We will see that the 25 inch cubit, ties all the different ages together, because only God could have supplied dimensions over hundreds of years, that would work in the same way.

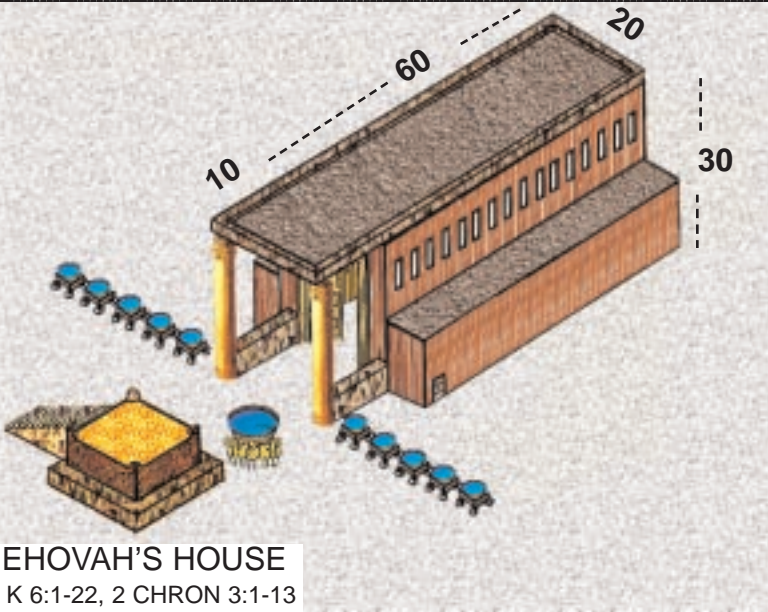

JEHOVAH'S HOUSE
1 K 6:1-22, 2 CHRON 3:1-13

$$\begin{array}{r}
 20 \quad 100 \\
 20 \quad \underline{X25} \\
 30 \quad 2500 \text{ YR} \\
 \hline
 30 \quad \text{TOTAL OF EACH} \\
 100 \quad \text{END OF MAIN} \\
 \quad \quad \text{HOUSE}
 \end{array}$$

$$\begin{array}{r}
 60 \quad 240 \\
 \underline{X4} \quad \underline{X25} \\
 240 \quad 6000
 \end{array}$$

TOTAL OF 4
LENGTHS OF
MAIN HOUSE

$$\begin{array}{r}
 70 \quad 280 \\
 \underline{X4} \quad \underline{X25} \\
 280 \quad 7000 \text{ YEARS} \\
 \text{TOTAL LENGTH OF} \\
 \text{HOUSE AND} \\
 \text{PORCH TOGETHER} \\
 \text{IS 70 CUBITS}
 \end{array}$$

4 LENGTHS OF THE END OF THE PORCH = 40
 2 HEIGHTS OF ONE END OF PORCH = 40
 2 HEIGHTS OF PORCH = 40
 2 WIDTHS OF PORCH = 40
 2 WIDTHS OF HOUSE = 40
 40 X 25 = 1000 YEARS

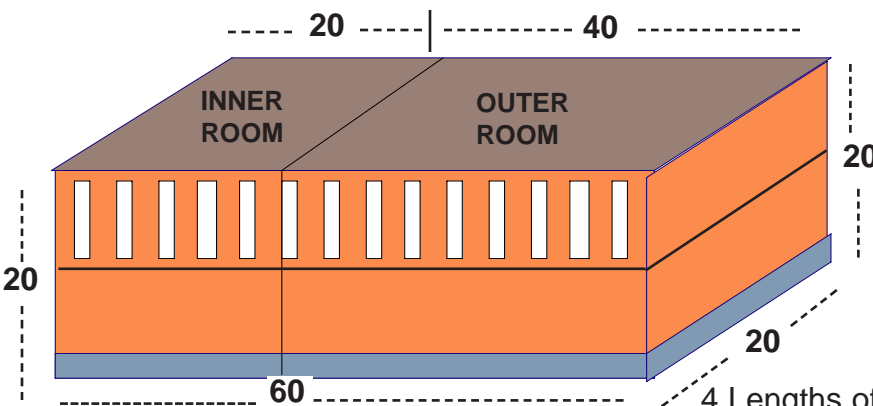

THE LORD'S HOUSE 1
KINGS 6:14-22, 1 CHRON 3:8-9

In the inner room any 2 lengths, any 2 widths and any 2 heights equals 40 cubits. In the outer room any single length, any 2 widths and any 2 heights equal 40 cubits.

4 Lengths of the rooms are 4 x 60 = 240 cubits.

$$\begin{array}{r}
 40 \\
 \underline{x25} \\
 1000 \\
 \\
 240 \quad 6000 \\
 \underline{x25} \quad \underline{1000} \\
 6000 \quad +7000
 \end{array}$$

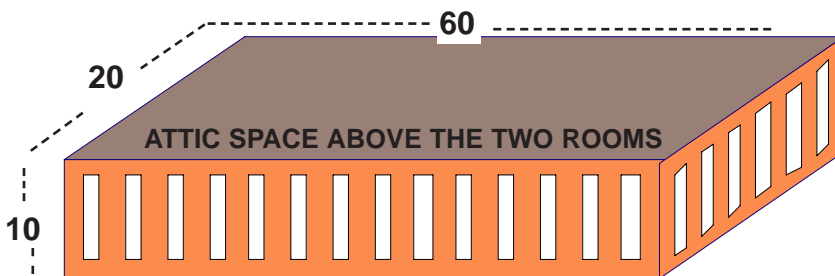

4 HEIGHTS = 40 CUBITS
 2 WIDTHS OF 1 END = 40
 40 X 25 = 1000 YEARS

$$\begin{array}{r}
 25 \times 240 = 6000 \text{ YEARS} \\
 \text{ADDING} \quad \underline{1000} \\
 \quad \quad 7000 \text{ YEARS}
 \end{array}$$

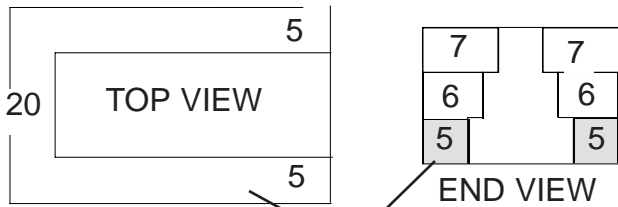

GROUND LEVEL SIDE CHAMBERS

SIDE CHAMBERS

1 KINGS 6:5-8

One end of a side chamber, is $5+5+5+5 = 20$ cubits.

Both lower ends = 40 cubits. $40 \times 25 = 1000$ yrs.

Total width of one chambers = 20.

Two widths = **40 or 1000 yrs.**

Four lengths of a chamber side = 60×4 or $240 \times 25 = 6000$ yrs.

BRONZE TEMPLE PILLARS BOAZ AND JACHIN

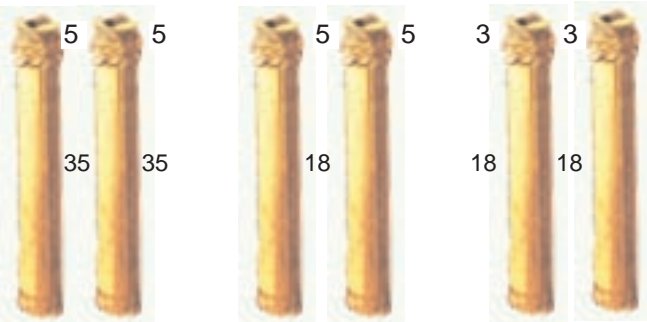

2 CHRON
3:15-17
ADAM CHRIST

1 KINGS
7:15-22

1 KINGS
25:17

The three sets of pillars to the left, are the same pillars, but the dimensions are different in the three scriptural texts where they are given. The II Chron pillars are 40 cu tall apiece, where the ones in 1 Kings, give you 40 only if you add the "total" dimensions, as given. In the case of the other pillars $40 \times 25 = 1000$ years.

The two sets of pillars on the right, would fit with the temple dimensions better, than the one on the left. The temple was 30 cubits high, so the shorter ones would have fit under the roof height, for the porch where the ones on the left would have been higher. One suggestion given for the different dimensions, was that there may have been remodeling or repair?

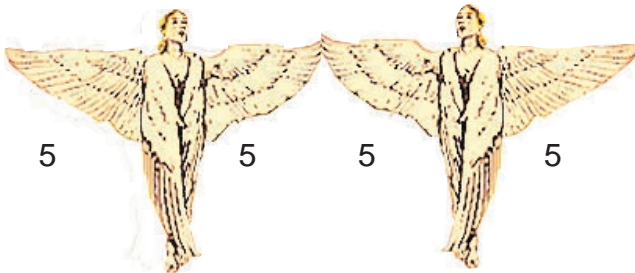

TWO CHERUBS

TOTAL DIMENSIONS OF THE TWO CHERUBS = 40. WE TAKE $40 \times 25 = 1000$ YEARS.

1 KINGS 6:23-28, 2 CHRON 3:10-13

In Gen 3:24, God placed the two Cherubs with the flaming sword, to block the way to the tree of life. In the wilderness tabernacle, the Cherubs face inward, because justice was not satisfied yet. Solomon's temple shows a further progression of Gods plan, in which they are turned forward, ready to bless, because the bullock's blood has been placed on the mercy seat by Christ's sacrifice. Only the church can receive the blessing now, because only they can go into the most holy, but when the church is complete, (the goat of the sin offerings blood placed on the mercy seat), the Cherubs will be released, so that they can fly to bless the world! The Cherubs are not found in Ezekiel's temple, because they will have flown at the completion of the church. At that time the tree of life will again available, to the world (Rev 22:14, 19).



MOLTEN SEA
1 KINGS 7:27-39

The molten sea was 30 cubits around, and 10 across. It also sat upon a base, that was 5 cubits high. The 30 and 10, added together, equal 40. Again $40 \times 25 = 1000$ years. Respecting the dimension of 5 cubits, we don't know for sure what it is. We observe that **5 cubits** is found in other places in the tabernacle, and it **would equal 125 years!**

2 WIDTHS OR LENGTHS = 40 CUBITS
4 HEIGHTS = 40 CUBITS
 $40 \times 25 = 1000$ YEARS

COPPER ALTAR

2 CHRON 4:1

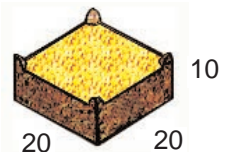

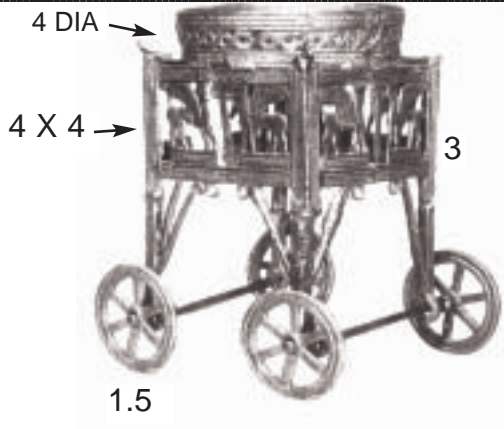

Each laver was 4 cubits apiece. $4 \times 25 = 100$ years.
 10 Lavers at 4 cubits a piece = 40 cubits $40 \times 25 = 1000$ years.

Each side of the laver that had wheels on it, was $4+4+3+3$ or 14 cubits. The two sides = 28 cubits per laver. Ten lavers totals 10×28 or 280 cubits $280 \times 25 = 7000$ years.

The white stand or base under the laver is .5 high. Total height of ten bases, for ten lavers equals 5 cubits.

$5 \times 25 = 125$ years. The tabernacle as well other cubit based dimensions in the Bible, seems to be made up of 125 yr units.

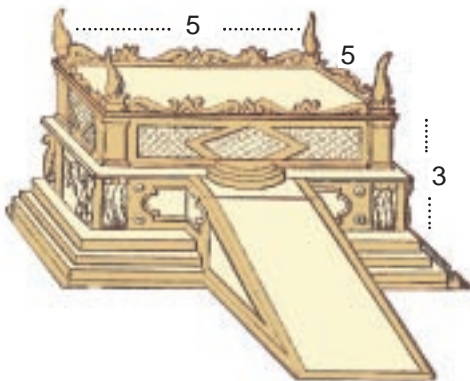

SOLOMON'S BRONZE SCAFFOLD 2 CHRON 6:13

The total of the top and the bottom of the scaffold, is equal to 40 cubits, $40 \times 25 = 1000$ yrs.

The cast supports were 1 cubit high, and they were 1.5 in dia. The total dimensions of the wheels add up to 4 cubits.



$1.5 + 1.5 + 1 = 4$ cubits.

$4 \times 25 = 100$ years.

CAST SUPPORTS AND WHEELS

Each length of the house is 100 cubits. The two widths of the front and the back wall, total up to 100 cubits per wall. Two lengths of the roof or the floor of the porch, equals 100 cubits. $100 \times 25 = 2500$ years.

The 4 verticals of the main house = 120 cubits. The 4 widths of the porch equals 120 cubits. Together this equals 240 cubits, $240 \times 25 = 6000$ years.

The height of the porch is not given, and we assume that it is the same height as the porch on Jehovah's house.

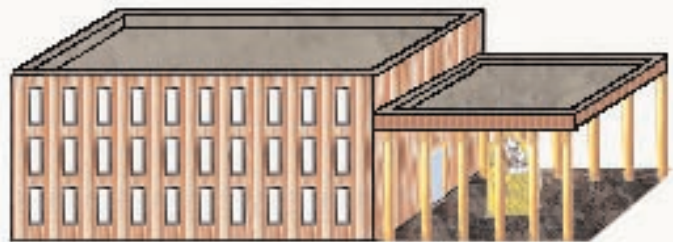

THE HOUSE OF THE FOREST OF LEBANON 1 KINGS 7:2-12

Solomon's temple was built at least 500 years after the tabernacle of the wilderness, yet it still teaches the same lesson through the 25 inch cubit. All of the dimensions still show the same plan of the ages, and the chronology that supports it.

Even though Solomon's temple shows us a further progression in God's plan and more detail than the wilderness tabernacle, the plan has not changed. This again confirms that God has been controlling his plan down to the smallest detail, all through the ages !

----- 500 CUBIT SQUARE -----

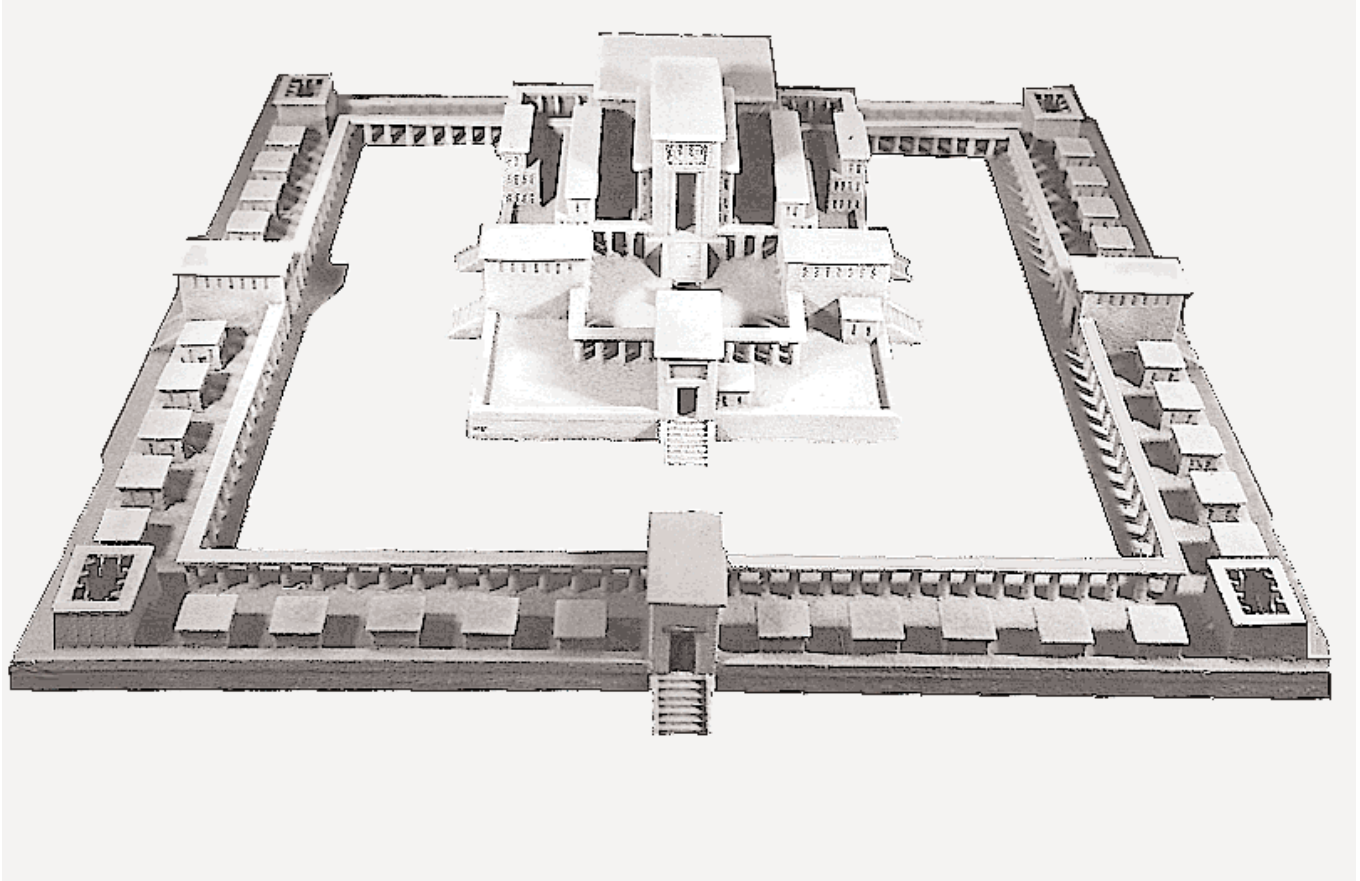

EZEKIEL'S TEMPLE

Ezekiel's Temple Confirms the 2500 Jubilee

Ezekiel's temple, also confirms the Divine Plan of the ages, and the chronology associated with it. Any of the dimensions that are 100 cubits, such as the width of both the inner and the outer court, equals **100 x 25 or 2500 years**. These numbers confirm the Jubilee cycle and restitution available for all mankind.

The altar labeled A, is centrally located in the temple, just as Christ's sacrifice is central to God's plan! The court yard that it is located in, is dimensioned 100 cubits. **100 x 25 = 2500**. This again shows that restitution as pictured by the jubilee is central to Gods plan, and that it comes from Christ's sacrifice. There are no Cherubs in Ezekiel's temple because they will have flown forth to bless the people when the church is complete.

1000 and 6000 Years

The 4 kitchens labeled K, are 40 by 30 cubits. Each length of 40, is **25 x 40 or 1000 years**. The widths of all 4 kitchens taken together, are **8 x 30 or 240 cubits, 240 x 25 = 6000 years**

The 30 chambers around the lower pavement are not dimensioned. The people symbolically come into the court and the lower pavement and into these chambers, to feast on the good things of God, in the kingdom. That these chambers are not dimensioned, indicates that the opportunity for salvation in the kingdom, will be unlimited. Any person who will accept God's plan, will be able to enter into the temple and receive salvation and feast on the good things found there.

In some applications, its possible to use 1 cubit per year, in order to find applications that point to Gods kingdom. The outer dimensions of the wall around the temple court, are 500 cubits on a side, and any two sides together equal 1000 years.

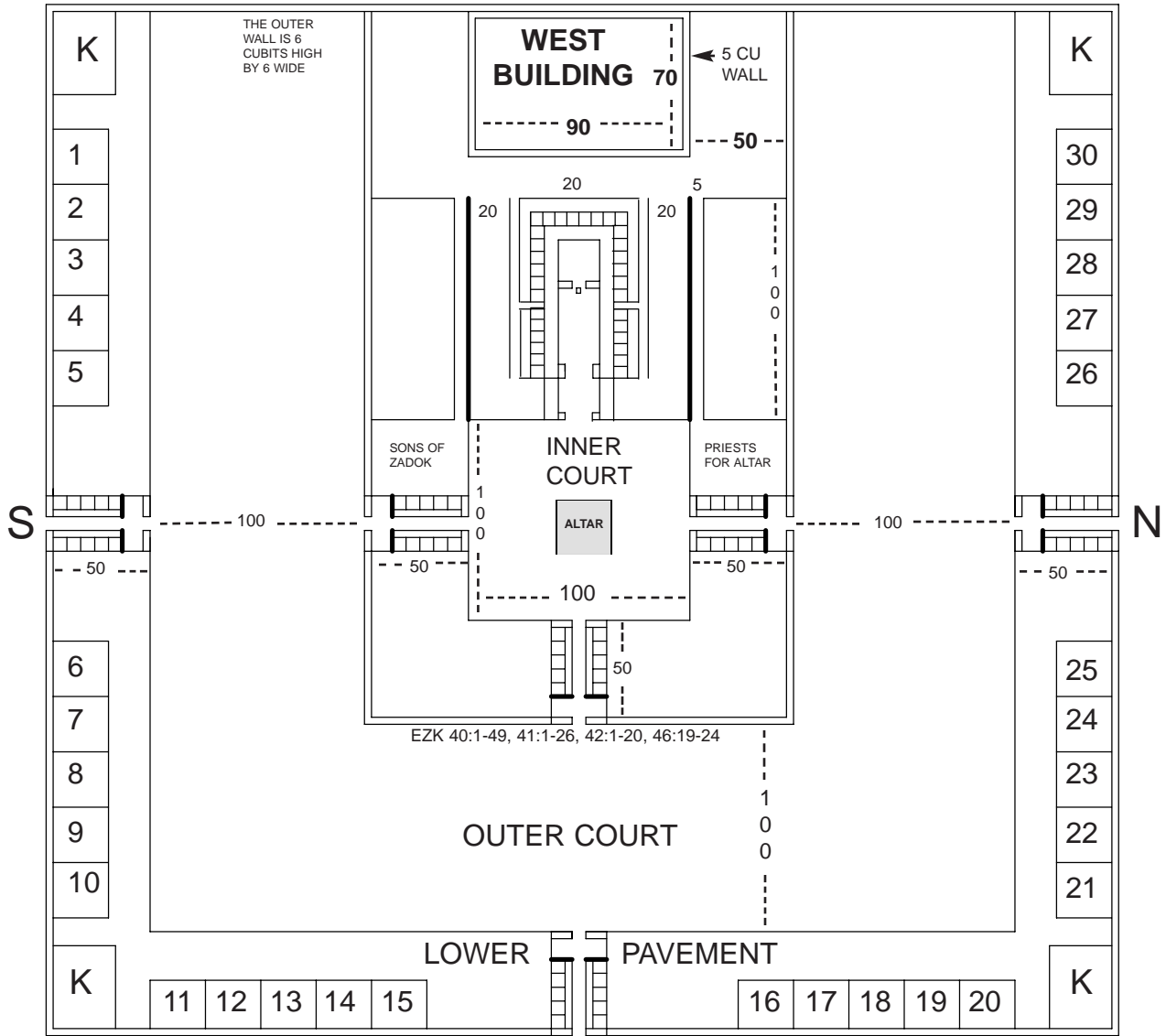

The King Comes In Glory

In Ezekiel 43:4-7, we are shown the Lord coming into the temple, and it being filled with his glory. This would be a picture of the time, after the door is shut and the church is complete. In verse 7, he tells us that this is where the seat of his power and the resting place of his feet will be, and that he will be among the Children of Israel for ever. At that time, the Children of Israel would no longer make his name unclean, and that they will be ashamed of their ways, Ez 43:10-11.

The Earthly Kingdom

This is the earthly kingdom, when all will have to become Israelites, and put away all practices that are not in harmony with Gods laws. The glory of the Lord coming in to the temple, is after the church is complete and when the kingdom starts. **The door from the east, represents the way that is open to the high calling, and after the Lord enters in, it is shut, and it will not be reopened, (Ezekiel 44:1-3)!**

Faithful and Unfaithful Levites

If you read Ezekiel 44:4-16, you will find that there were both

faithful and unfaithful Priests. The Levities who went astray, represent the great company, who are not allowed to come before God, to do the work of priests.

We are told many of the things that they did wrong, in symbol, and this should become a detailed study for us, so that we don't wind up in that class. We ourselves should be careful, that we don't have any symbolic or actual idols, that we need to remove.

In Rev 7:9, 14, the great company is shown before the throne, and but not on it. They still are able to receive salvation, but only because of the blood of the lamb! They are a spiritual class, but they are failed priests, and can only serve as gate keepers, and temple servants, for the people and the care of the house, Ezk 44:10-14.

The Faithful 144,000

The faithful sons of Zadok, represent the 144000, and they are allowed to come before God, Ezekiel 43:15. In Rev 14:1, they are shown on mount Zion, with the lamb. Only the church is allowed to be on the throne. They have proven themselves to be more than overcomers, and they receive the crown of life.

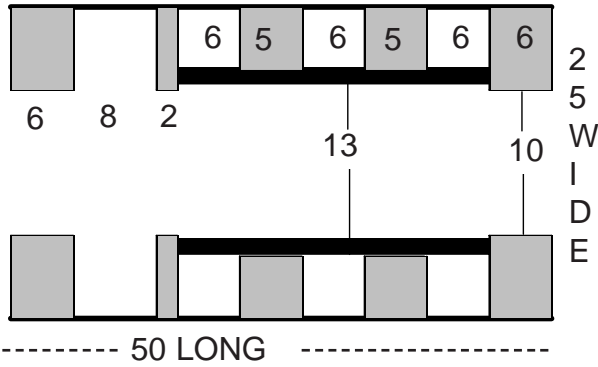

Two lengths of the gateway, equals **100 cubits or 2500 years.**

The text in Ezk 40:14, about the pillars is not clear, so we have not included it in this drawing. There are at least 3 different interpretations, depending on the translation.

We favor the one that says the pillars were 60 cubits high, since 4 pillars are equal to, **(4 x 60 or 240 cubits). 240 cubits times 25 inches = 6000 years.** We hope the dead sea scrolls shed some light on this dimension later.

The inner gateways, are the same dimensions as the outer gates, except they are reversed, end for end.

TEMPLE GATEWAY

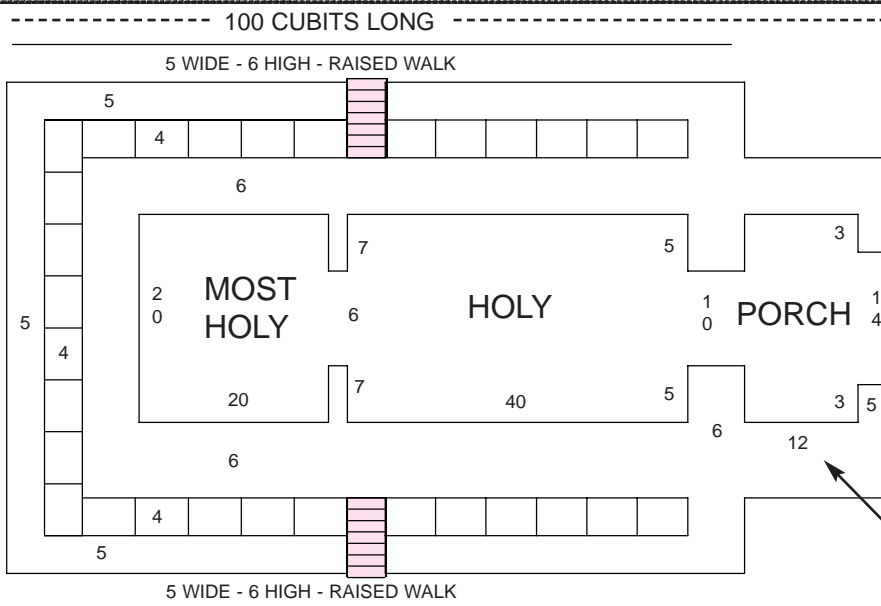

Each length of the temple is 100 cubits, **(100 x 25 = 2500).**

Two widths of the ends = 100 cubits total, **(100 x 25 = 2500 yrs).**

2 lengths of the most holy, or 1 length of the holy = 40 cubits, or **40 x 25 = 1000 years.**

The King James Bible gives 11 for the length of the porch, but this leaves the length of the building 1 cubit short. The new Jerusalem Bible says 12 cubits, and this makes the temple length 100 cubits, **100 x 25 = 2500.**

EZEKIEL'S TEMPLE BUILDING

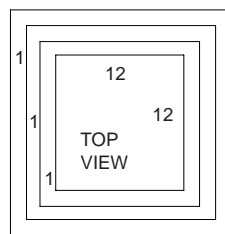
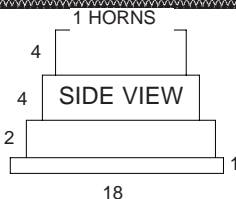

THE ALTAR

EZK 43:13-17

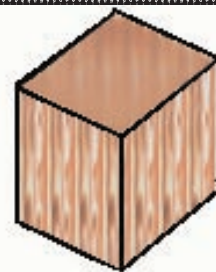

WOOD TABLE
EZK 41:22

The heights of the 4 corners of the altar, without the base and the horns, are 10 x 4 or 40 cubits, **(25 x 40 = 1000 years).**

The 4 sides of the base, or the 4 horns of the altar, add up to 4 cubits apiece, **(4 x 25=100).**

The altar is shaped like a step pyramid.

The 12 cubit square on the top, is 12 x 12 or 144 sq cubits. This suggests the 144,000 of the church. We also get **100 + 40+ 4, which = 2500, 1000, and 100 years.**

The 4 horns and 4 heights of each side of the base, = 4 cubits, **4 x 25= 100.**

Each side of the wood altar is 10 cubits, (2+2+3+3). 4 sides = 40 cubits **(40 x 25 = 1000 years).** Any 2 lines of the top or the bottom, = 4 cubits or **4 x 25 = 100 years.**

Each side of the altar, totals 10 cubits, (2+2+3+3). 4 Sides = 40 cubits **(40 x 25 = 1000 yr).** Any two lines of the top or the bottom = 4 cubits or **4 x 25 = 100 years.**

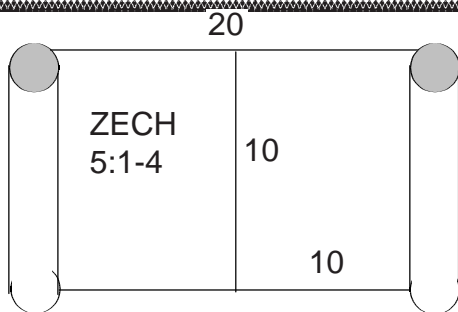

THE FLYING SCROLL

The flying scroll from Zech 5:1-4, is 20 x 10 cubits. Two lengths are equal to 40 cubits. In Biblical times, scrolls were rolled up from each end, in two halves. Each half is equal to 40 cubits, (**40 x 25 = 1000 years**). These pairs of 1000 yrs, could be referring respectively to Adam’s day and Christ’s day. What Adam lost in the first day, will be restored in the second day. One other possibility, could be an overlapping millennium?

Zech 5:3 It says that “this is the curse going out over the whole land; for according to what it says on one side, every thief will be banished and according to what it says on the other, everyone who swears falsely will be banished”.

At the end of the Gospel age, and the beginning of the millennial age, all those who have tried to enter in by some other way, than by Christ, are the “**thief**” who will be cut off! *John 10:1”Truly, truly, I say to you, he who does not enter by the door into the fold of the sheep, but climbs up some other way, he is a thief and a robber. (NAU)*

At the other end of the millennial age, “**all those who swear falsely**”, or claim that they love the kingdom, when they really don’t, will be cut off in the little season, Rev 20: 7-9!

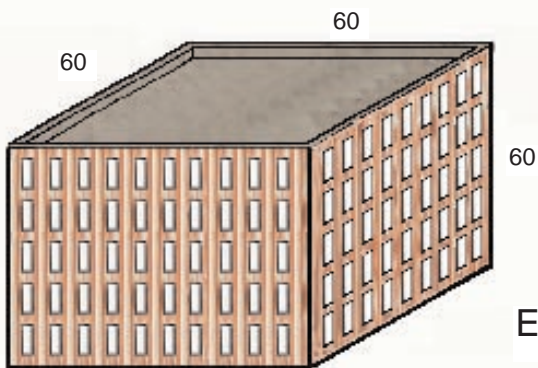

ANY OF THE 6 FACES OF THE HOUSE HAS A TOTAL OF 60 X 4 OR 240 CUBITS. **240 X 25 = 6000 YRS.**

EZRA’S NEW HOUSE OF THE LORD EZRA 6:3

Cities of Refuge

The description given in the text is unclear, but it appears that the suburbs of the city, are 3000 cubits on a side. At a cubit per year, this is 3000 years on a side, or 6000 years. The city in the center, would then represent the New Jerusalem, that is coming down from heaven in Rev 21:2-5. This we understand to be 1000 years, even though it is not dimensioned here. That would make the distance across 7000 years !

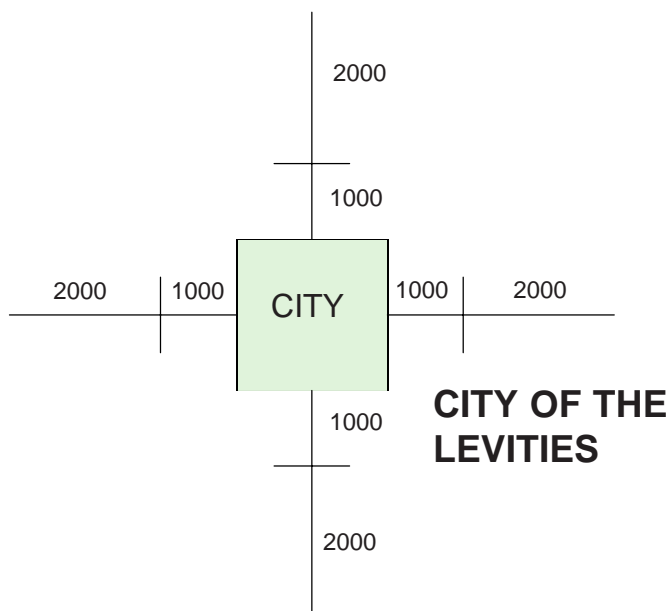

Seven Cities?

There were to be 6 cities of refuge, for the Levities, as given in the law. If we count New Jerusalem as one, we have 7 cities. We have no permanent city here ourselves, but we look to the new Jerusalem which is above, Gal 4:26.

Noah's Ark Gen 6:14-16

The waters were 15 cu over the tops of the mountains. Gen 7:20

$(15 \times 25 = 375$

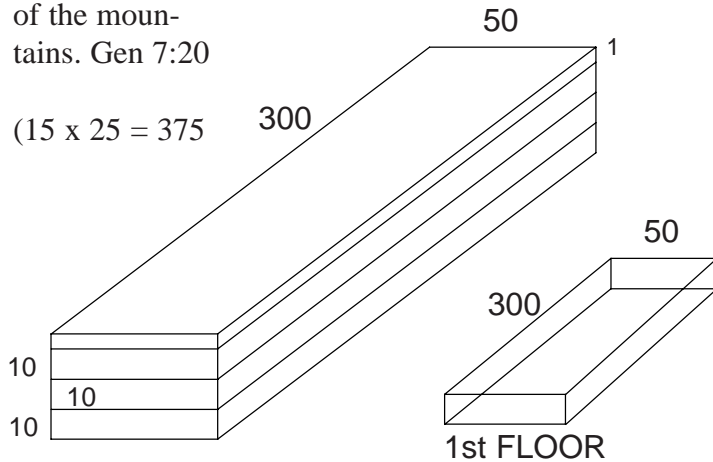

The two widths of each end of each floor, add up to 100 cubits, $(25 \times 100 = 2500$ years).

The total height of the 4 corners of the windows, = 4 cubits, $(4 \times 25 = 100$ years). Isa 65:20.

We think its likely that what the Bible describes here, is only the living area of the ark. Boats generally have a keel under them, but we have no way of knowing this for sure. The boat would have floated just the way it is described, so it may or may not have had a keel or a peaked roof? We will have to ask Noah in the kingdom.

THE IMAGE OF THE THREE HEBREWS

6x6x60

The image of Nebuchadnezzar, that the three Hebrews refused to bow down to, is similar to the Washington monument in shape. The description found in Daniel, says that it was **60 cubits high**, by 6 in breadth. We believe that this is **6 x 6 square**, and not round. The word is Strong's # 6613 and it means "width".

Total of Two Ends at 25 x, Plus Height at 1x =1260!

The total cubits of one end, is 4×6 or 24 cubits $(24 \times 25 = 600$ years). We haven't used the application of 1 yr per cubit in most places because it would add a lot of extra pages to the material being presented, but we believe that this is a valid place for it. Adding **the 600 years that one end equals, the 60 years of the length and the 6 years of the breadth at a cubit per yr we get 666 or the number of the beast!** Adding **the 600 years of the two ends together we get 1200 years. At a yr per cubit the height would be 60 years $(60+1200 = 1260)$!**

The Total Height = 6000 Years

The height is 60 cubits, and the 4 lengths of the 4 corners of the image, add up to 60×4 , or 240 cubits. Thus **25×240 cu = 6000 years!** The numbers involved in this image, seem to show that the kingdom of Satan, would begin to be restrained after the 6000 years, represented by its height, (1874 AD). The 1260 as we know, falls within the time span of the 6000 years of the height, (539 AD - 1799 AD)..

Satan Begins to be Restrained After 6000 Years

We also believe that this indicates the main power of the 666 of the image of the beast, should fall within the same time span of 6000 years. We are not saying that Satan is completely bound by 1874 AD, or that the false church system does not still exist, but they have had much less power, after 1874. It still remains to be seen, if they will regain the power to persecute before they expire.

This is in agreement with the angels statement, in Dan 12:6-13, that the river of trouble on his people, would be for 1260, 1290, and blessed is he that comes to the 1335 day, (1874 AD or the end of the 6000). The full binding of Satan and the destruction of his system, has to wait until the completion of the church, but Christ is restraining him, so that the church can be completed.



5
0
C
U
B
I
T
S

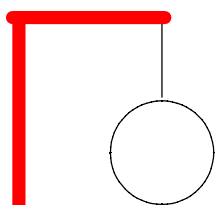

THE GALLOWS
ESTER 5:14, 7:9

The French Revolution

The gallows was 50 cubits high, (50 x 25 = 1250 yrs).
If we add 1250 years, to 539 AD we get **1789 AD** which was the date of the French Revolution. See the Bible Student reprints, 3574-3575.

Haman, a Picture of Papacy

Haman was hanged on the gallows, that he had intended for Mordecai. This is exactly what happened in symbol to the Papal system. They intended to do away with the reformation and the true church, but instead the French Revolution, marked a major turning point in their downfall. What they had intended for the church, happened to them instead, and they lost all their temporal power after that time. They gained some of this power back later, but only temporarily, and they have never gotten back to what they had before.

<p>100 X 25 = 2500 50x50=2500 Jubilee</p> <p>40 X 25 = 1000 Millennium</p> <p>4 X 25 = 100 Isaiah 65:20</p>

144 CUBIT
THICK WALL

100
40

4
144

THE WALL OF NEW JERUSALEM

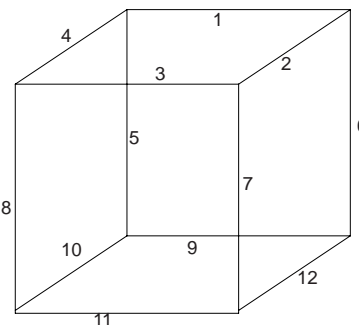

The city was 12000 furlongs in length, width and height.

The city is made up of 12 dimensional lines
(12 x 12000 = 144000!,
Rev 21:16

NEW JERUSALEM

The River of Water in Ezekiel at a Cubit Per Year?

The river of water that Ezekiel saw proceeding out of the temple, seems to show the progressive nature of Gods plan. Each step, represents a further progression of the plan. **If each cubit were to equal a year, this would be 4000 years.** 4000 years from the birth of Abraham, would bring you to the year 1880, or from his conception in the womb to 1879!

Where Do We Start Counting From?

The big question that we have about this type of application, is where to start counting the 4000 years from. The covenant with Abraham was made at age 75, and the birth of Isaac was at the age of 100. If you have to wait until the death of the one who made the covenant, (Heb 9:16-17), Abraham died when he was 175 years old, and 4000 yrs would reach to 2054.75 AD. The truth of this matter, probably lies somewhere in this time area, and while we can't get any firm dates from this prophecy, we can see that we are definitely in the end of the age.

About 2000 Cubits Behind the Ark!

In Joshua 3:2-5, the people were instructed to follow the ark, at a distance of about 2000 cubits. From the time of Christ until now is not quite 2000 years, but again it says about 2000 cubits, so we have no exact date confirmed! Both of these prophecies, show us that we are in the end of the age, but they do not give us the exact end date, (Acts 1:6-7). We now know much more about the times and seasons than the early church did, but we still do not know the exact start of the kingdom and the close of the church!

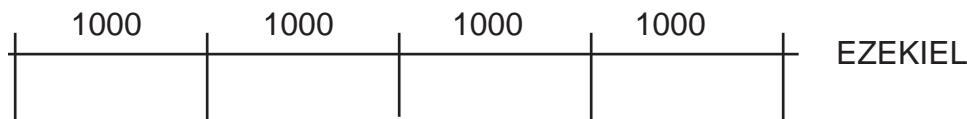

TWO RIVERS OF WATER

NORTH

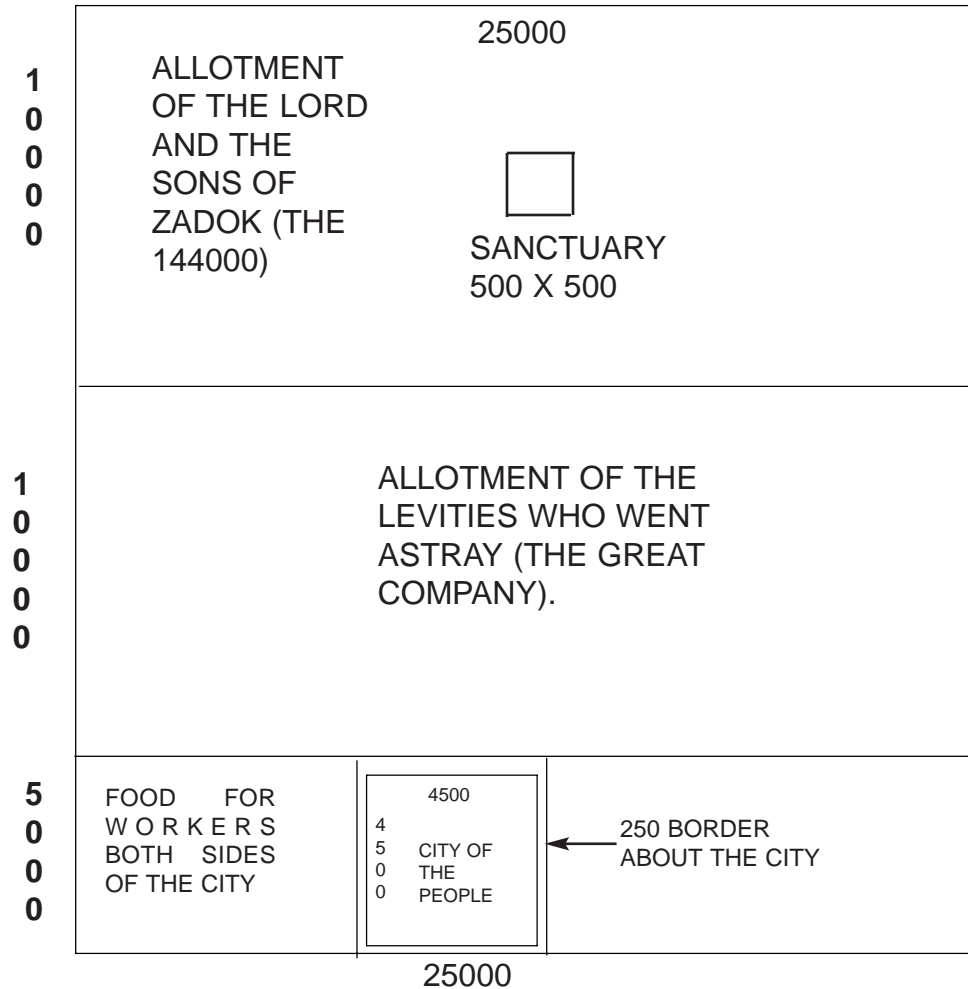

Ten Cubits Per Year?

At 10 cubits per yr, the 25000 cu of the border, becomes 2500 yrs, or the Jubilee cycle. In this case, we divide the number by 10, for example $25000/10 = 2500$.

The 10000 cubit width of each section, becomes **1000 yrs.**

The 250 cu border about the city, becomes 25 yrs. **4 sides x 25 = 100 yrs** (Is 65:20)

At one cubit per year, the 250 cu border around the city, would add up to **1000 years.**

The 4500 cu of the city becomes, 450 yr at ten cu per year. Two lengths or two widths add up to 900.

The width of the area of food for the worker, is $10000/10 \text{ cu} = 1000 \text{ yrs.}$

AT A CUBIT PER YEAR TWO LENGTHS OF ANY SIDE ADD UP TO 50000 OF THE GRAND JUBILEE !

EZK 45:1-6 AND 48:8-35

The order of the division of the land, shows the different salvations involved in the kingdom.

The Lord and the Church

The first division is for the Lord and the church, sons of Zadok.

The Great Company

The next is for the failed Levities, who represents the great company.

Ancient Worthies and the People

The last area is the city and this city is for the Ancient Worthies and for the people. This represents the earthly phase of the kingdom.

Another Lesson?

We have previously mentioned the chronology associated with the 500 cubits of the sanctuary area. We think that the 500 cubits, also gives us a another lesson at 10 cubits per year, since it is mentioned a second time, in relationship to the dividing of the land, see also Ezk 45:1-6, 48:8-35. **The 500/10 cubits would become 50 years and any 2 sides would be 100 yrs.** The 50/10 cubit border would become 5 yrs on a side ?

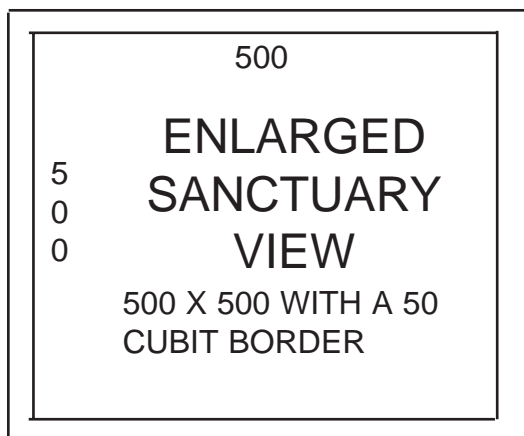

QUAIL WERE 2 CU DEEP

2 X 25 = 50 OR ONE JUBILEE CYCLE



DEPTH OF QUAIL
NUM 11:31

KING OG'S BED

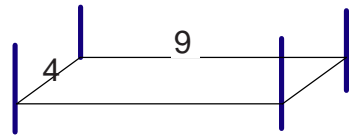

DEUT 3:11



HEIGHT OF GOLIATH
1SAM 17:4 = 6 CUBITS AND A SPAN

At present we don't know for sure the significance to the three sets of cubits at the left, unless you count the 4 cubits of the width of king Og's bed, $4 \times 25 = 100$ years. The 2 cubits of the plague of quail, could point to the Jubilee. This would show that even though the Israelites were killed by the plague, they will still be restored by the Jubilee or the time of restoration!

Since king Og and the warrior Goliath, were heathen, it could be that these cubits don't apply to them. In other words, these were not dimensions given by God, so it may be we shouldn't use them?

200 CUBITS FROM SHORE

JOHN 21:8
THERE ARE TWO 100 CUBIT LENGTHS
 $100 \times 25 = 2500$ YEARS

NEHEMIAH 3:13 REPAIR OF WALL

1000 CUBITS

When Nehemiah repaired the wall he repaired 1000 cubits of its original length. **At a year per cubit this would be 1000 years.**

400 CUBITS

2 KINGS 14:13, 2 CHRON 25:23

There are four 100 cubit lengths in the wall of the city as described by Nehemiah ($25 \times 100 = 2500$).

TRADITIONAL TABLE OF YEARS

ADAMS FALL—	4126.25 BC	
		1654 YR
START FLOOD—	2472.25 BC	
		427 YR
ABRAHAM COV-	2045.25 BC	
		430 YR
THE LAW—	1615.25 BC	
		46 YR
DIV CANAAN—	1569.25 BC	
		450 YR
JUDGES—	1119.25 BC	
		513 YR
KINGS—	606.25 BC	
		70 YR
TO END DES—	536.25 BC	
		536.25 YR
DATE—	0	
		1873.75 YR
OCT 1874—	1873.75 AD	
		1000 YR
OCT 2874—	2873.75 AD	
TOTAL—		7000 YR

Non traditional would add 19 for Joshua and take 19 from the time span reaching from the destruction of the temple, until the return from Babylon.

S	2300 DAYS ADDITIONAL FEATURE OF THE 2300 DAYS?	1	S
3 P		9	P
3 R		6	R
3 I		6	I
7 N		2	N
7 G		2	G
5 3		5	1
B 3		5	9
C 4		A	6
C		D	7

2300 Days to 1967 AD!

The vision in Dan 8:, was of Alexander the Great, conquering the Medes and the Persians. The question asked, was how long a time was the impiety, which caused the desolation, of **both** the **holy place** and **the fairest of all the lands**. The cleansing of the holy place, (church) is the first feature of this scripture, (volume. 3 page 95-120, "Studies in the Scriptures").

Fulfillment for the Church and for Israel

If we count 2300 years, from the time that Alexander invaded Asia Minor, in 334 BC, which led to his victory over the Persians in 331 BC, we arrive at the Spring of 1967, which is very close to exactly when Jerusalem was restored! This second feature of Jerusalem being restored, is an important part of the literal land of Israel being restored. These two interpretations give us both a symbolic and a literal interpretation of this time feature!

CHRONOLOGY OF THE PYRAMID

In that day there shall be an altar to the Lord in the midst of the land of Egypt and a pillar at the border thereof to the Lord and it shall be for a sign and a witness unto the Lord of Host in the land of Egypt; for they shall cry unto the Lord because of the oppressors, and he shall send them a savior and a great one, and he shall deliver them. Isaiah 19:19-20

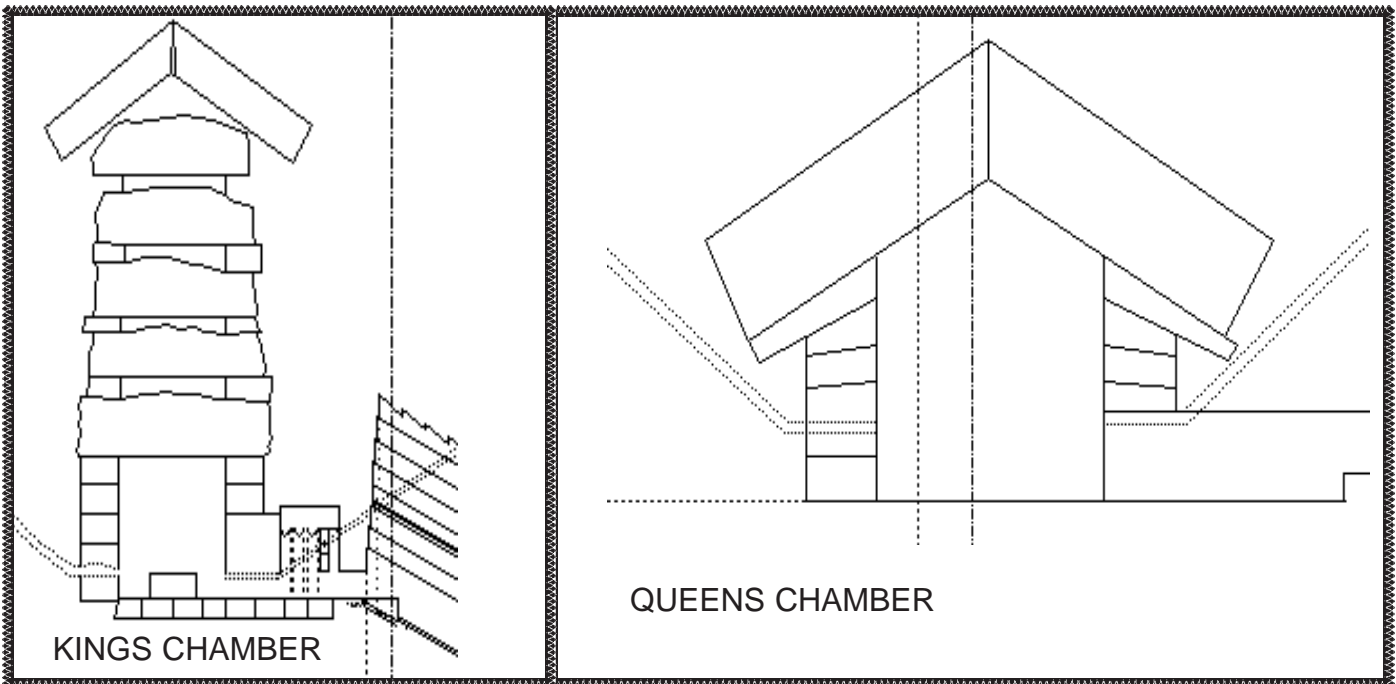
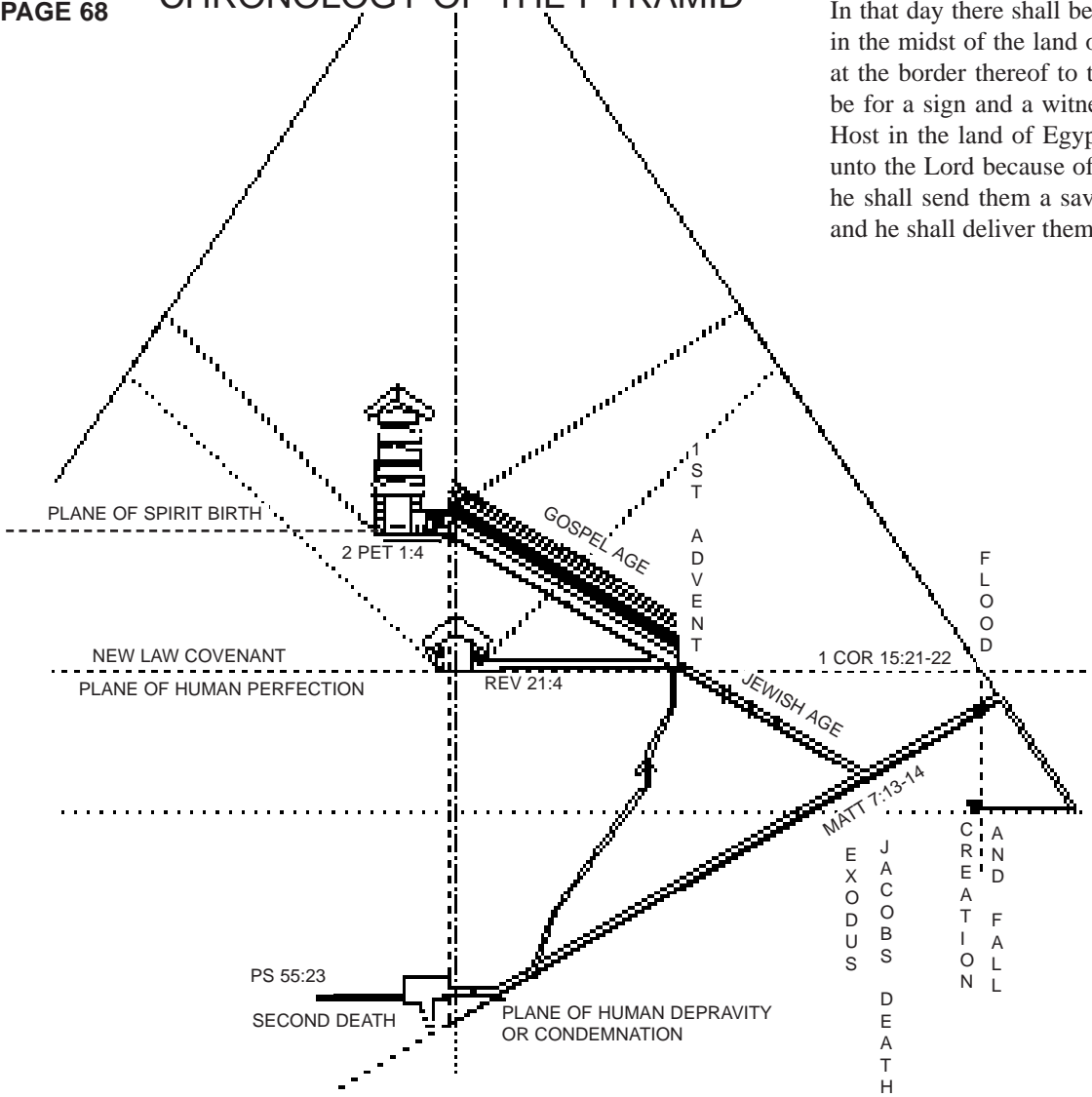

The following pages on the pyramid are not intended to be a complete work on the subject. For that, we recommend the third volume, of studies in the scriptures, and Edgar's book on the great pyramid. The only problem with Edgar's book, is that it is quite lengthy, involved and hard to sort out the basic chronology involved. Our intention is to try to condense the basics down into an easier to understand form, and to show that the calculations are exact, or nearly so. The method of dating in the pyramid, is related to the 25 inch cubit, but you would understand it better, if we tell you that we count a year per pyramid inch. A pyramid inch is not a British inch, but is very close, so for purposes of discussion, we will ignore the difference.

The Pyramid Demonstrates the Divine Plan

The great pyramid demonstrates the Divine plan of the ages, as it marks out the plan in a mathematical and symbolic manner. It first shows us the world that was before the flood, and then leads us up through the Patriarchal age, to the giving of the law, and the start of the Jewish age, as marked by the granite plug. Just as the law blocked the way to true salvation, so did this plug. The passage as it moves upward from that point, then shows the plan of God, to uplift mankind back into perfection. The descending passage, that goes down to the pit, shows the course that mankind, and all human institutions are taking without God. That this passage ends in the pit, symbolizes the destruction of all human institutions, and eventually all individuals, that are in opposition to the kingdom, and Gods plan. This descending passage, marks two important dates, **1874 and 1914**, which shows that the process of removing the present system, has started at time area.

Jewish Age

The Jewish age, was the first step upward for mankind, but none but the Lord was able to keep the law perfectly. By his doing so, he was able to pay the price for the rest of us, and this date is marked by an intersection of a vertical line, which is dropped from the start of the grand gallery, to the floor which represents, **April of the year 33 AD or the crucifixion**. This event opened up the way or the grand gallery, for the purpose of bringing of many sons to glory in the gospel age. The Gospel age is represented, in symbol, by the grand gallery. **In the next age, the rest of the world will only be able to ascend to the level of human perfection, which is represented by the floor of the queens chamber.**

Gospel Age

The gospel age, as represented by the grand gallery, is shown to be drawing rapidly to a close. As we reach the top step, we find the date **1914 AD**, to be again clearly marked, and this confirms that this was an important date. This should not surprise us, since the harvest parallel shows us the same thing. This is not to say that the gospel age has ended, as some have mistakenly concluded, but it does show us that there were some drastic changes, as far as the false church system was concerned. The grand gallery ends, but the way continues into the kings chamber, and at what point the call ends we don't know?

The chronology as presented on these pages, is based on the last measurements of the Edgar's, in which they found that the lengths of some of the passages were measured wrong originally. The symbolic lessons of the passages as presented in the third volume are correct, but the method of arriving at the dates had to be adjusted, as explained in the 1929 pyramid discourse, at the beginning of Edgar's book. The final results of this change, actually show the Divine plan chronology much more clearly.

One year Change in the Flood Again!

The only exception that we have made to Edgar's figures, has to do with the date of the flood. This became a problem, because he used the date for the flood, given in the second volume, page 43. For the reasons which we have given earlier in this work, we had to shift that date by one year. Instead of using the vertical line of the roof passage as marking the date of the flood, we have instead marked off a theoretical vertical line, that passes through the descending passage at 2472.25 BC. This gives us some very interesting results, where this vertical line intersects the platform level. We get 4128.0263 BC, which is very close to **the creation of Adam in 4128.25 BC**. Remember these dates are given in chronological whole numbers.

The Flood and Baptism

Both Adams creation, and his fall, are found to be represented, the one method showing the creation and the other the fall in the garden. This seems to confirm that Pastor Russell, the founder of the Bible Students, was correct in his idea that Adam only spent two years in the garden. To help show that this new flood date is correct, **we have calculated the amount of years from the end of the corrected flood date, to the baptism of Christ, and we get 2471.25, plus 28.75, (Oct 29) = 2500**. This is similar to the calculation in Edgar's book, volume 2, pages 139-140, but from the end of the new flood date instead. This shows that there is a connection between the end the flood and the baptism of the holy spirit. *1 Pet 3:20-21) 20 who once were disobedient, when the patience of God kept waiting in the days of Noah, during the construction of the ark, in which a few, that is, eight persons, were brought safely through {the} water. 21 Corresponding to that, baptism now saves you-- not the removal of dirt from the flesh, but an appeal to God for a good conscience-- through the resurrection of Jesus Christ, (NAU)* This shows us in picture that the anointing of Jesus was the beginning of the anti-typical baptism, which will include not only the church, but also the world!

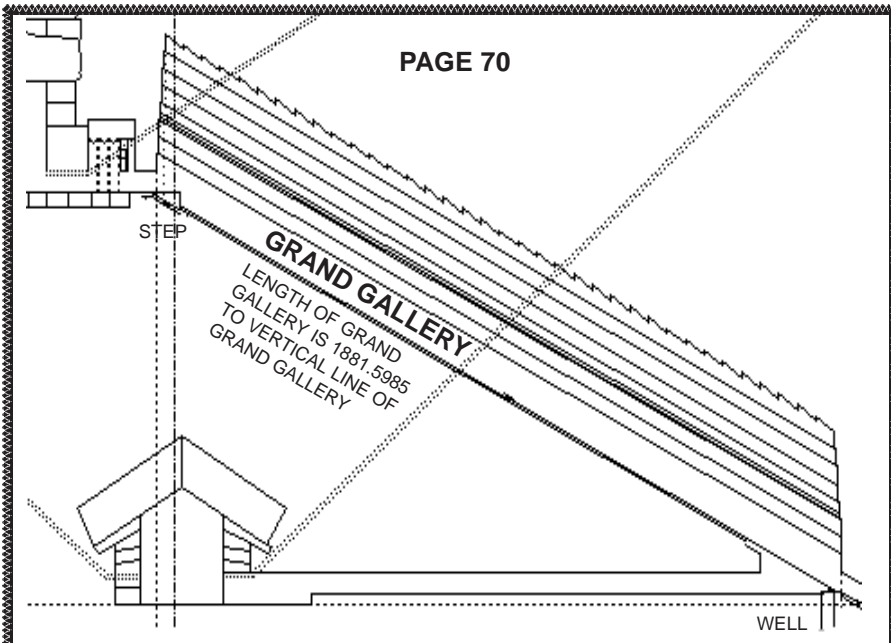

Floor of Queens Chamber

The floor of the queens chamber represents human perfection. This is represented by the dotted horizontal line.

The Birth of Christ

The point where this line intersects the floor of the first ascending passage marks **the birth of Christ in 1.25 BC (Oct 2 BC)**.

The Crucifixion Date

If you drop a vertical line from the beginning of the grand gallery down to the floor of the first ascending passage this intersects the floor at a point which is 33.4553 pyramid inches further up the passage.

This new point is the crucifixion which occurred in April of the yr 33 AD (32.2053) as marked in the pyramid. The actual date was 32.25.

FIRST ASCENDING PASSAGE, WELL AND THE GRAND GALLERY SHOWING THE BIRTH AND CRUCIFIXION OF JESUS

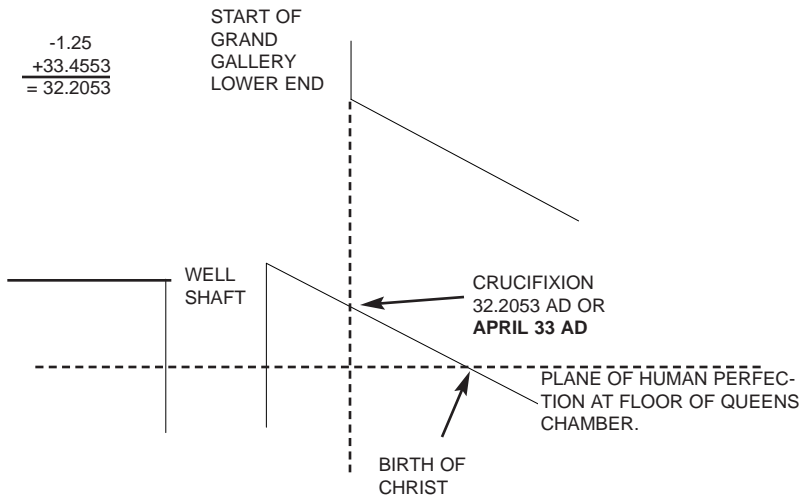

Length of the Grand Gallery

If we measure up the grand gallery and through the step to where it would intersect a vertical line dropped from the upper end of the grand gallery we find that the total length of the grand gallery to this intersect point is **1881.5985 inches or years**.

The Date 1914 Again

If we add this length to the date of the crucifixion at the lower end of the grand gallery we get **Oct 1914 (1913.8038)** at the intersect point. See the diagram at the left.

The Birth of Christ is the Start Point

The birth of Christ 1.25 BC is the starting point that all other dates are measured from on these charts.

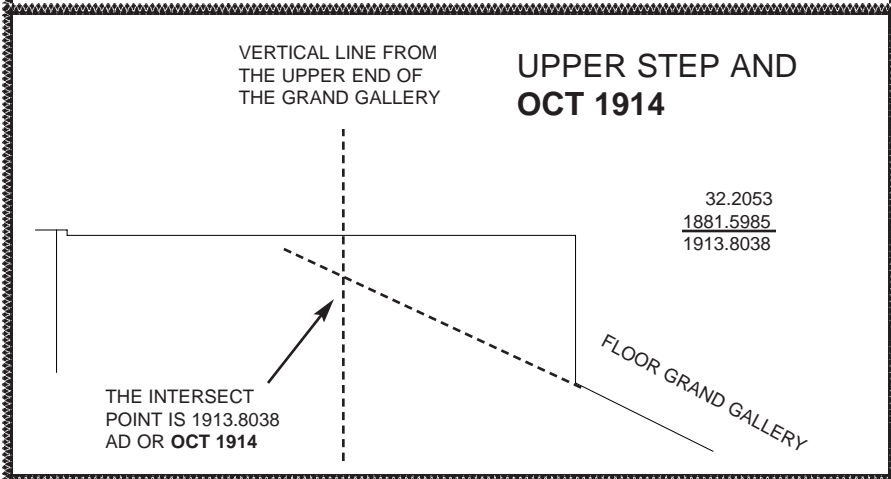

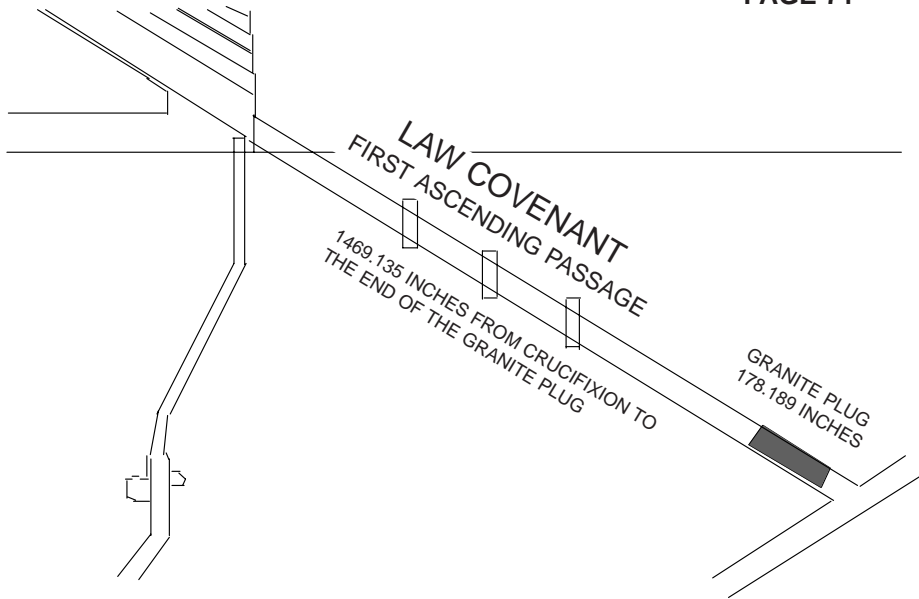

The First Ascending Passage

If we start at the date of the crucifixion and measure back down the descending passage to the lower end of the granite plug we get 1469.135 inches. This date by itself does not reach to the start of the law covenant as we would expect if this passage represents the Jewish age.

Date of Law Covenant

If we add in the length of the granite plug we move another 178.189 py inches or years further back in the stream of time. **This reaches back to 1615.1187 BC. The beginning of the exodus out of Egypt. The giving of the law was 1615.25 BC or Oct 1616 BC.**

This is the same as if you had slid the granite plug down the shaft 1 exact length. It then extends the length of the measurement by 178.189 py inches.

It may be that the reason that the granite plug needs to be slid out of the ascending passage, in order to get the correct date is that the giving of the law was the first step in satisfying justice.

The sliding out of the plug would in symbol show that justice could be taken out of the way by the keeping of the law.

The law provided a way by which justice could be satisfied but as we know only Christ was able to do it.

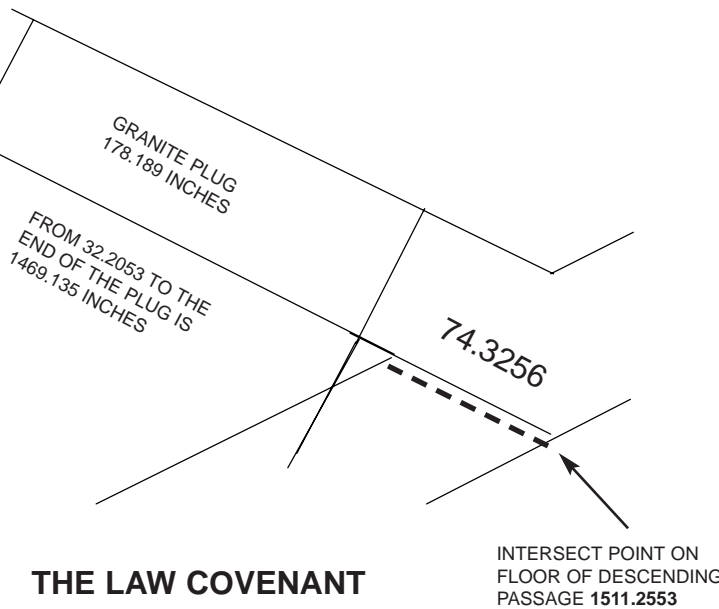

THE LAW COVENANT AND THE GRANITE PLUG

A Key Point on the Floor

In order to continue on with our measurements, up or down the descending passage, we need to establish a date for the intersect point, on the floor. It turns out that the distance from the crucifixion to the floor of the descending passage, is 1543.464 py inches. We therefore get a date for this point on the floor, as **1511.259 BC or Oct 1512 BC.**

We will use this date on the next page, to trace our way back to the entrance of the pyramid and to the creation of Adam. Later we will come back to this same date and point, and from there measure down the passage, to establish the chronology associated with the pit.

The Granite Plug

In the third volume we find this statement on the granite plug *{The only entrance to the "Queen's Chamber," or to the Grand Gallery,} was by way of the "Well," the First Ascending Passage} having been originally impassable by reason of the granite "Plug." Thus the stone "Witness" testifies that by the Law Call or Law Covenant none of the fallen race could reach either life (human life) or immortality (the divine nature). Though the "First Ascending Passage" was a way, yet none could walk in it. So the Law Covenant was a passageway to life; but because of the weakness of the flesh, none could walk in it so as to attain the life offered}.*

The New and Living Way

From this we can see that Christ has now opened, a new and living way for us.

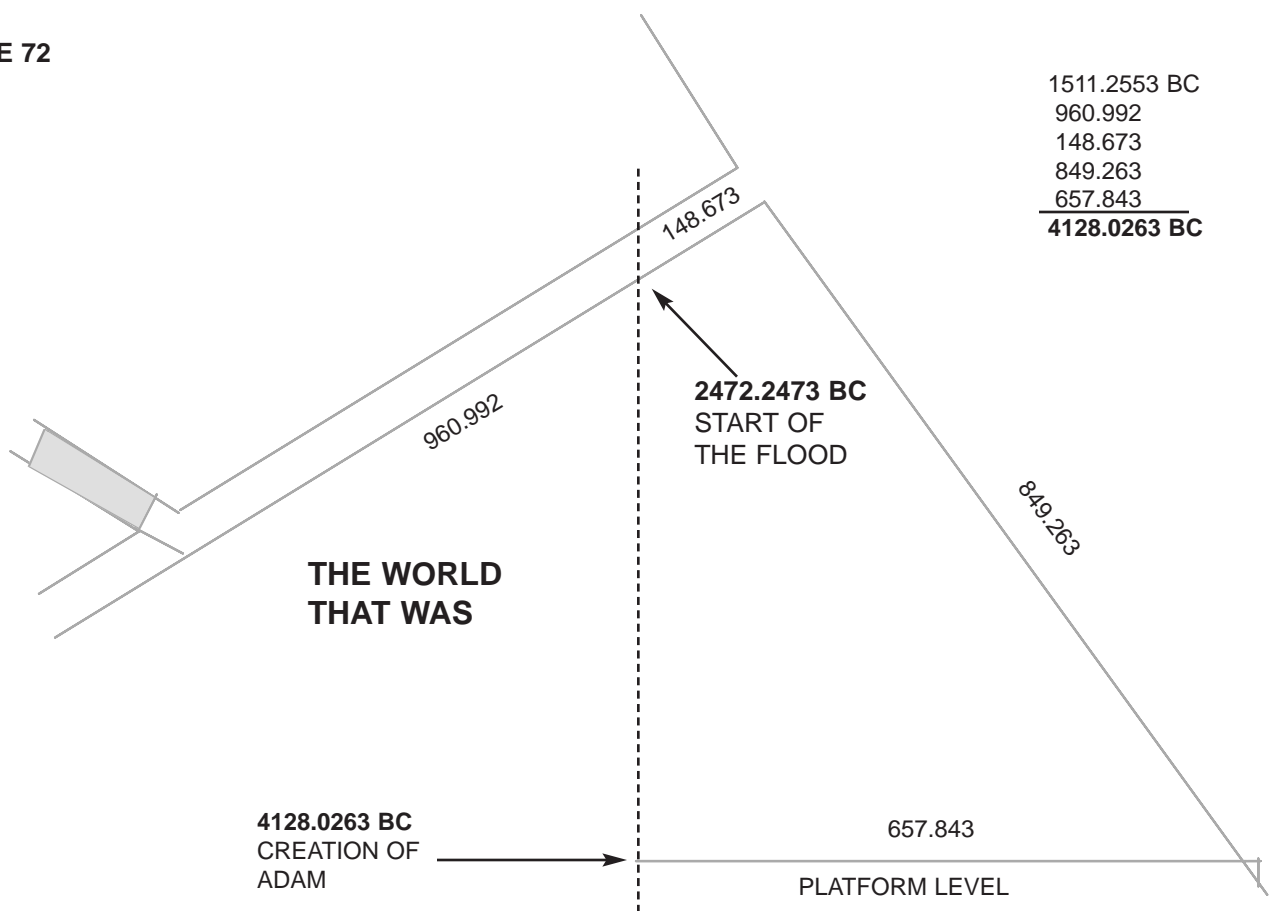

Recalculating from the New Flood Date

The calculations shown above, are different than the ones found in Edgar's book, volume 3, page 95. In Edgar's calculations, he used the vertical line of the roof, beginning as the point that he felt indicated the date of the flood. He there gives the date 2472.25 BC, as the date for the drying up of the flood. As we have already shown earlier in this booklet, this is not correct, because it is 1654 yrs to the start of the flood and not to the end. **The start of the flood should be 2472.25 BC, and the end should be 2471.25 BC.**

It appears that the original idea was correct, but that it needed some adjustment and modification, due to the problem with the flood date. We decided to re-do the calculations, but this time to adjust the vertical flood line, until it was lined up at the start of the correct flood date, instead of at the roof point. As you can see, this came out very closely to the date of the creation of Adam, at the junction of the vertical flood line and the horizontal platform level, that runs horizontally from the top of the small step.

The Creation Date for Adam

These calculations, remember, reach all the way back to the date of the birth of Christ, at the top of the first ascending passage 1.25 BC. The point of intersection with that passage and the descending passage, is 1511.2553 BC. The distance up to the new vertical flood line, is 960.992 py inches. From there to the outer casing stone surface, is 148.673 py inches. Down the

outside of the pyramid, to the platform level, is still 849.263 py inches. From there, over to the vertical flood line, is now 657.843 py inches. **Adding these all up, gives us 4128.0263 BC, or very close to 4128.25 BC, (Oct 4129), which was the creation of Adam.**

Since the roof overhang is used in other calculations, we believe that it also a valid date point, even if it is not the date of the flood. If we drop a vertical line from the roof overhang, its still possible to get the date of the fall of Adam. This is a distance of one inch upward on the descending passage, and is the 1 year we needed to correct for the flood date.

The Date of the Fall of Adam

The distance at the platform level, is shortened .897 inches from its original length. These two figures add up to 1.897 inches. **If we subtract this figure from the date of creation, marked by the pyramid calculations, we get 4128.0263 - 1.897 or 4126.13 BC.**

2 Years in the Garden

This is very close to the actual figure of 4126.25 BC, for the fall in the garden. **The figure of 1.9 inches, is very close to the 2 years that Adam spent in the garden before the fall.**

The creation and the two years spent in the garden, are both confirmed by the vertical lines, dropped from the flood date and the roof overhang down to the platform level.

DESCENDING PASSAGE

PAGE 73

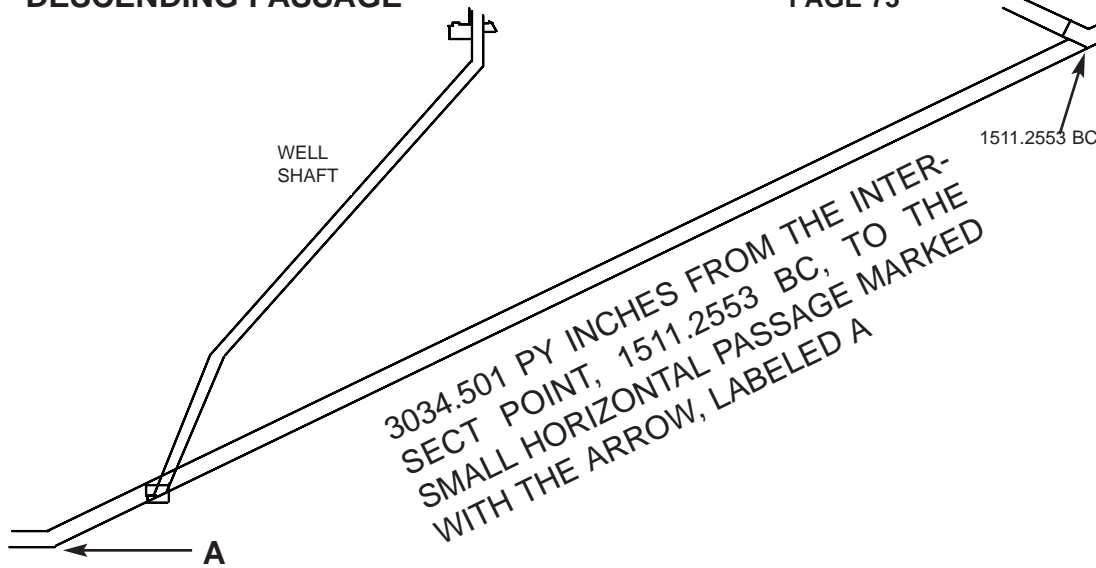

To the Small Horizontal Passage

If we measure downward from the intersect point, 1511.2553 BC, to the start of the small horizontal passage, we get 3034.501 py in. This is to the point marked A in the diagram on the left.

An Intersecting Line = 1914

If we measure on the same angle, down through the stone until we reach the dotted vertical line, that was dropped from the upper end of the grand gallery, we get another 390.871 py inches, at point (F). See the middle and lower diagram. **This gives us 1914.1167 which is slightly long versus 1913.75.**

The Dotted Vertical Line

The vertical dotted line, is the same line that is dropped from the upper end of the grand gallery, through the step, to give us the date 1914. The reason there is some uncertainty on these measurements, is because the end of the passage is not even or square.

THE PIT AND THE SMALL PASSAGE

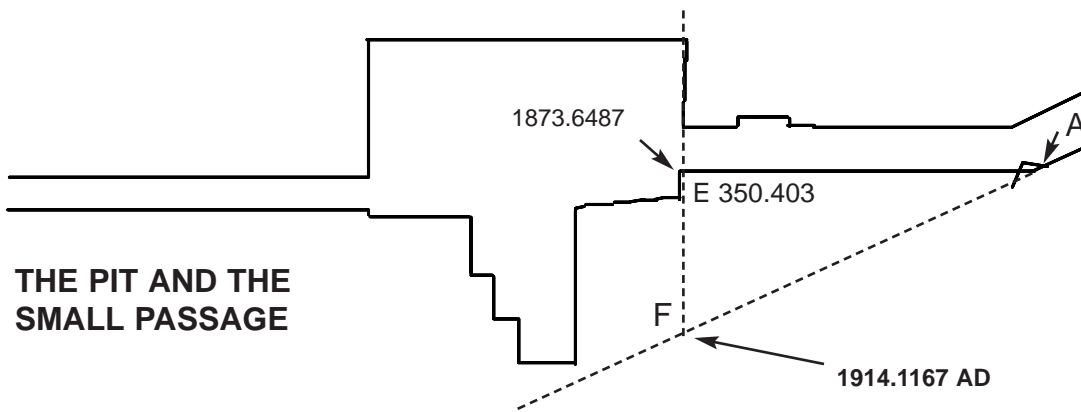

THE INTERSECTION BETWEEN THE DESCENDING PASSAGE AND THE HORIZONTAL

LUTHER WAS SEPARATED FROM PAPACY AT THE DIET OF WORMS APRIL 17, 1521. THE DATE 1520.499 IS JUNE 1521. REPRINT 3574-75

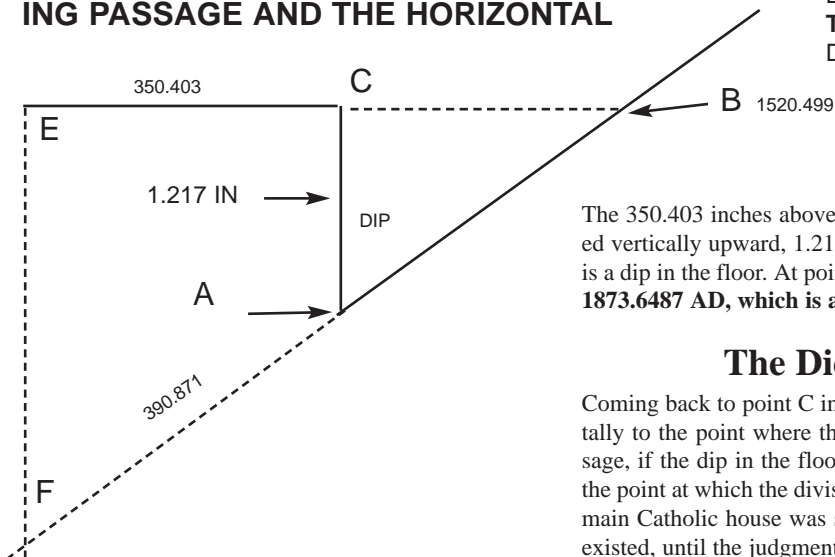

Oct 1874 Again

The 350.403 inches above, are measured horizontally, from point C, which is located vertically upward, 1.217 inches from the end of the passage, at point A. Point A is a dip in the floor. At point E, where this passage intersects the vertical line, we get 1873.6487 AD, which is almost exactly, Oct 1874 AD.

The Diet of Worms in April 1521

Coming back to point C in the diagram above, if we construct a dotted line horizontally to the point where the horizontal passage would intersect the descending passage, if the dip in the floor were not there, (point B), we get 1520.499 AD. This is the point at which the division between Catholicism and Protestantism occurred. The main Catholic house was separated from the reformers, at that time. This condition existed, until the judgment of the rest of the house (1874-1914).

Many Questions Answered.

The material in this booklet, has at least for us, answered many questions that we had when we first started studying the Bible, and we hope that it has done the same for you. For example, we had wondered why the vision of the 4 Cherubs in Ezekiel, were different than the 4 living creatures in Revelation, and the Seraphim of Isaiah. We can now see that this was because each of them, is dealing with a different portion of the chronology, and that each has its own Biblical theme.

We hope that these pages have helped some to a stronger faith in our Lord and in his Plan of the Ages. We think that chronology is very important in this regard, in that it helps us to see that God has been working out his plan, all through the ages. As we have studied these patterns, we have gradually come to see that they not only support the chronology of the Divine plan, but they support the plan itself, by showing God's four attributes, wisdom, justice, love, and power. If your understanding of God's plan does not include these four attributes in a proper balance, you do not have a correct understanding of his plan!

1845 Judgment

Ezekiel's vision represents the 1845 year parallels, and deals with a common topic of judgment, in that the 7 different dates on it have to do with different judgment periods. The final judgment on this chart, shows us that after mankind is restored back to perfection, they will be granted a final test. The crucifixion date, is also found on this chart, which tells us that God's love provided the ransom, in order to satisfy justice.

They Will Stand on Their Own

The final date on that pattern, is the test of the little season, found in Rev 20:7-10. **At that point, everything will have come full circle, and those who have regained life, will be granted a new trial, to prove their loyalty. Instead of being born into sin and death, they will all have a chance to stand on their own merit.** *Jer 31:29-30) 29 "In those days they will not say again, "The fathers have eaten sour grapes, and the children's teeth are set on edge." 30 "But everyone will die for his own iniquity; each man who eats the sour grapes, his teeth will be set on edge. (NAU)*

Haven't we all said at one time or another that we wished we had another chance? At that time God is going to grant that wish for everyone and he is going to give us every possible chance to pass the test by restoring us all to perfection first. With the experience that we have had in this life with sin and death most should pass. If they don't it will be their own fault and not the fault of anyone else.

1260, 2520 Dominion

Adam was created Lord of everything that he saw in the garden, but he lost that in the fall. **The 1260 and 2520 pattern, seems to contrast man and God, by showing us what happens when man rules over creation, in his fallen state.** We see nothing but misery and oppression of others, as well as of the animal creation. In the end, we see that God sends Christ to rule over the creation and to restore it back to its original perfect state. Only when mankind has been restored to a perfect moral condition, will he will then be able to rule over creation again, without harming or destroying it.

A 19 Year Solution?

As we mentioned in a couple of other places in this booklet, there is a question on the 607 BC date. Secular history places the carrying away to Babylon in 587 BC instead. After having examined this subject in depth, it appears that it is hard to get around this problem. The first solution that we advocated for this, in earlier edition of the book, did not stand the test of time.

We think we have found a solution to this, that would keep all of the chronology as found in the volumes functionally intact. The only difference would be that the 2520 and the 70 year desolation, would start at the conquering of Israel by Nebuchadnezzar, rather than at the destruction of Jerusalem? **We would shift the 19 years removed from there and reallocate it to Joshua. The difference would come about, because the volumes count him as a judge, and the scriptures do not talk about judges, until after he died!**

As near as we can tell at this time, this solution does not cause any problems that can't be explained. This also has the added benefit in regard to these charts, in that one of the 2520 circles, now intersects the destruction of the 10 tribes, where it did not before! Because of this and a couple of other possible changes, we now get 10 dates on that chart. That is interesting, since ten is a perfect earthly number, and that chart deals with civil power, and who has the right to rule on earth.

2500, Love, and the Jubilee

Isaiah's vision of the Seraphim, represents the 2500 year chronology and restitution, that is going to come to world. Through love, God supplied Christ, who will restore all of mankind from the prison house of death. Just as in the jubilee type, we see that every who is a slave to sin, will be released from that bondage.

A question Yet

We still have a question about the third date on the Jubilee chart, since that time area is uncertain. It could be Judge Jephthah and his daughter, who is a type of Christ and the

church. Jephthah made an oath, to offer whatever came out of the door of his house, to meet him as a burnt offering, if only he could win the battle with the children of Ammon, that he was going into. Unfortunately for him, it was his daughter that came out of the house to meet him. Many think that this offer was to death, but it was not, because a human sacrifice would have been against the law. It was most likely service to the Lord, for the rest of her life, similar to Samuel. For that reason they are a good picture of the church.

Jephthah, would represent a change from the thought as given in the original reprint article, where Jair was on the corner date. While there seems to be no way to prove this with certainty, it seems that we need to make this change, based on the statement of Judges 11:26, where it tells us that it was 300 years from the dividing of the land, to the oppression of the Philistines (Judges 10:8).

The Answer Needs to be a Type of Christ

Regardless of who is picked here, he needs to be a type of Christ, since he is born on the opposite corner of the tabernacle from the birth of Christ. (Jair is the only other possibility, and he would be a good choice also, since his name means enlightener!

2971 *Ya'iyir (yaw-ere')*; from 215; enlightener; *Jair, the name of four Israelites: KJV-- Jair. 215 'owr (ore); a primitive root; to be (causative, make) luminous (literally and metaphorically): KJV-- X break of day, glorious, kindle, (be, en-, give, show) light (-en, -ened), set on fire, shine)?*

A prayer Answered

At one time, someone asked if anything extra would be shown, by placing the three different patterns together into one chart. That turned out to be an interesting experiment. We noticed that there were two sets of dates generated on the chart, that point directly to Christ. On the left half of the chart, we had a gap of 30 and 33.5 years. The same was true on the right half of the pattern, with a 30 and 33.5 year gap. The three different patterns together, show Gods plan and its great wisdom. It also shows us, that all 4 attributes of God work together, in perfect balance. **Just as Hab 3:2 had asked, God both literally and symbolically showed his plan, through the midst of the years.**

We now know that his prayer was answered and the answer is the Divine Plan and the chronology associated with it. The patterns show key aspects of the plan (judgment, dominion, restitution, and power). Mankind will be shown mercy, and delivered out of wrath, by the end of the millennium.

Patterns of Chronology and the Plan

These repeating patterns, show that the divine plan as we know it, is correct, and that God has had complete control

over the course of history and his plan from the beginning! .

A Power Struggle

The 2520 and the 1260 vision of the throne scene in Rev, is pointing to God and Christ, who are to rule over the world in the next age. The chronology associated with this vision, marks off the time that the false system was to be allowed to exist, before they were to be disposed of, with their false claims. All of Rev gives us information about this struggle, and the eventual victory.

A Time of Restoration

The temple scene in Isaiah, while showing judgment, asks the question how long? This implies a time for punishment and then a time for restoration. The 2500 associated with this vision, points us to 1874, and to the 1000 year day of restitution, that started then, (Acts 3:19-21). This day will not only restore Israel, but it will also adopt the world of mankind into the salvation, and restore them back to the life that Adam lost!

Overwhelming Problems Now

The kingdom is waiting for the completion of the church, and then it will restore all who are willing. The time of trouble that we are in now, seems to confirm that we are close, because there seems to be no solution for the problems everyone is having. We are entering into a historical time, where almost any country can own weapons of mass destruction, and no one seems to be able to stop the spread of them. Even without artificial plagues, made for war, it seems that nature itself has turned against us, in that we find that the medicine that we trusted to cure many exotic diseases, no longer works because of new super bugs.

Almost all countries are experiencing financial problems, that threaten the well being of their citizens. **Israel seems to be in the news almost every day, with attempts at peace, that does not seem to ever actually come.** These problems will probably not be solved, until the kingdom comes in to fix them. When that will be, no man knows for sure, but only God!

We Pray for thy Kingdom

We can only look at the patterns before us, and know for a certainty that all these bad things will come to an end, when the blessings of the kingdom come. We pray that the new heavens and the new earth are not that far off.

(Rev 21:4-5) 4 "And God will wipe away every tear from their eyes; there shall be no more death, nor sorrow, nor crying. There shall be no more pain, for the former things have passed away."

5 Then He who sat on the throne said, "Behold, I make all things new." And He said to me, "Write, for these words are true and faithful."

A SUPPLEMENT SHOWING HOW THE 1845 YEAR REPEATING PATTERN OF CIRCLES WAS CONSTRUCTED

The next few pages are an optional supplement, in which we will explain how the 1845 year chart is constructed. We have decided to include this section, for two reasons. First, many brethren would like to have a more complete explanation, of the theory behind these charts. Second, we would like to make it plain that we constructed these charts from Biblical dates and concepts. In other words, we didn't invent the pattern that you see, in order to satisfy some idea that we had.

The Time From the Midst of the Years, to the Crucifixion, is Unchangeable

We originally discovered the 1845 year pattern by accident, and at first did not have the complete pattern. It took several years and some false starts, before we were able to reach the completed patterns, of not only the 1845 year chart, but the other two as well. We worked with a lot with trial and error at first, in trying to determine what the exact size of the circles had to be, in order for them to work. Eventually we arrived at a good enough understanding of the principles behind this chart, that we suddenly realized that the size of the circle, from the center point of the 7000 years to the crucifixion was a fixed number, that could not be changed, namely 626.25 BC to 32.25 AD or 658.5 years. After that, all the rest of it fell into place, with the exception the minor adjustment to the flood date, as explained earlier in this book.

These Numbers Don't Lie

While it's true to a certain extent, as some claim, that you can prove anything with numbers, this is only true if you stay with relatively simple concepts, like single dates. When we get into a larger framework, like the chronology as found in the volumes, it then becomes less likely that it is being manipulated. Even at that point, it could be argued by critics, that the pattern is being forced. But when we begin to get a symmetrical pattern, like what you see in the expanded charts, it becomes much harder to say that they were an accident or manipulated. That is why we can make the statement, that these charts confirm our chronology and the Divine Plan.

The Circles were Constructed From Biblical Dates, not Assumptions

Some might feel that we have made assumptions regarding the size of the circles, so as to make the pattern come out as we wish. We plan to show in the following pages, that this is not the case. If we can show that we did not construct these circles from assumptions, but from well established historical dates, it will then have become evident that these charts are not a construction of man, but of God! We are going to cover only the 1845 chart at this time, because of limited time and space. Also the 1260 and 2520 year chart

,is of a much more complicated pattern, and we don't wish to lose anyone with its complexity, if we can help it.

The only thing we wish to say about the other charts, at this time is that they also fit into the same pattern as the 1845 chart, since they also are symmetrical about the middle point of the 7000 years, mentioned in Hab 3:2.

A What if Exercise?

Before we continue on with how the 1845 year chart is constructed, lets imagine that you have been given the job of constructing, three sets of circles, that are of different sizes from each other, and you had to make each set symmetrical about the center of a 7000 year time period. You would probably say that would be an easy job. If we told you that you had to use the 1845, 1260, 2520, and 2500 year chronology from the volumes, for the sizes of circles you could still possibly accomplish the task. But if you then had to make each individual set of circles, intersect 7 important historical Biblical dates (a total of 21 dates),the job would have become impossible. In the case of the 1260, 2520, it may be 10 dates!

To make it more difficult, lets throw in the necessity that one of these patterns needs to be generated from the posts around the wilderness tabernacle, by using a symbolic 25 inch cubit. So that no one thinks that this was an accident, you also need to have this 25 inch cubit apply to any other place in the Bible, where God has supplied the dimensions. Don't forget, that this has to also work with the 25 inch cubit, in the great pyramid!

After you complete the 3 individual charts, you then need to be able to put them together, into one chart, so that the overlapping circles, form the 30, and 33.5 year gaps.

Each of the three Charts Has Its Own Biblical Theme

If we make the requirement, that each of the three sets of 7 dates, needs to cover a different Biblical theme, we again add to the challenge.

Judgment

The 1845 year chart, shows first the judgment of Adam, then man in the flood, then Israel at the first advent, the judgment of the nominal, and finally all mankind.

Right of Dominion

The 1260 and 2520 year charts, shows dominion or right to rule,from the time of Adam and his loss in the garden, up through Israel's loss of its kingdom, and then the false reign of the nominal, and its loss, and finally the second presence, and he whose right it is to rule, (Christ).

The Jubilee Shows Love

The 2500 of course shows the fall in the garden, the sending of the savior who was to reverse this fall and then finally his second coming and the restoration of all that was lost.

The 3 Patterns Need to Match 3 Separate Visions

We will also throw in the requirement, that the 1845 year pattern, should show in a graphical sense Ezekiel's vision. The 1260 and the 2520 year charts should show John's vision, in Revelation and the 2500 year Jubilee, should match Isaiah's vision of the Seraphim. Is it a coincidence, that the 1845 year parallels and Ezekiel's vision, both show judgment (chapter 9 of Ez. especially)?

The 1260 and 2520 and the right to rule are also important themes in Revelation. The false nominal system is first shown gaining and then losing power. God and his son, are then shown taking their place, as rightful rulers in the kingdom.

The 2500 year chart shows restitution, through the ransom, and we see this in Isaiah 6:, when Isaiah is cleansed by the coals of fire on his lips.

But all this coincidence would be for naught, if we had merely had invented the circular patterns and had been extremely clever in making them match the bible Chronology.

A Step by Step Construction

To demonstrate the truthfulness and reality of these concepts we are going to construct the 1845 yr circles one by one, and show that they can not be changed from the size that they are, without destroying the pattern or missing some of the 7 key dates. To change the circles in size, by even one year, will make the pattern fail to satisfy the above requirements!

The Plan of God is 7000 Years Long

To start the construction of this chart, we first need to believe in the concept, that the plan of God from the fall in the garden to the complete restoration in the kingdom, is 7 x 1000 year days, or 7000 years long.

A Simple Rule of Symmetry

The only assumption that we will need to make, is the rule that if a circle exists on one side of the midpoint, then we can construct an exact corresponding symmetrical circle on the other side. This concept will be seen to be the same, and common to all three patterns.

Read the Dates Carefully, See Page 2

One word of caution, we need to mention before we start, is that we are going to be using mathematically correct dates, and in order to read them correctly you should consult the instructions on page 2 of the charts.

Starting With What We Already Have

We are going to start the construction of the circles, by placing the two 1845 year parallels, as found in the volumes.

The first circle reaches from 1813 BC to 33 AD.

The next circle goes from the crucifixion, in the Spring of 33 AD, up to the end of the parallel, in the Spring of 1878 AD.

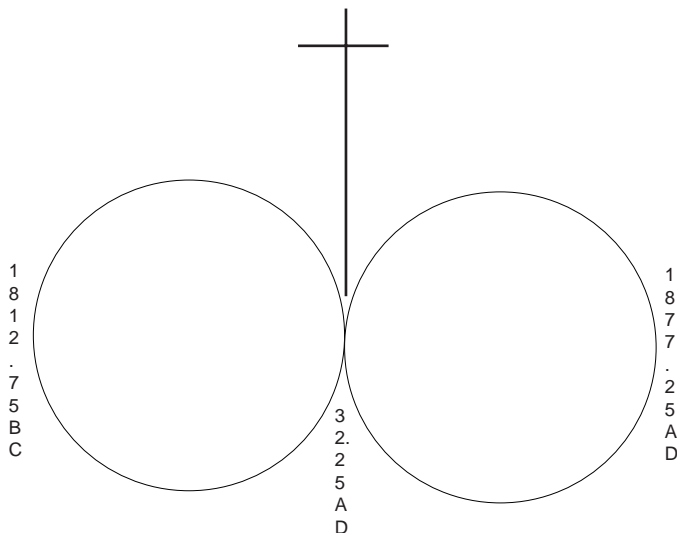

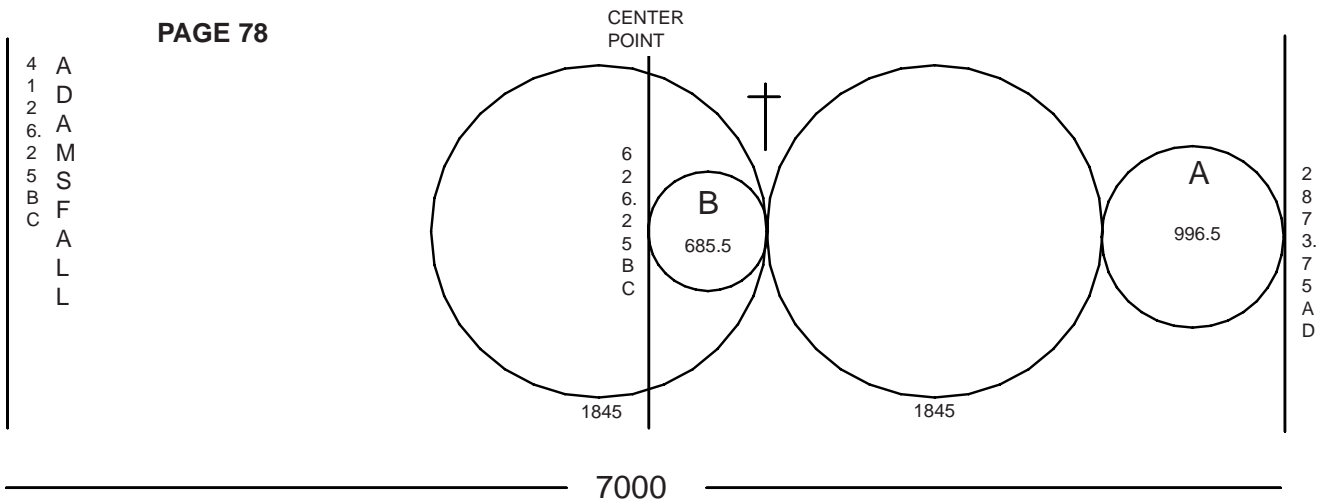

More Historically Defined Dates

In the above section, we have drawn lines at the beginning, end, and the center point of the 7000 years, of Gods plan. The distance from the end of the 1845 year parallel, 1877.25 AD, until the end of the 7000 years, 2873.75 AD, equals 996.5 years. We have drawn that circle, labeled A, in place, $(2873.75 - 1877.25 = 996.5)$. From the center point until the crucifixion, turns out to measure exactly 658.5 years, and we also have placed that circle, labeled B, $(626.25 \text{ BC} + 32.25 \text{ AD} = 658.5)$. We could draw in the mirror image, of the four circles, at this time on the other side of the center point, but we don't want to do that, until later, in order to keep things sim-

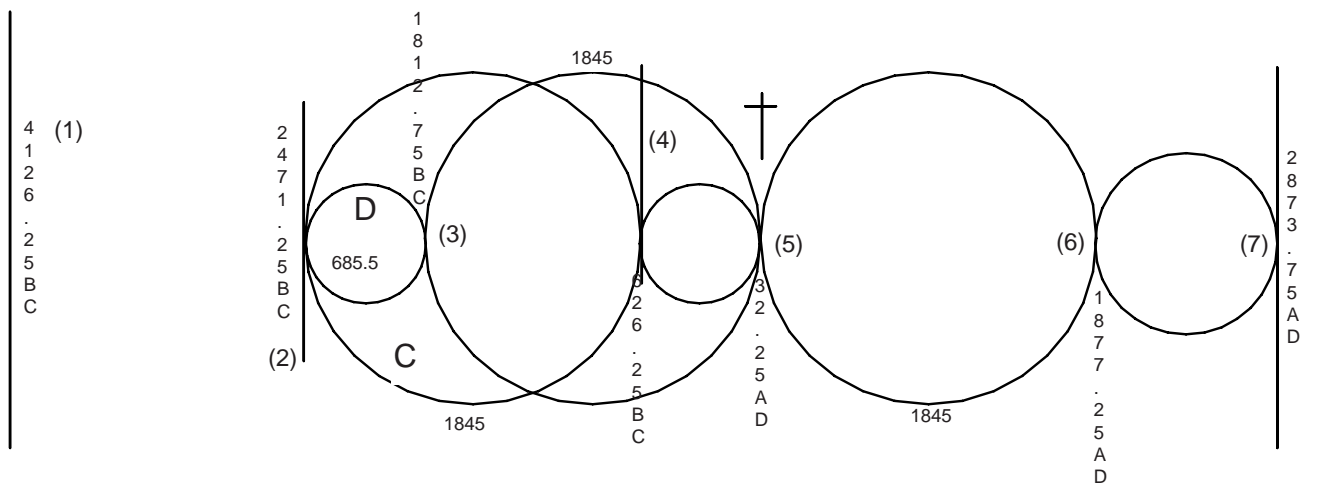

Placing the Last Circles, that Are Historically Defined

If we take the corrected date of the end of flood (2), as explained earlier in this booklet, and subtract the death of Jacob (3), from it, we find out that the distance between these two dates, is also 658.5 years, $(2471.25 \text{ BC} - 1812.75 \text{ BC} = 658.5)$. The total number of years from the flood date (2) up to the center point of the years (4) also turns out to be 1845 years $(2471.25 - 626.25 = 1845)$. We have numbered and drawn in both of these circles, labeled C and D.

Symmetrical About the Center Point

At this point, we can't go any further on these charts, unless we use the concept of making the circles symmetrical about the center point. In other words, what exists on one side, should have a symmetrical mirror image on the other side. Before we complete the chart on the next page, please note that all 7 dates are on the chart at this point in its construction.

The Seven Dates Fix the Pattern in History

We wish to emphasize, that those seven dates, are what define and limit the chart to what you will see, when we are done. With those dates in place, its impossible to change the size of the circles from what they are! Therefore, its impossible to make a chart with just any size circles, as some might claim.

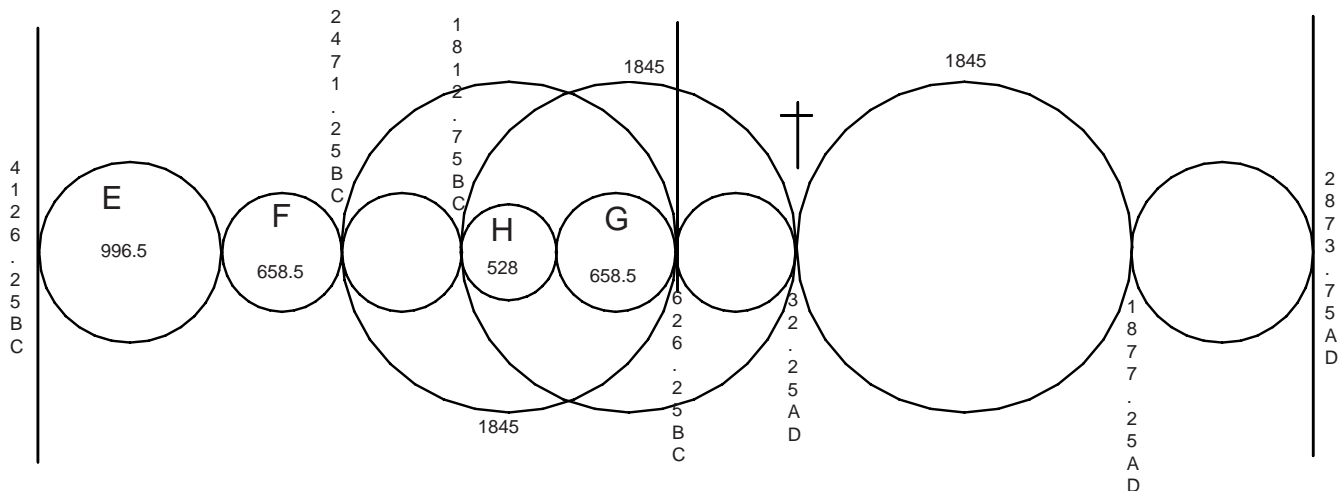

Mirror Imaging Some of the Circles

We first take the 996.5 year circle on the right, and place a mirror image of it on the left, labeled E. The distance between the end of the 996.5 year circle we just placed, and the end of the flood, is also exactly 658.5 years, labeled F, $(4126.25 - 996.5 = 3129.75 \text{ BC})$ $(3129.75 - 2471.25 = 658.5)$. If we take the 658.5 year circle that runs from the center point of the years to the crucifixion and place its mirror image, labeled G, we get the diagram above. The 528 circle, labeled H, is what is left over, out of the 1845 yr circle, if you take away two 658.5 circles. The new circles that we have just drawn in have the size typed into them, and a letter label on them.

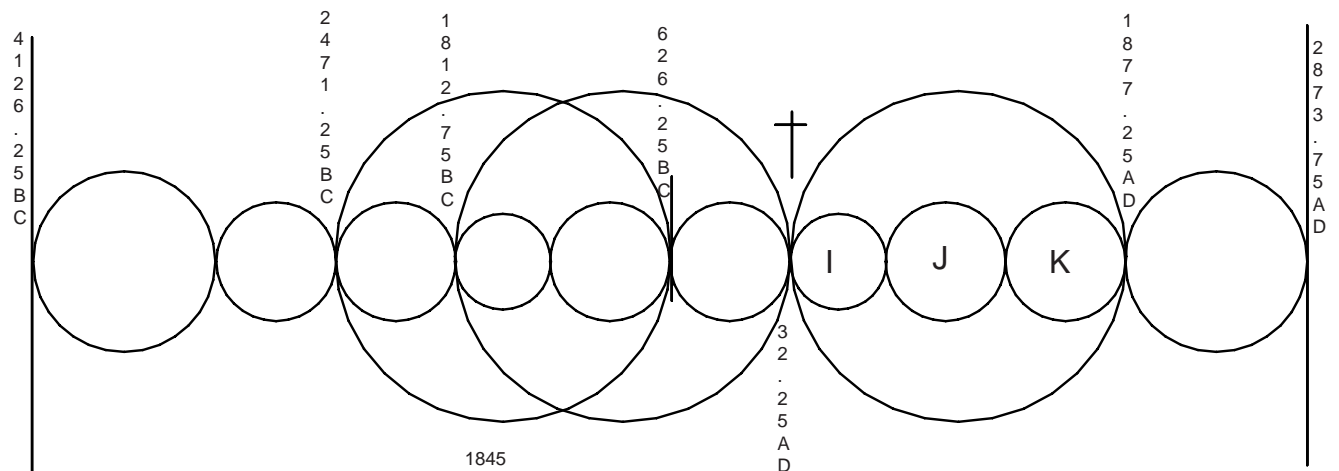

Completing the Mirror Imaging and the Pattern

In order to complete the three small missing circles on the right side we will place them by again creating a mirror image of the three corresponding circles on the left side. The new circles are labeled, I, J and k. After doing this, we now have all the circles, except for three of the 1845 year circles. These can be gotten in two different ways. First of all, if we placed the mirror images of the three existing 1845 year circles, we would then have all of them. If we didn't want to do this, we could measure the existing small circles and we would find that any three adjacent circles, not counting the two end ones of 996.5, would add up to 1845 years, $(658.5 + 658.5 + 528 = 1845)$. If we draw all the circles in, we have the diagram of the 1845 year pattern. We have not made any assumptions, except the idea that everything should be symmetrical, or mirrored about the center point of a 7000 year time period. As you should now be able to see, this pattern has been determined by the 7 Biblical dates.

WHAT WOULD HAPPEN TO OUR CHRONOLOGY IF WE CHANGED THE COUNT OF THE YEARS

607 BC or 586 BC?

Since there is an open question, as to whether the civil historians, or our Bible Student chronology is correct, in regard to the 607 BC date, we are going to show in the next section, what would happen, to not only the patterns found in this book, but also the chronology in the volumes, if we were to accept the historians ideas in regard to the desolation. (*Since we wrote this section one other possibility using a shift of 19 years within the same cycle, has come to light. The proposed change, would not have any of the problems, that we will described below!*) We are still going to keep this section, because it teaches valuable lessons about the patterns, regarding taking time out or putting time back into them, and how they would be easily destroyed, if this is not done properly.

We Would Lose 1874

One of the problems that we would have, is that the seventh day or 6000 years from the fall of Adam, would not occur until 1893.75 AD? This would definitely cause a problem with the 40 year harvest, as well as the harvest parallel.

The 1845 year Harvest Parallels Would be Destroyed

The parallels would not overlap 1873.75, or even the new seventh day date 1893.75, by 3.5 years anymore. This happens because the parallels would no longer be 1845 years, but only 1825 years long. This definitely would be a major problem, since we would not come close to reaching the beginning of the seventh day with the parallels.

The 2520 Years Would Not End in 1914 Anymore

The 2520 years of Daniel, would not end in 1913.75 anymore, since we would have 20 years left to go at that time. The resulting date 1933.75, doesn't even come close to being equivalent historically to 1913.75. Nothing dramatic happened in 1934.

The 2500 Year Jubilee Would be Disrupted

The Jubilee would also become a victim of this situation, in that the 2500 would not end in 1873.75, but in 1893.75. We do get a little bit of plus here, in that the new end for the 6000 years would end there, but otherwise that date does not square with anything else.

We Would Lose the Interpretation of the 2300 Days of Daniel

The seventy weeks of Daniel would still work, but the 2300 days as regards the cleansing of the sanctuary. If we were to include the extra literal application of the 2300 days to the restoration of Jerusalem found in this work (334BC-1967AD) we again would lose an interesting feature.

Great Pyramid Would Not Work

The great pyramid would also become a victim in that it would no longer have the correct passage lengths to match up with the new numbers. The great pyramid matches exactly with our original chronology so that by itself should tell us that we have a problem with the other method. **It would be a little bit difficult to take a saw and remove 19-20" of stone and then be able to put the pyramid back together again so that no one would notice!**

It Would Destroy All of the Repeating Patterns in this Book

Besides all of the above problems, things only get worse, if we were to include the repeating patterns, that are found in this booklet. We are going to demonstrate on the next few pages, that if we lose the 20 years, these patterns will not work either.

It has been suggested that perhaps we could take the 20 years out of the place where the civil historians say that they should be removed from, but then put them back in at another location. That is a tempting solution that seems to work, until we look a little closer. The problem that we would run into, at least in regards to the repeating patterns, is that any attempt to place the 20 years back into another location, very far removed from the original placement, would change the length of one of the other circles. *Note: This is the change that we found possible, after this was written, but it is a special case, in which 19 years goes back within the same circle of years! See earlier in this book for an explanation of how this might work!*

That and other problems, seem to show that these patterns are no accident as they are originally constructed, and that they were planned and formed by the Heavenly Father, as he carries out his plan to restore mankind back to the life that they had lost in the garden.

Please look at the next few pages very carefully, and you will see that its not possible, to change anything by as much as a year without disrupting not only the original chronology, but also all the patterns in this booklet! *Note again that this is possible, but only if its put back into the same chronological wheel!*

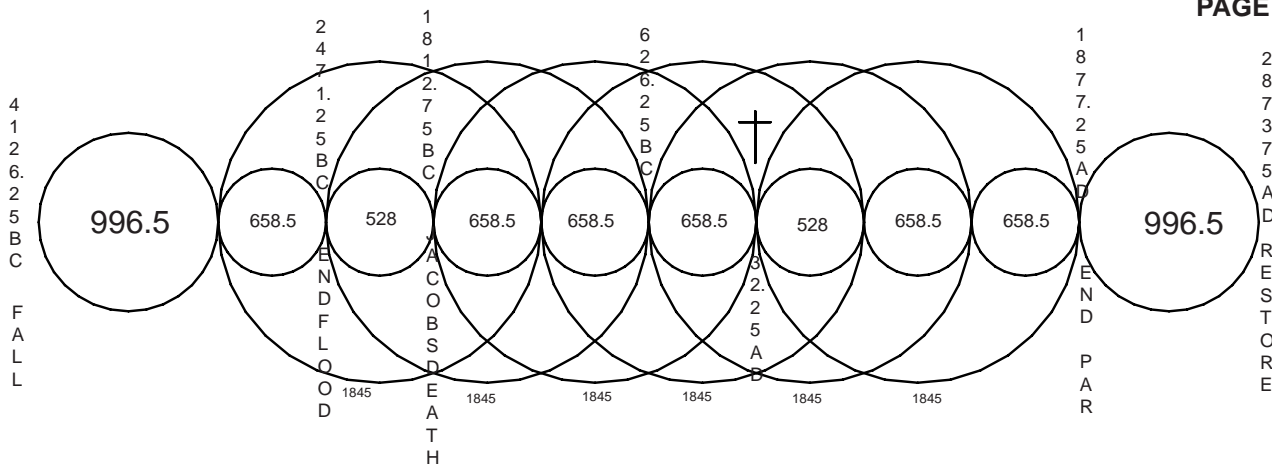

PATTERN PROVING 1845 YR CHRONOLOGY

**PATTERN WITH 20 YEARS MISSING
FAILED ATTEMPT**

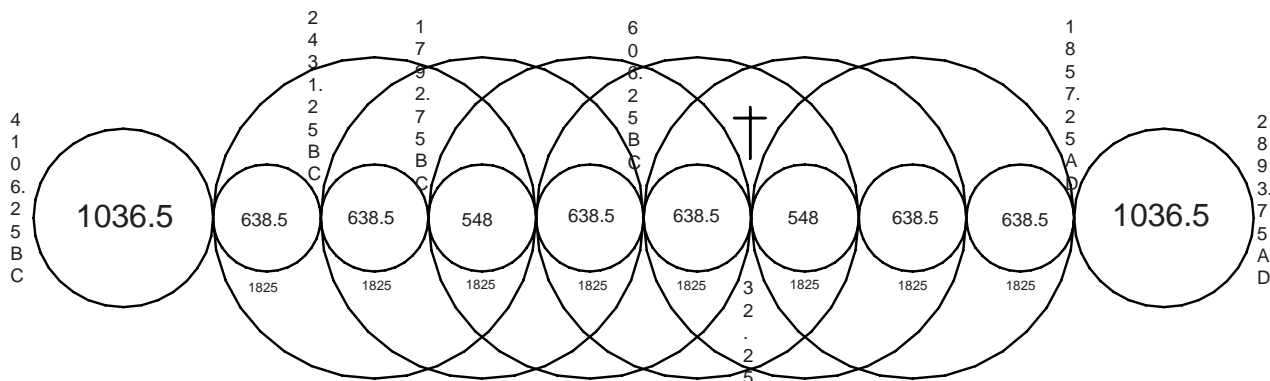

**An Attempt to Take 20 years Out
Without Putting it Back!**

The top drawing, is the pattern that was constructed from the original 1845 year parallels. To help show that it is not correct to change the chronology, we have attempted to construct a chart similar to the 1845 pattern, but with 20 years missing at the time of the desolation. Please remember that we do not think that the following examples are correct, but we intend to construct them according to a couple of different methods, and then we are going to point out what is wrong with the end results.

The lower diagram of the two above, is one of the possible ways to attempt to do this. In this example, we are going to construct the chart with the thought that we need to keep all the large circles the same size, just as they are in the original 1845 year chart. One difference that we find, is that instead of the 1845 yr circles we now would now have 1825 year circles, because of the 20 years that was removed from the area of 607 BC.

Flood Circle is Now Missed

The first major problem that we find is, that if we do this, the date of the flood is no longer intersected by a circle! The orig-

inal 7 dates were the method by which the original chart and pattern were determined, and in this example, because of the loss of the flood date, we would no longer have a way to show how we got the pattern! We could only say that we know how to construct it, because we saw the pattern of the original 1845 year chart, and this would not acceptable.

**The 1845 Year Parallel Does Nor Match
the End of 6000 Years Anymore**

Another problem is that the end of the 1845 year parallel, no longer coincides with the end of the 6000 years. For this reason ,the 1845 year parallels,would be destroyed, because there is no 3.5 year overlap into the 7 th day. This 3.5 years, is what used to parallel the 3.5 years, of our Lords ministry!

Size of the Change Doesn't Matter

The destruction of the parallels, occurs regardless of what size change we make, be it 20, 1, or even .1 year. Twenty years just makes the problem more evident. On the next page, we are going to consider one more method of constructing a 1845 chart, with 20 years missing. We will again see that it is not possible to do this, with the perfection of the original. Only the original method will be shown to keep the chronology intact!

In this second attempt at constructing a 1845 chart with the 20 years removed, we have used the 7 important Biblical dates of the original chart, to determine the sizes of the circles, but with the 20 years removed out of the 607 BC area. To begin this process, we first need to take 20 years out of circle F, since this is the area that would be shortened 20 years by the change in the chronology.

changed to 618.5. This is because $1825 - (548 + 658.5) = 618.5$. Again because of symmetry circles K and B need to be changed to match. Since the 1825 parallel ends in 1857.25 in this attempt, the last circle J would have to be 1036.5 and A would need to be the same again because of symmetry. The new end of the 7000 years would be 2893.75.

Symmetry Needs to be Reserved

One other principle of the original chart, that we feel has to be preserved is symmetry. In other words, the circles need to be of equal size on opposite sides of the chart. In order to preserve symmetry, we need to correspondingly shorten circle E, by 20 years also. Under this new system of chronology, the time from Jacob's death to the crucifixion would be only 1825 years. So that the dates in between would add up to 1825 we need to increase the size of circle D by 20 years. $1825 - (638.5 + 638.5) = 548$. Symmetry again requires that we change circle G to 548. Circle C is a fixed historical time period, that can't be changed and because of symmetry, circle H would also stay the same size.

Any Such Change Destroys the Pattern

The conclusion that we should reach from this, is that any change in our chronology, would destroy not only these expanded charts, but much of what we as Bible students believe. The judgment parallels would be gone, along with the end of the Gentile times. The Jubilee cycles would be in trouble, along with the second presence. It might still be claimed that all these features would still exist, but even if that were true, they would have lost much of their supporting evidence. The harmony and the dove tailing of the original chronology, would no longer be there.

If the parallels are to be actually parallel, circle P needs to be changed to 1825 years so that it matches circle M. To do that circle I has to be

Therefore no matter how great the historical evidence appears to be for a 19-20 year change we can only conclude that this evidence must be flawed. **If not, there must be another equal addition of 19-20 years someplace else, that will keep our chronology intact.**

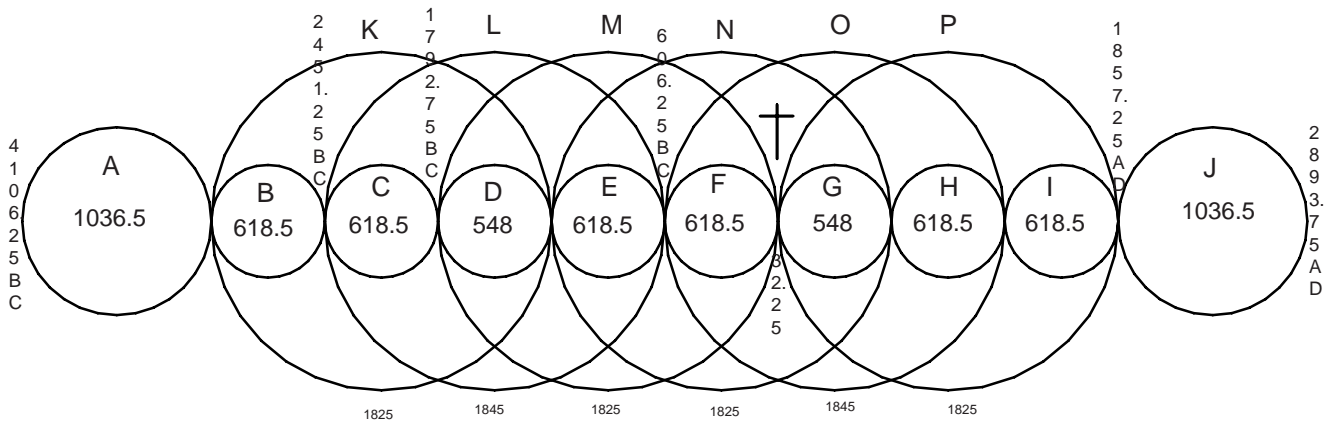

SECOND FAILED ATTEMPT

Parallel is Still Destroyed

This second method of trying to construct a chart with 20 years missing, has gained back the intersect date of the flood that was lost with the first attempt. But we still have the problem, that the parallel is again destroyed in this version, since the ending date is the same as the previous attempt.

Too many different Sized Circles

A new problem that develops with this version, is that we have many different sized circles. For that reason, this pattern is much less convincing than the original 1845, in which all the large circles were the same size. In this version, we have two sizes of large circles, 2 sets of 1845, and 4 sets of 1825.

The original pattern had six 658.5 year circles, and in this version, it has multiplied into 2 sets of 618.5, two 638.5, and two 658.5. The original 1845 year chart, is constructed with only 4 different sized circles! The new attempt on this page, has 7 different size circles. The circles in this version needed to be different sizes, because of the attempt to keep them intersecting

key dates. A chart with less different sized circles, is more convincing, because from a mathematical standpoint, it is statistically more unlikely for this to occur and it can not as easily be claimed that this was an accident, or contrived.

Only the Original is Not Flawed

We can't say that there aren't any other ways, that you could attempt to construct a repeating historical pattern with 20 years cut out of it. But we can say without a doubt, that each such attempt, will have something wrong, when compared to the original. The original chart has the unmistakable perfection of the Heavenly Father. All the other attempts turn out in the end, to have at least one or more things wrong with them. The new versions are like a cheap counterfeit, that appear good from a distance, but upon a closer look, are found to be defective or lacking something. The only conclusion that we can arrive at, is that the total count of years, as found in the second volume, is correct, and any attempt to shorten or lengthen, by any amount, is not correct. On the next page, we will show in more detail, the problems that occur with the original parallel, if you attempt to shorten it.

ORIGINAL CHRONOLOGY

TYPE	ANTI-TYPE	
28.75 AD OCT 29	1873.75 OCT 1874	
FIRST PRESENCE START OF 70 TH WEEK	SECOND PRESENCE END 6000 YRS FROM FALL IN GARDEN--- START OF JUBILEE	3. 5 Y R
32.25 AD APR 33	1877.25 APR 1878	3 6. 5 Y R
JUDGMENT RES- URRECTION	JUDGMENT RES- URRECTION	
28.75 AD OCT 69	1913.75 OCT 1914	
TITUS AND FALL OF JERUSALEM	WW2 AND DESTRUCTION OF KINGS	

4
0

The Original Parallel

In the diagram at the left, we see that the parallels as given by Pastor, form a 40 yr pattern or harvest period, and that this parallels the harvest at the first advent.

At this end of the age, the 1845 years, overlaps the end of the 6000 years from the fall of Adam, by 3.5 years (The same length of time as Christ's ministry). The end of the 6000 yrs marks the beginning of the Jubilee and restitution!

There was a judgment at the first advent, in April 33 AD and there is a judgment at this end of the age, in April 1878 AD. The type is on the left, and the event that parallels it, on the right. The flow of time is from top to bottom.

We see that the start of the historical destruction of Israel's civil power, in Oct 69 AD, has a parallel with the historical outbreak of WW1, in 1914 AD.

Major Problems if Altered

If we were to take 20 years out of the chronology, without putting it back, the diagram at the left is what would result! The position of the end of 6000 years, shifts 20 years forward and the end of the parallel shifts 20 years back. This means that the judgment of the nominal, would now fall 36.5 years before Christ could have possibly could have returned as Lord of the Sabbath, (7th day). The new start of the 7th day, would be 1893.75. This raises the question of who was the Judge, at the end of the new parallel, since Christ couldn't have returned yet!

Another major problem, is that the new position of the 2520, does not match anything important in history, at this end of the age. Its 40 yrs past the end of the new ending of the 6000, but it does not match the 40 years at the first advent anymore. To our knowledge, nothing of any importance happened to Israel in 108.75 AD, (Oct 109)!

FAILURE OF ATTEMPTED CHANGE

28.75 AD OCT 29	NO SECOND PRESENCE NO END 6000 YRS FROM FALL IN GARDEN- -- NO START OF JUBILEE	
32.25 AD APR 33	1877.25 APR 1878	
JUDGMENT RES- URRECTION	END 1825 YRS JUDGMENT? RESURRECTION?	3 6. 5 Y R
28.75 AD OCT 69	1913.75 OCT 1914	
TITUS AND FALL OF JERUSALEM	6000 YRS FROM FALL NEW JUBILEE? NO END OF 2520	3 6. 5 Y R
	1933.75 OCT 1934 NEW END OF 2520	

Another Failed Attempt

The diagram below, is an example of what would happen, if you tried to construct a 1260-2520 pattern, with the 20 years missing from the period of desolation.

In this example, we have kept both the 2520 and 1260 circles the same original size. In order to do this, we had to ignore the historical dates! In this example, we decided that we needed to preserve symmetry about the center point, regardless of anything else we tried!

The 1260 and 2520 are Out of Sync

In this example the 1874, 1914, and the 539 - 1799 dates, no longer intersect circles. Since these dates are after the 587 BC date, they don't follow the shifting pattern of circles caused by the removal of the 20 yrs, but remain where they are historically and do not intersect anything.

The key dates were used to construct the original chart but can't be used in this version, showing its incorrectness!

FAILED ATTEMPT TO CHANGE 2520

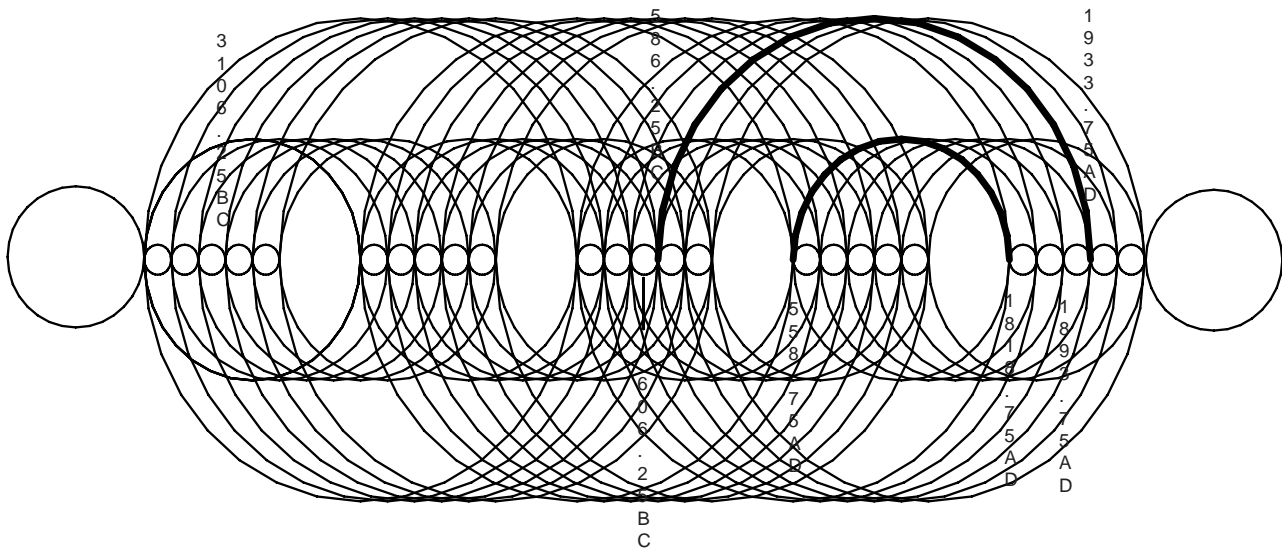

Another Failed Attempt

A second attempt to construct a chart with 20 years missing, but this time trying to use the historical dates in its construction, failed. In this example, the new date 586.25 BC and the old dates 539 -1799 BC would be fixed by history and the new date 1933.75 Ad, would come from the 7 times of Daniel. Another new date that would also be fixed in place, would be the end of the 6000 years after the fall of Adam (This would have become 1893.75 AD.

The 1260 and 2520 are Out of Sync

This attempt failed before we could even make a good start, since any dates that are measured from prior to 586.25 BC were found to be 20 years out of joint, with any date that is measured after that date.

If we wish to increase the size of the circles to make up this

difference, the question becomes, which of the two circles and or how much for each. Lets say that we decided that it had to be the 35 year circle, and we change it to 55. The opposite ends of the 2520 year circles, that make the new 55, also have to be changed, as well as the points on the opposite side of the midpoint, because of symmetry.

The Result is a Final Disruption

This process becomes an impossible task, one change leading to another with the final results being that some of the 1260 year circles, would be 20 years out of joint, with some of the other 1260 and 2520 year circles, again showing that this is wrong! Even a 1 yr change would have the same results, in that the pattern would be disrupted by the lesser amount of 1 yr!

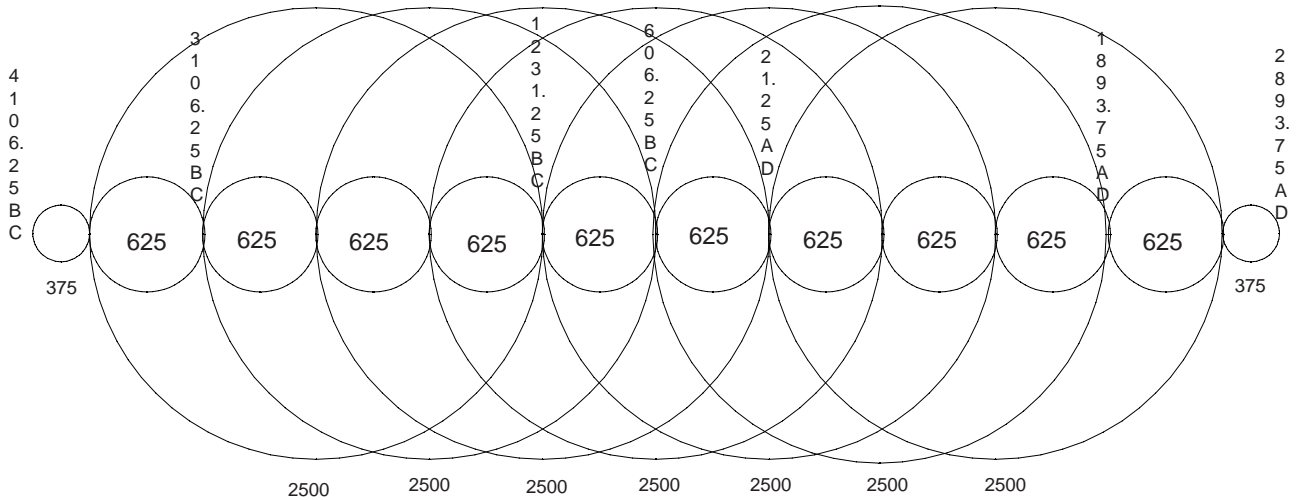

Another Failed Attempt Above

The above chart, is an attempt to construct the Jubilee chart, with the 20 years sliced out of the period of the desolation, but yet keep the circles the same size, (2500). At first glance, it appears that the new version of the Jubilee chart, works just as well as the old one. But don't forget that the original chart intersected 7 important dates, while we find one very important date on this new chart that is not intersected by a circle anymore, the birth of Christ. The circle now intersects 21.25 AD, which we know is not the birth of Christ! Most of the other dates, do not make any historical sense either.

with 20 years missing. This turns out to be an impossible task, because we need to subtract 20 years from the size of the circle, that goes from the center point to the birth of Christ. That in itself is no problem, but symmetry says that we should also change the size of the circle that precedes it, and we can't because it is an historically determined circle.

The Pattern is Again Disrupted

Even if we weren't stopped by this, we would still have the problem that we now have some circles that don't match the rest of the chart. We would have a 605, instead of 625 and we also would have a 2480, instead of a 2500.

Another Failed Attempt Below

The chart below, is a second attempt at construction, using the historical dates to determine the size of the circles, but again

Again only the original chronology works and has the stamp of God's perfection about it, every thing else is a counterfeit!

SECOND FAILED ATTEMPT

